

Manual

LioN-P EtherNet/IP IO-Link Master

0980 ESL 199-121

0980 ESL 199-122

0980 ESL 199-331

0980 ESL 199-332

0980 ESL 398-121

0980 ESL 399-121

0980 ESL 399-121-EEC



Contents

1 About this manual	8
1.1 General information	8
1.2 Explanation of symbols	9
1.2.1 Using danger information	9
1.2.2 Use of general information	9
1.2.3 Version information	10
1.2.4 Designations and Synonyms	11
2 Safety instructions	12
2.1 Intended use	12
2.2 Qualified personnel	13
3 System description	14
3.1 About the LioN/P module series	14
3.2 Special product features	14
3.3 EtherNet/IP product features	15
3.4 I/O port features	16
3.5 Integrated web server	17
3.6 Other features	18
3.7 Product overview	19
4 Assembly and wiring	20
4.1 General information	20
4.2 Outer dimensions	22
4.2.1 Module 0980 ESL 398-121 & ESL 399-121	22

4.2.2 Module 0980 ESL	199-121	23
4.2.3 Module 0980 ESL	199-332	24
4.2.4 Module 0980 ESL	199-122	25
4.2.5 Module 0980 ESL	199-331	26
4.3 Port assignments		27
4.3.1 Ethernet ports		27
4.3.2 Power supply with M12 power L-coded		28
4.3.3 EtherNet/IP and power supply with M12 Hybrid		29
4.3.4 I/O ports as M8 or M12 sockets		30
4.3.4.1 IO-Link Type A		30
4.3.4.2 IO-Link Type B		31

5 Starting operation **33**

5.1 Downloading and installing the EDS file	33
5.2 Reading the MAC addresses	33
5.3 Setting the network parameters	34
5.4 Configuration of the device with RsLogix 5000	36

6 Parameter of the IO-Link Master **41**

6.1 General Device Settings	41
6.1.1 Mapping Mode, Bit 0	42
6.2 Global diagnosis parameter	42
6.3 Failsafe parameter for digital outputs	43
6.4 Surveillance timeout parameter, LioN-P 60	46
6.5 Digital input logic	48
6.6 Digital I/O mode channel B, LioN-P 60	50
6.7 IO-Link port mode parameter (channel A)	52
6.8 IO-Link port extended parameter	55
6.8.1 IO-L Parameter storage	57
6.8.2 IO-L Device Validation	60
6.8.3 Fail Safe Behavior (for outputs only)	62

7 Connections	63
7.1 Exclusive Owner Connections	63
7.2 Listen Only Connections	66
8 Bit assignment	67
8.1 Status data of IO-Link Master (inputs)	67
8.1.1 Status of digital inputs (mapping 1, default)	68
8.1.2 Status of digital inputs (mapping 2)	69
8.1.3 Status of IO-Link communication	70
8.1.4 Status of IO-Link process data validity	70
8.1.5 Status of module diagnostic	71
8.1.6 Status of sensor supply diagnostic	71
8.1.7 Reserved (byte 7)	72
8.1.8 Status of digital output diagnostic	72
8.1.9 Status of module diagnostic	72
8.2 IO-Link Device input data	73
8.2.1 IO-Link data for 4 byte input, assembly 103	74
8.2.2 IO-Link data for 8 byte input, assembly 105	75
8.2.3 IO-Link data for 16 byte input, assembly 107	76
8.2.4 IO-Link data for 32 byte input, assembly 109	77
8.3 IO-Link input & extended IO-Link status data	77
8.3.1 IO-Link 4 byte input & ext. status, assembly 111	79
8.3.2 IO-Link 8 byte input & ext. status, assembly 113	80
8.3.3 IO-Link 16 byte input & ext. status, assembly 115	81
8.3.4 IO-Link 32 byte input & ext. status, assembly 117	82
8.4 IO-Link input & ext. IO-Link status & IO-Link event	83
8.4.1 Event Qualifier	85
8.4.2 Event Code 1 and 2	86
8.4.3 IO-L 4 byte & status & event data, assembly 119	87
8.4.4 IO-L 8 byte & status & event data, assembly 121	89
8.4.5 IO-L 16 byte & status & event data, assembly 123	91

8.4.6 IO-L 32 byte & status & event data, assembly 125	93
8.5 Control data of IO-Link Master (outputs)	95
8.5.1 Control of digital outputs (mapping 1, default) Exclusion: 0980 ESL 3x8-121	96
8.5.2 Control of digital outputs (mapping 2, E2C-comp.) Exclusion: 0980 ESL 3x8-121	97
8.5.3 Control of digital outputs for 0980 ESL 3x8-121 (mapping 1, default)	98
8.5.4 Control of digital outputs for 0980 ESL 3x8-121 (mapping 2)	99
8.5.5 Control of IO-Link COM mode	100
8.5.6 Reserved	100
8.6 Control data of IO-Link Device (outputs)	101
8.6.1 IO-Link Device 4 byte output, assembly 102	101
8.6.2 IO-Link Device 8 byte output, assembly 104	102
8.6.3 IO-Link Device 16 byte output, assembly 106	102
8.6.4 IO-Link Device 32 byte output, assembly 108	103

9 Diagnostics processing **104**

9.1 Error in the system/sensor power supply	104
9.2 Error in auxiliary/actuator power supply	105
9.3 Overload/short-circuit of the I/O port sensor supply outputs	106
9.4 Overload/short circuit of the digital 500 mA outputs	107
9.5 Overload/short circuit of the digital 2.0 A outputs	108
9.6 Overload/short circuit of the type B port aux. power supply	110
9.6.1 For LioN-P 30 devices	110
9.6.2 For LioN-P 60 devices	111
9.7 IO-Link Master error	112
9.7.1 IO-Link C/Q error	112
9.7.2 IO-Link validation error	113
9.8 IO-Link Device diagnostics	114
9.8.1 IO-Link Device error	114
9.8.2 IO-Link Device warning	115

10 EtherNet/IP objects	116
10.1 IO-Link Device parameter object (Class Code 0x80)	117
10.1.1 Read ISDU service (Class Code 0x80)	117
10.1.2 Write ISDU service (Class Code 0x80)	118
10.2 IO-Link failsafe parameter Object (Class-Code 0x81)	119
10.2.1 Set failsafe parameter (Class Code 0x81)	120
10.2.2 Get failsafe parameter (Class Code 0x81)	120
11 The integrated web server	121
11.1 The Status page	122
11.2 The Ports page	124
11.3 The System page	125
11.4 The User page	126
12 Technical data	127
12.1 General	127
12.2 EtherNet/IP protocol	128
12.3 Power supply for the module electronics/sensors	129
12.4 Power supply type B ports (auxiliary supply)	130
12.5 IO-Link Master Ports (X1 – X8, Channel A)	131
12.5.1 Configured as a digital input	131
12.5.2 Configured as a digital output (except 0980 ESL 3x8-121)	132
12.5.3 Configured as an IO-Link port in COM mode	132
12.6 Digital inputs (X1 – X4, type A ports, ch. B)	133
12.7 LioN-P 60: Auxiliary power supply as digital output (X5 – X8, Type B / Ch. B)	134
12.8 LioN-P 30: U_{Aux} (X5 – X8)	135
12.9 Differences between 0980 ESL 3x8-121 and 0980 ESL 3x9-121	136
12.10 LEDs	137

13 Accessories

139

1 About this manual

1.1 General information

Please read the assembly and operating instructions in this manual carefully before starting up the LioN-P modules with the EtherNet/IP interface. Keep the manual where it is accessible to all users.

The texts, figures, diagrams and examples used in this manual are used exclusively to explain how to operate and apply the LioN-P modules with EtherNet/IP interface.

Please contact us if you have any more detailed questions on installing and starting up the devices. We will be happy to help you.

Belden Deutschland GmbH
– Lumberg Automation™ –
Im Gewerbepark 2
D-58579 Schalksmühle
Germany
<https://lumberg-automation-support.belden.com>
www.lumberg-automation.com

Belden Deutschland GmbH – Lumberg Automation™ – reserves the right to make technical changes or changes to this manual at any time without notice.

1.2 Explanation of symbols

1.2.1 Using danger information

Danger information is denoted as follows:



Danger: Means that death, serious physical injury, or substantial damage to property will occur if the required safety measures are not taken.



Warning: Means that death, serious physical injury, or substantial damage to property can occur if the required safety measures are not taken.



Caution: Means that minor physical injury or damage to property can occur if the required safety measures are not taken.

1.2.2 Use of general information

General information is denoted as follows:



Attention: Contains important information on the product, on how to manage the product, or on the respective section of the documentation to which your special attention is being drawn.

1.2.3 Version information

Index	Created	Changed
Version number	Version 1.0	Version 1.1
Date	January 2017	January 2018
Name/department	MJ/R&D	MJ/R&D

Index	Changed	Changed
Version number	Version 1.2	Version 1.3
Date	August 2019	April 2020
Name/department	JGA/R&D	JGA/R&D

Table 1: Overview of revisions to manual

1.2.4 Designations and Synonyms

EEC	Extended Environmental Conditions
LioN-P 30	LioN-P devices with a width of 30 mm
LioN-P 60	LioN-P devices with a width of 60 mm
Type A	IO-Link port specification (Class A)
Type B	IO-Link port specification (Class B)
I/O port	X1 – X8
I/O port pin 4 (C/Q)	Channel A of X1 – X8
I/O port pin 2	Channel B of X1 – X8
U_{Aux}	$U_{Auxiliary}$ ¹
IOL or IO-L	IO-Link
IOL-M	IO-Link Master
IOL-D	IO-Link Device
ISDU	Indexed Service Data Unit
UINT	Unsigned Integer, 16 Bit
USINT	Unsigned Short Integer, 8 Bit
Little Endian ²	Data format of Rockwell Controller, LSB – MSB
Big Endian ²	Data format of IO-Link communication, MSB - LSB
DI	Digital Input
DO	Digital Output

¹ $U_{Auxiliary}$ is the auxiliary power supply to the IO-Link Class B ports X5 – X8 or the actuator power supply to the digital 2.0 A outputs on ports X5 – X8 (LioN-P 60).

² If not other mentioned, the data from IO-Link Device to EtherNet/IP Scanner, or EtherNet/IP Scanner to IO-Link will be transferred by the IO-Link Master without any byte swapping.

2 Safety instructions

2.1 Intended use

The devices described in this manual are decentralized input/output assemblies on a EtherNet/IP network.

We adhere to all safety standards when developing, producing, testing, and documenting our products. When you adhere to the handling specifications and safety instructions described for the configuration, assembly, and correct operation, there should not normally be any risks for people or equipment.

The modules fulfill the requirements of the EMC guidelines (89/336/EEC, 93/68/EEC and 93/44/EEC) and the low voltage guideline (73/23/EEC).

The modules are designed to be used in the industrial sector. The industrial environment is distinguished by the fact that the consumer is not connected directly to the public low voltage network. Additional measures are required for use in residential areas or in business and commercial sectors.



Attention: This equipment may cause radio interference in residential areas. In this case the operator may be requested to carry out appropriate measures.

The proper and safe operation of this product depends on proper transportation, proper storage, assembly, and installation, and careful operation.

A completely assembled device housing is required for the proper operation of the modules. Only connect devices to the modules that fulfill the requirements of EN 61558-2-4 and EN 61558-2-6.

During the configuration, installation, start-up, maintenance, and testing of the devices, adhere to the safety and accident-prevention guidelines for the specific application.

Only install cables and accessories that fulfill the requirements and regulations for safety, electromagnetic compatibility, and, where applicable, telecommunication end devices, as well as the specification information.

Information on which cables and accessories are permitted for the installation can be obtained from Lumberg Automation™ or is contained in this manual.

2.2 Qualified personnel

The configuration, installation, start-up, maintenance, and testing of the devices may only be performed by a qualified electrician who is familiar with the safety standards of the automation technology.

The personnel requirements are based on the requirement profiles described by ZVEI, VDMA, or equivalent organizations.

Only electricians who are familiar with the content of this manual are authorized to install and maintain the devices described. These are persons who

- ▶ based on their technical training, knowledge, and experience, and their knowledge of the pertinent standards, can evaluate the work to be carried out and identify any potential risks or
- ▶ based on working for several years in a related sector, have the same level of knowledge as they would have from the relevant technical training.

Only Belden Deutschland GmbH – Lumberg Automation™ is permitted to make changes to the hardware or software of products that go beyond the scope of this manual.



Warning: Making unqualified changes to the hardware or software, or non-adherence to the warning information contained in this manual, can result in serious personal injury or damage to equipment.

3 System description

3.1 About the LioN/P module series

LioN modules (Lumberg input/output Network) function as the interface in an industrial fieldbus system: They enable a central controller on the management level to communicate with the decentralized sensors and actuators on the field level. The line or ring topologies that can be used to create not only ensure reliable data communication but also significantly reduce the number of cables required and thus also the costs for installation and maintenance. They additionally enable easy, quick extension.

The modules of the LioN-P series have a very sturdy metal housing made of die-cast zinc. The completely cast device housing protects the module electronics from environmental effects and allows the device to be used in a wide temperature range. Despite the sturdy construction, the modules have compact dimensions and a low weight. They are especially suitable for use in machines and installations with a moderate I/O concentration over separate assemblies.

3.2 Special product features

The modules of the LioN-P series have been substantially reduced in size compared with the well-known LioN-R family; the modules have a very rugged metal housing made of die-cast zinc. Housing variants with widths of 30 mm and 60 mm and different connector types are available.

The completely cast device housing protects the module electronics from environmental effects and allows the device to be used in a wide temperature range. Despite the sturdy construction, the modules have compact dimensions and a low weight. They are especially suitable for use in machines and installations with a moderate I/O concentration over separate assemblies.

3.3 EtherNet/IP product features

► Robust design:

The connection options provided by the module series are the widely-used M12 connector with D coding and the M12 hybrid connector for the EtherNet/IP network.

The connectors are also color-coded to prevent the ports from being mixed up.

► Data transmission rates:

Featuring a transmission rate of up to 100 MBit/s, the EtherNet/IP modules can handle both fast transmission of I/O data and transmission of larger volumes of data.

► Integrated switch:

The integrated Ethernet switch has two Ethernet ports and thus supports the establishment of a line or ring topology for the EtherNet/IP network.

► EtherNet/IP protocol:

The LioN-P IO-Link Master modules support the EtherNet/IP protocol. This allows the transmission of time sensitive process data between network components in real-time communication.

► Redundancy function:

In ring topologies, the firmware of the LioN-P modules supports the redundancy function DLR (Device Level Ring). With this function, if the connection is interrupted, the modules immediately switch to an alternative ring segment and thus ensure interruption-free operation. The DLR class supported is “beacon-based” according to the EtherNet/IP specification.

► Integrated web server:

The network parameters such as IP address, subnet mask and gateway can be adjusted using the rotary switch (last octet of the IP address) or the integrated web server. For automated assignment of the network parameters by the relevant server, the modules support the BOOTP and DHCP protocols.

► Diagnostics data:

The modules support extended diagnostics data that can be appended to the I/O data.

► EDS-based configuration and parameterization of the I/O ports:

You have the option of configuring and parameterizing the I/O ports on the master modules via EDS.

3.4 I/O port features

► The master modules support the IO-Link standard v1.1.

- Parametrization of the IO-Link Devices in EtherNet/IP via Class Code 0x80 and Read/Write ISDU services.
- Parametrization of the IO-Link Devices via Belden IO-Link Device Tool as a standalone PC-Application.

► 8 x IO-Link Master ports:

The modules have 4 Class A ports with an additional hard-wired digital input on pin 2 of the I/O port.

- Variants with a width of 30 mm:

4 x type B ports with electrically isolated auxiliary power supply on pins 2 and 5 of the I/O port with a total of 4 A current.

- Variants with a width of 60 mm:

4 x Class B ports with electrically isolated auxiliary power supply for up to 2 A per port on pins 2 and 5 with a total of 8 A current.

The auxiliary power supply can optionally be configured as a digital output.



Warning: If modules with electric isolation and modules without electric isolation are used within the same system, the electric isolation of all connected modules is cancelled.

► IO-Link port connections:

The IO-Link port connection option provided by the module series is the 5-pin M12 connector, or the 5-pin M8 connector.

▶ Parameter storage:

The parameter storage function stores and monitors the parameters of the IO-Link Device and IO-Link Master. The function thus gives you an easy option for replacing the IO-Link Device or IO-Link Master.

This is possible as of IO-Link specification V1.1 and only if the IO-Link Device and the IO-Link Master support the function.

▶ LED:

You can see the status of a port by the color of the matching LEDs and their flash pattern. For details on the meanings of the LED colors, please see section [LEDs](#) on page 137.

3.5 Integrated web server

▶ Network parameter display:

The integrated web server gives you the option of viewing network parameters such as the IP address, subnet mask and gateway.

▶ Displaying diagnoses:

You can view the diagnoses via the integrated web server.

▶ User management:

You can use the integrated web server for convenient management of all users.

▶ IO-Link Device parameters:

You can read the IO-Link Device parameters via the integrated web server and write new parameters in single write mode to the modules. Single write mode doesn't activate the automated parameter storage mechanism.

▶ Force Mode:

With the force mode output and input values can be set for implementation reasons.

3.6 Other features

▶ Interface protection:

The modules have reverse polarity, short-circuit and overload protection for all interfaces.

▶ Failsafe:

The modules support a failsafe function. This allows you to define the behavior of every single channel configured as an output in the case of an interruption or a loss of EtherNet/IP communication.

▶ Color-coded connectors:

Color-coded connectors help you avoid confusion in your cabling.

▶ IP protection classes IP65/IP67/IP69k:

The IP protection classes describe environmental influences that the modules can be exposed to without risk and without suffering damage, or causing a risk for the user.

Depending on the module, IP protection classes IP65, IP67 or IP69k are offered.

3.7 Product overview

The following IO-Link Masters are available for the LioN-P system:

Article number	Product designation	Description	Power & Ethernet ports	I/O ports
934 879 009	0980 ESL 398-121	LioN-P M12-60, IO-Link EtherNet/IP PROFINET	PWR - M12 L-coded ETH - M12 D-coded	8 x M12 (Up to 4 DO 1.6 A)
934 879 004	0980 ESL 399-121	LioN-P M12-60, IO-Link EtherNet/IP PROFINET	PWR - M12 L-coded ETH - M12 D-coded	8 x M12 (Up to 8 DO 0.5 A and up to 4 DO 2 A)
934 879 072	0980 ESL 399-121-EEC			
934 964 004	0980 ESL 199-121	LioN-P M12-30, IO-Link EtherNet/IP PROFINET	PWR - M12 L-coded ETH - M12 D-coded	8 x M12
934 964 002	0980 ESL 199-332	LioN-P M8-30, IO-Link EtherNet/IP PROFINET	PWR - M12 Hybrid ETH - M12 Hybrid	8 x M8
934 964 001	0980 ESL 199-331	LioN-P M12-30, IO-Link EtherNet/IP PROFINET	PWR - M12 Hybrid ETH - M12 Hybrid	8 x M12
934 964 003	0980 ESL 199-122	LioN-P M8-30, IO-Link EtherNet/IP PROFINET	PWR - M12 L-coded ETH - M12 D-coded	8 x M8

Table 2: Overview of module variants in the LioN-P series

As all variants can be used for EtherNet/IP and PROFINET networks, refer to the manual "**Manual_LioN_P_Multiprotocol_EN**" for setting the protocol.

4 Assembly and wiring

4.1 General information

Mount the module with 2 screws (M4x25 / 30) for LiON-P on a level surface. The torque required here is 1 Nm. Use washers for all fastening methods as per DIN 125. For the mounting holes, use the distance from the dimension schematics in chapter [Outer dimensions](#) on page 22.



Attention: The modules have a ground connection with an M4 thread for the conduction of interference currents and the EMC immunity. This is labeled with the symbol for the ground and the designation "XE".



Attention: Use a low-impedance connection to connect the module to the reference ground. When using a grounded mounting surface, you can make the connection directly via the fixing screws.



Attention: If the mounting surface is ground-free, use a ground strap or a suitable PE line. Use an M4 screw to connect the ground strap or the PE line to the ground point and if possible put a washer and a toothed washer below the fixing screw.



Attention: For UL application:

Be sure to use a UL-certified cable with a suitable evaluation to connect the devices (CYJV or PVVA).



Attention: To program the control, please refer to the OEM information, and only use suitable accessories.



Attention: For UL application:

Only approved for interior use. Please note the maximum elevation of 2000 meters. Approved up to a maximum soiling level of 2.



Warning: Terminals, housings field-wired terminal boxes or components can exceed temperatures of 60° C.



Warning: For UL application:

Use temperature-resistant cables with the following properties: For the module 0980 ESL 1x9-xxx heat-resistant up to at least 85° C. For the modules 0980 ESL 3x8-121 and 0980 ESL 3x9-121 heat-resistant up to at least 96° C.

4.2 Outer dimensions

4.2.1 Module 0980 ESL 398-121 & ESL 399-121

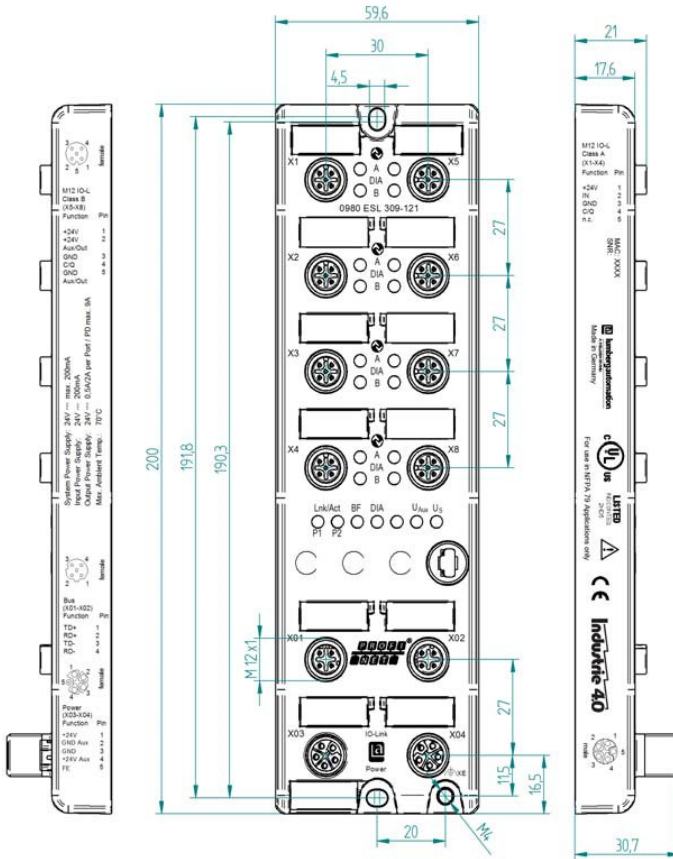

Figure 1: Dimension 0980 ESL 3xx-121

4.2.2 Module 0980 ESL 199-121

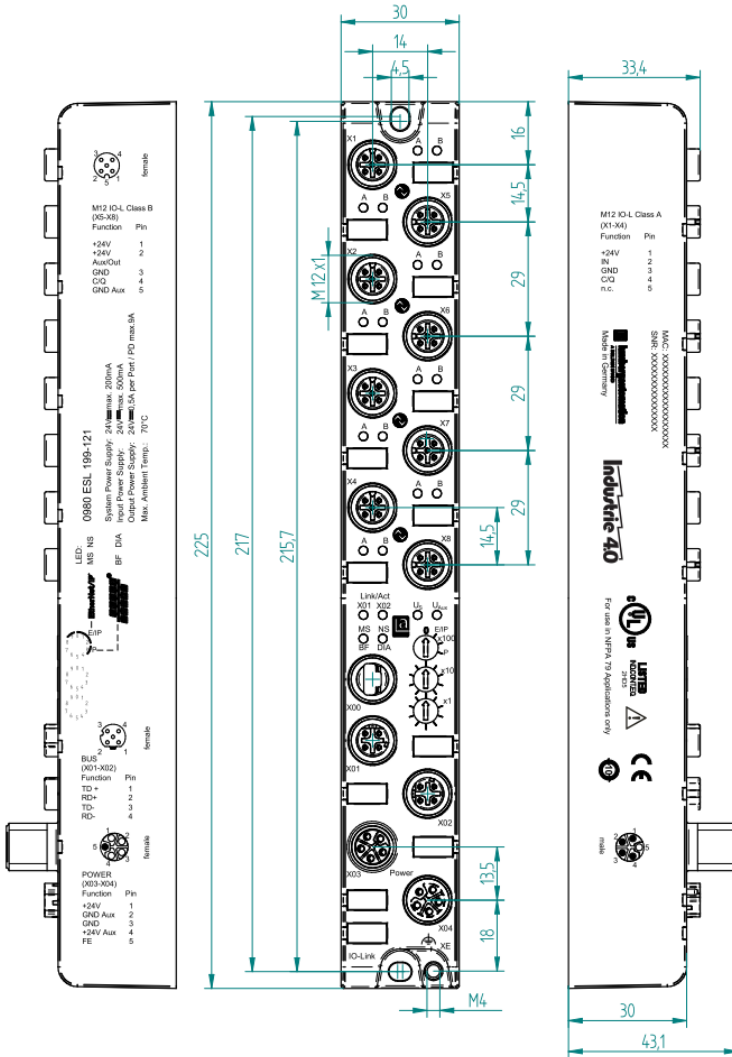

Figure 2: Dimension 0980 ESL 199-121

4.2.3 Module 0980 ESL 199-332

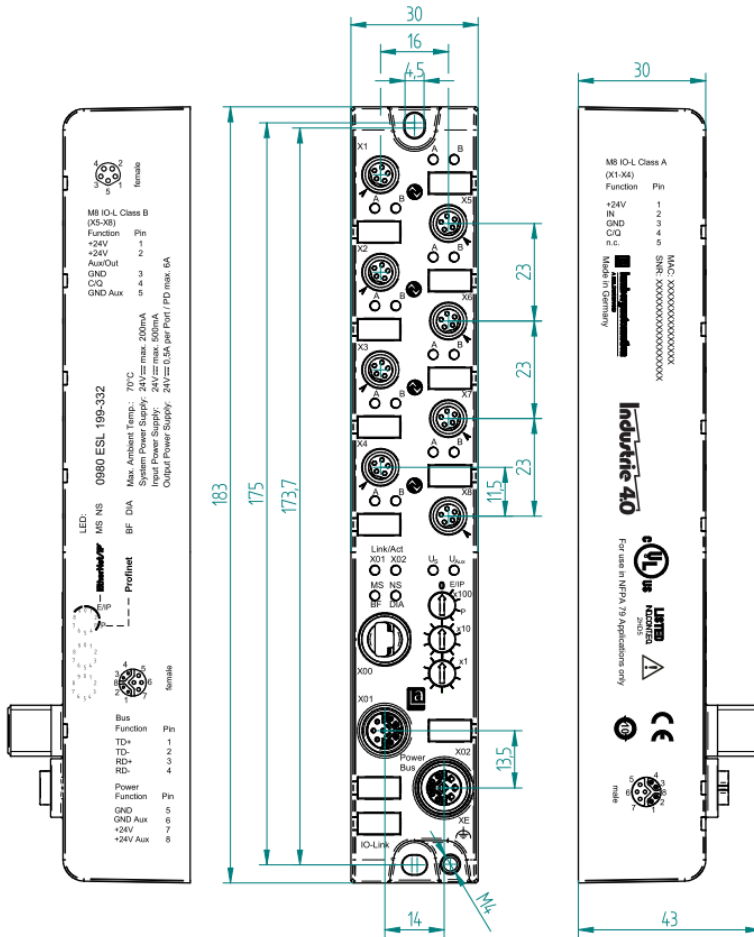

Figure 3: Dimension 0980 ESL 199-332

4.2.4 Module 0980 ESL 199-122

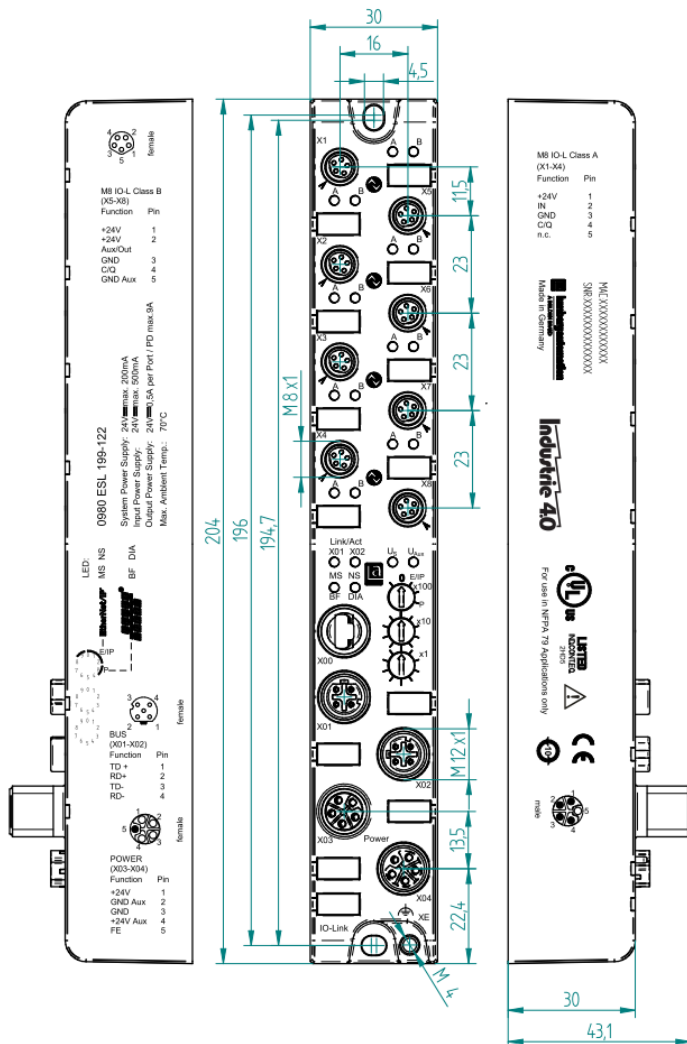

Figure 4: Dimension 0980 ESL199-122

4.2.5 Module 0980 ESL 199-331

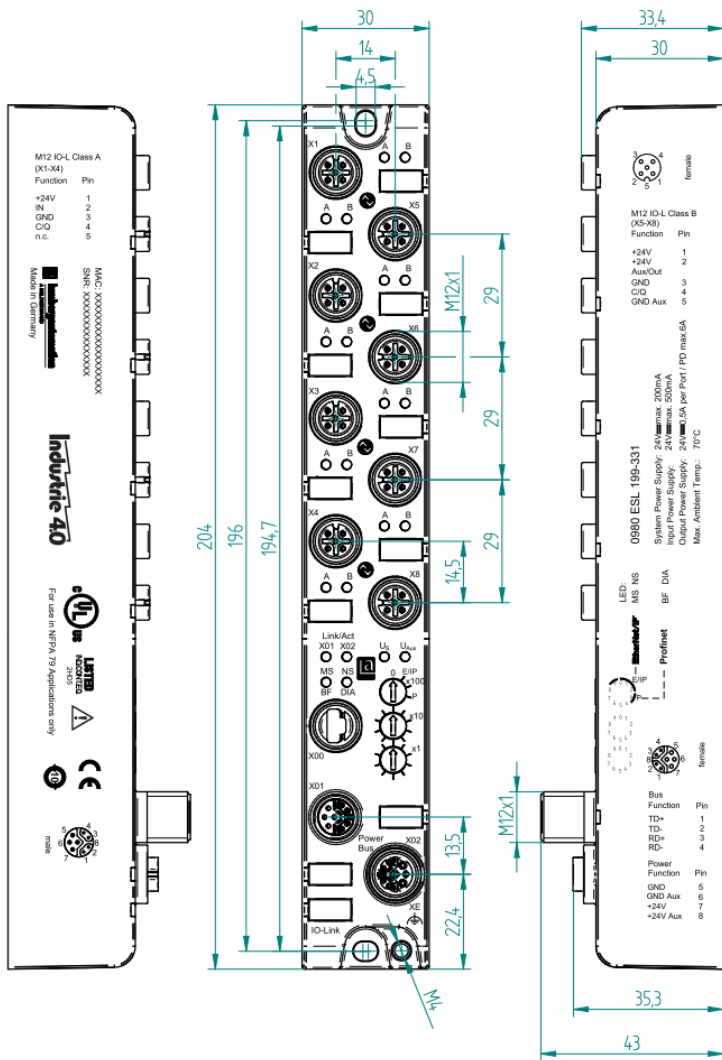

Figure 5: Dimension 0980 ESL 199-331

4.3 Port assignments

All the contact arrangements shown in this chapter show the frontal view of the connection area for the connectors.

4.3.1 Ethernet ports

- ▶ Design: M12 socket, 4-pin, D-coded
- ▶ Color coding: green

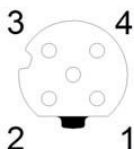

Figure 6: Schematic drawing, ports X01, X02

Port	Pin	Signal	Function
Ethernet X01, X02	1	TD+	Transmit data +
	2	RD+	Receive data -
	3	TD-	Transmit data -
	4	RD-	Receive data -

Table 3: Assignment of ports X01, X02



Caution: Risk of destruction! Never connect the power supply to the data cables.

4.3.2 Power supply with M12 power L-coded

► Color coding: gray

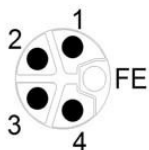

Figure 7: Schematic diagram of the M12 L-coding (connector), port X03 (IN)

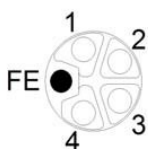

Figure 8: Schematic diagram of the M12 L-coding (socket), port X04 (OUT)

Power supply	Pin	Signal	Function
	1	U_S (+24 V)	Sensor/system power supply
	2	GND_ U_{Aux}	Ground/reference potential U_{Aux}
	3	GND_ U_S	System/sensors
	4	U_{Aux} (+24 V)	Auxiliary supply (electrically isolated)
	5	FE (PE)	Functional ground

Table 4: Power supply with M12-Power

i Attention: Only use power supply units for the system/sensor and actuator supply that correspond to PELV (protective extra low voltage) or SELV (safety extra low voltage). Power supplies according to EN 61558-2-6 (transformers) or EN 60950-1 (switching power supply units) fulfill these requirements.

4.3.3 EtherNet/IP and power supply with M12 Hybrid

► Color coding: gray

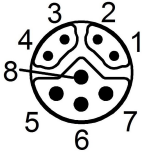

Figure 9: Schematic diagram of the M12 Hybrid (connector)

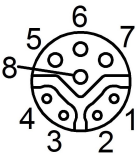

Figure 10: Schematic diagram of the M12 Hybrid (socket)

Ethernet + Power Supply	Pin	Signal	Function
	1	TD+	Transmit data plus
	2	RD+	Receive data plus
	3	TD-	Transmit data minus
	4	RD-	Receive data minus
	5	GND_U _S	Ground/reference potential GND_U _S
	6	GND_U _{Aux}	Ground/reference potential GND_U _{Aux}
	7	U _S (+24 V)	Sensor/system power supply
	8	U _{Aux} (+24 V)	Auxiliary supply (electrically isolated)

Table 5: EtherNet/IP and power supply with M12 Hybrid



Attention: Only use power supply units for the system/sensor and actuator supply that correspond to PELV (Protective Extra Low Voltage) or SELV (Safety Extra Low Voltage). Power supplies according to EN 61558-2-6 (transformers) or EN 60950-1 (switching power supply units) fulfill these requirements.

4.3.4 I/O ports as M8 or M12 sockets

4.3.4.1 IO-Link Type A

► Color coding: black

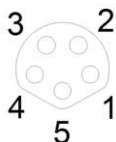

Figure 11: Schematic drawing I/O port as M8 socket IO-Link Type A

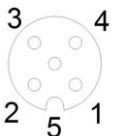

Figure 12: Schematic drawing I/O port as M12 socket IO-Link Type A

Port	Pin	Signal	Function
IO-Link Type A X1 - X4	1	L+	IO-Link sensor power supply +24 V
	2	IN-x	Ch. B: Digital input (Type 1)
	3	L-	IO-Link sensor supply GND_U _S
	4	C/Q	Ch. A: IO-Link data communication
	5	NC	not connected

Table 6: I/O ports as M8 or M12 socket IO-Link Type A

4.3.4.2 IO-Link Type B

► Color coding: black

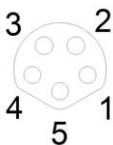

Figure 13: Schematic drawing I/O port as M8 socket IO-Link Type B

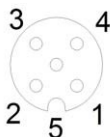

Figure 14: Schematic drawing I/O port as M12 socket IO-Link Type B

Port	Pin	Signal	Function
IO-Link Type B X5 - X8	1	L+	IO-Link sensor power supply +24 V
	2	U_{Aux} (+24 V)	Auxiliary power supply (electrically isolated with respect to the sensor/ system power supply)
	3	L-	IO-Link sensor supply GND_{US}
	4	C/Q	Ch. A: IO-Link data communication
	5	GND_{UAux}	Ground/reference potential U_{Aux}

Table 7: I/O ports as M8 or M12 socket IO-Link Type B



Warning: IO Port – Sensor supply:

The sensor supply may only be carried out via the specified power connection (Power X03 --> US +24 V/ GND_{US}) of the module. An external power supply over the IO port (Port X1-X8 --> Pin1/Pin3) is not permitted and can lead to a destruction of the module electronics!

**Warning:** IO Port connection (IO-Link - Class B):

The sensor supply (Port X5-X8 --> Pin1/Pin3) and the extended sensor supply (Port X5-X8 --> Pin2/Pin5) are galvanic isolated from each other. If the reference potentials (GND_US - Pin3) and (GND_UAux - Pin5) are connected, unacceptable compensation currents can flow. In this case the connection of a sensor at (Port X5-X8 --> Pin2) is not allowed!

The removal of the galvanic separation is not recommended.

5 Starting operation

5.1 Downloading and installing the EDS file

An EDS file is required for the configuration of a module in the controller. Each of the variants requires its own EDS file. You have the option of downloading the EDS file from our website or asking our support team to send it to you. The address of the website is:

http://www.beldensolutions.com/en/Service/download_center/.

The EDS files are grouped together in an archive file with the name
LioN-P ETHERNET-IP IO-Link EDS V3.11.1.

1. Download this file and unpack it.

The archive contains the following EDS files:

- ▶ EDS-V3.11.1-LumbergAutomation-0980ESL199-121-yyyymmdd.eds
- ▶ EDS-V3.11.1-LumbergAutomation-0980ESL199-122-yyyymmdd.eds
- ▶ EDS-V3.11.1-LumbergAutomation-0980ESL199-331-yyyymmdd.eds
- ▶ EDS-V3.11.1-LumbergAutomation-0980ESL199-332-yyyymmdd.eds
- ▶ EDS-V3.11.1-LumbergAutomation-0980ESL398-121-yyyymmdd.eds
- ▶ EDS-V3.11.1-LumbergAutomation-0980ESL399-121-yyyymmdd.eds

yyyymmdd stands for the date on which the file was issued.

2. Install the EDS file for the module variant in use with the aid of the hardware or network configuration tool of your controller manufacturer.

After installation, the modules are available in the hardware catalogs as a **Communications Adapter** device.

5.2 Reading the MAC addresses

Every module has three unique MAC addresses assigned by the manufacturer that cannot be changed by the user. The first assigned MAC address is printed on the module.

5.3 Setting the network parameters

You can use the 3 rotary switches on the front of the modules to set the operation mode for receiving the network parameters such as IP address, subnet mask, and gateway address.

After the power supply is restored, the modules read the switch settings. The selected operation mode overwrites the stored settings.

The devices support the DHCP and BOOTP protocols for receiving the required network parameters such as IP address and subnet mask. The factory settings of the static network parameters are:

IP address:	192.168.100.001 ³
Subnet mask:	255.255.255.000
Gateway address:	000.000.000.000

Using the rotary encoding switches, the following settings are possible for EtherNet/IP LioN-P modules:

Rotary switch setting	Function
000 (state on delivery)	In the state on delivery, the DHCP and BOOTP functions are activated. The network parameters are initially requested via DHCP requests. If this is not successful, BOOTP requests are used. The network parameters are not saved, but the integrated web server can be used to save them.
000 (network parameters already saved)	The network parameters last saved are used (IP address, subnet mask, gateway address, DHCP on/off, BOOTP on/off).
001 ... 254	The last 3 digits of the saved or preset IP address are overwritten by the setting of the rotary switch.
255 ... 298	The network parameters are requested via DHCP and BOOTP but are not saved.
299	The factory setting of the IP address (192.168.100.001 ³) is used.
979	The device performs a reset to the factory settings. The network parameters are also reset to the default values. Communication is not possible in this operation mode.

Table 8: Setting options of the rotary encoding switches for EtherNet/IP modules

For additional multiprotocol information, refer the manual **Manual_LioN_P_Multiprotocol_EN.pdf**.

³ Applies from V1.1.0.10; IP address for versions prior to V1.1.0.10: 192.168.001.001

5.4 Configuration of the device with RsLogix 5000

The configuration and start-up of the modules described on the following pages refers to the RSLogix 5000 software from Rockwell Automation. If you are using a control system from another provider, please consider the related documentation.

1. Install the EDS files of the modules in **RSLogix 5000** with the EDS Hardware Installation Tool in the **Tools** menu.
2. Select the correct controller.
3. Go to the **I/O-Configuration** section in the **Controller Organizer** and right-click **Ethernet**.
4. Select the **New Module** menu item. The following selection window opens.

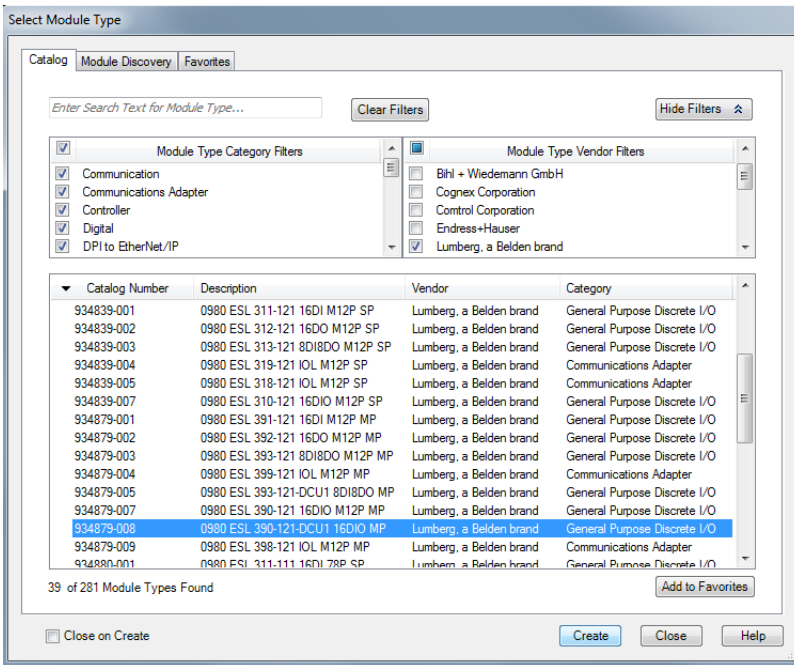

5. Use the **Module Type Vendor Filter** on the right side to display all installed modules of Lumberg, a Belden brand.

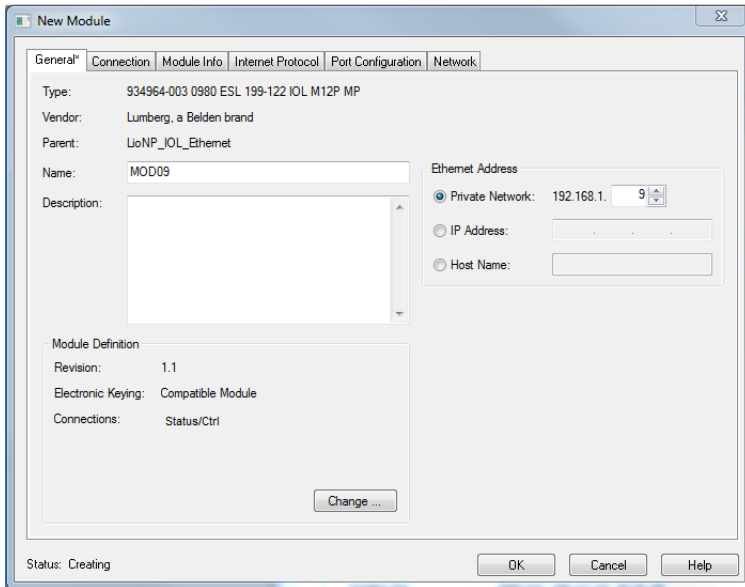
6. Select the module to be added and click the **Create button.**

- 7. Enter a name for the module and the correct IP address. In this example, the name is **MOD09** and the IP address is **192.168.1.9**.**
- 8. Click the **Change** button in order to change the settings for the module revision, electronic keying, and connection type.**

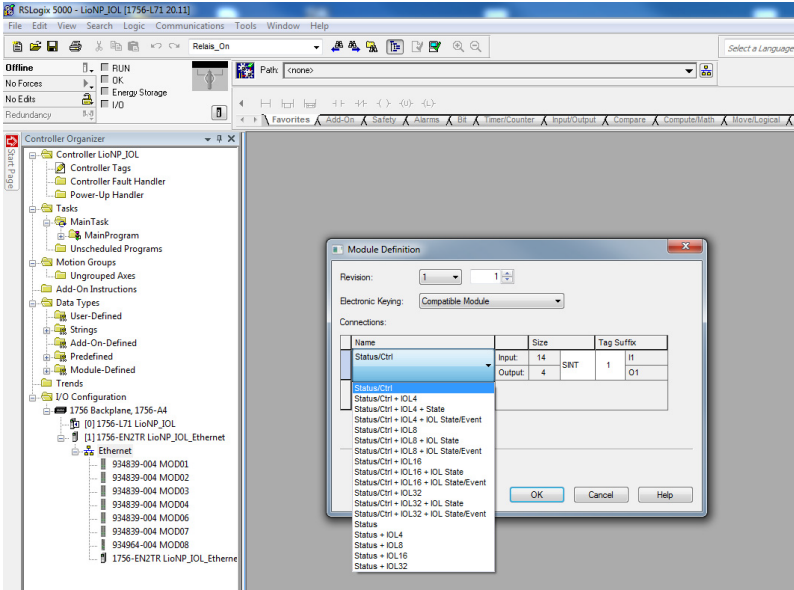

9. Select the connection type. This specifies which process and diagnostic data the module provides. The connections and its assemblies are described in chapter [Connections](#) on page 63.
10. In the **Connections** folder of the **Module Properties**, you will see the selected connection type. This folder also lets you define the **Requested-Packet-Interval (RPI)** and the input type (**Input Type**). A value of 1 ms is the minimum for parameter RPI.

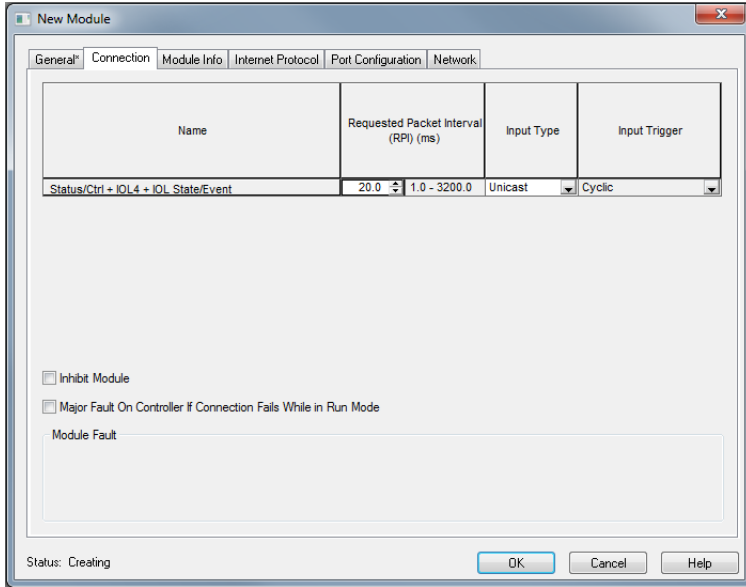

11. Move to the **Controller-Tags** section in **Controller Organizer**. The controller tags for the configuration parameters contain the name of the module, followed by a **":C"**. The configuration parameters can be set in the **Value** column and are described in chapter [Parameter of the IO-Link Master](#) on page 41.

Name	Value	Force Mask	Style	Data Type
MOD09:C	{...}	{...}		0015:934964_0...
+ MOD09:C.General_Device_Settings	2#0000_0010		Binary	SINT
- MOD09:C.Mapping_Mode_2	0		Decimal	BOOL
- MOD09:C.Force_Mode_Lock	1		Decimal	BOOL
- MOD09:C.Web_Interface_Lock_over_TCP	0		Decimal	BOOL
- MOD09:C.Reserved	0		Decimal	BOOL
- MOD09:C.Web_Interface_Lock_over_USB	0		Decimal	BOOL
+ MOD09:C.Global_Diagnosis_Settings_1	2#0110_0000		Binary	SINT
- MOD09:C.Disable_Alarms	0		Decimal	BOOL
- MOD09:C.Disable_IOL_Master_Alarms	0		Decimal	BOOL
- MOD09:C.Disable_IOL_Device_Errors	0		Decimal	BOOL
- MOD09:C.Disable_IOL_Device_Warnings	0		Decimal	BOOL
- MOD09:C.Disable_IOL_Device_Notifications	0		Decimal	BOOL
- MOD09:C.Disable_Uaux_Supply_Alarms	1		Decimal	BOOL
- MOD09:C.Disable_Actuator_Error	1		Decimal	BOOL
+ MOD09:C.Global_Diagnosis_Settings_2	2#0000_0000		Binary	SINT
- MOD09:C.Disable_IOL_Device_Diagnosis_Port_1	0		Decimal	BOOL
- MOD09:C.Disable_IOL_Device_Diagnosis_Port_2	0		Decimal	BOOL
- MOD09:C.Disable_IOL_Device_Diagnosis_Port_3	0		Decimal	BOOL
- MOD09:C.Disable_IOL_Device_Diagnosis_Port_4	0		Decimal	BOOL
- MOD09:C.Disable_IOL_Device_Diagnosis_Port_5	0		Decimal	BOOL
- MOD09:C.Disable_IOL_Device_Diagnosis_Port_6	0		Decimal	BOOL
- MOD09:C.Disable_IOL_Device_Diagnosis_Port_7	0		Decimal	BOOL
- MOD09:C.Disable_IOL_Device_Diagnosis_Port_8	0		Decimal	BOOL

6 Parameter of the IO-Link Master

The following chapter describes the parameter of the IO-Link Master. The parameter must be transferred to the IO-Link Master after powering-up. The parameter contains among other things also the IO-Link port mode. The IO-Link port data length is chosen out of the different available connections.

The default settings in the following tables are highlighted.

6.1 General Device Settings

Param. No.	Function	Bit	Description
1	General device settings	0	0 = Mapping Mode 1 1 = Mapping Mode 2
		1	0 = Force mode via web interface enabled 1 = Force mode via web interface disabled
		2	0 = Web interface over TCP enabled 1 = Web interface over TCP disabled
		3	0 = Auto Restart after failure (Ports 5 - 8) disabled 1 = Auto Restart after failure (Ports 5 - 8) enabled
		4	0 reserved
		5	0 reserved
		6	0 reserved
		7	0 reserved

Table 9: General device settings

6.1.1 Mapping Mode, Bit 0

The **Digital-I/O Bit Mapping Mode** parameter can be used to define the mappings of the input/output bits that are transmitted in the cyclical status and control data of the Module.

► MM1: Default Mapping

In Mapping Mode 1 (MM1), the first channel bit (C/Q, Ch. A / Pin 4) and the second channel bit (Ch. B / Pin 2) are transmitted alternately in ascending order for all ports.

► MM2: E2C Compatible Mapping

In Mapping Mode 2 (MM2), the first channel bits (C/Q, Ch. A / Pin 4) and the second channel bits (Ch. B / Pin 2) are transmitted consecutively in ascending order for all ports.

The different formats are also shown in chapter [Connections](#) on page 63.

6.2 Global diagnosis parameter

Param. No.	Function	Bit	Description
2	Global diagnosis parameter	0	0 = All diagnosis enabled 1 = All diagnosis disabled
		1	0 = IO-Link Master diagnosis enabled 1 = IO-Link Master diagnosis disabled
		2	0 = IO-Link Device error diagnosis enabled 1 = IO-Link Device error diagnosis disabled
		3	0 = IO-Link Device warning diagnosis enabled 1 = IO-Link Device warning diagnosis disabled
		4	0 = IO-Link Device notification diagnosis enabled 1 = IO-Link Device notification diagnosis disabled
		5	0 = U _{Aux} supply diagnosis enabled (default 0980 ESL 3x8-121) 1 = U_{Aux} supply diagnosis disabled
		6	0 reserved, do not use
		7	0 reserved, do not use

Table 10: Global diagnosis parameter 2

Param. No.	Function	Bit	Description
3	Global diagnosis parameter	0	0 = IO-Link port 1 device diagnosis enabled 1 = IO-Link port 1 device diagnosis disabled
		1	0 = IO-Link port 2 device diagnosis enabled 1 = IO-Link port 2 device diagnosis disabled
		2	0 = IO-Link port 3 device diagnosis enabled 1 = IO-Link port 3 device diagnosis disabled
		3	0 = IO-Link port 4 device diagnosis enabled 1 = IO-Link port 4 device diagnosis disabled
		4	0 = IO-Link port 5 device diagnosis enabled 1 = IO-Link port 5 device diagnosis disabled
		5	0 = IO-Link port 6 device diagnosis enabled 1 = IO-Link port 6 device diagnosis disabled
		6	0 = IO-Link port 7 device diagnosis enabled 1 = IO-Link port 7 device diagnosis disabled
		7	0 = IO-Link port 8 device diagnosis enabled 1 = IO-Link port 8 device diagnosis disabled

Table 11: Global diagnosis parameter 3

6.3 Failsafe parameter for digital outputs

The IO-Link Master supports a failsafe function for the channels used as digital outputs. While the devices are being configured, the status of the outputs can be defined after an interruption or loss of communication on the EtherNet/IP network.

The following options can be selected:

- ▶ **Set Low:** the output channel is disabled and/or the output bit set to 0.
- ▶ **Set High:** the output channel is enabled and/or the output bit set to 1.
- ▶ **Hold Last:** the last output state is being kept.

Param. No.	Function	Bit	Description
4	Failsafe Value DO Mode Port 1 Channel A	0 – 1	0 = Set Low 1 = Set High 2 = Hold Last
		2 – 7	0 = reserved, do not change
5	Failsafe Value DO Mode Port 2 Channel A	0 – 1	0 = Set Low 1 = Set High 2 = Hold Last
		2 – 7	0 = reserved, do not change
6	Failsafe Value DO Mode Port 3 Channel A	0 – 1	0 = Set Low 1 = Set High 2 = Hold Last
		2 – 7	0 = reserved, do not change
7	Failsafe Value DO Mode Port 4 Channel A	0 – 1	0 = Set Low 1 = Set High 2 = Hold Last
		2 – 7	0 = reserved, do not change
8	Failsafe Value DO Mode Port 5 Channel A	0 – 1	0 = Set Low 1 = Set High 2 = Hold Last
		2 – 7	0 = reserved, do not change
9	Failsafe Value DO Mode Port 6 Channel A	0 – 1	0 = Set Low 1 = Set High 2 = Hold Last
		2 – 7	0 = reserved, do not change
10	Failsafe Value DO Mode Port 7 Channel A	0 – 1	0 = Set Low 1 = Set High 2 = Hold Last
		2 – 7	0 = reserved, do not change
11	Failsafe Value DO Mode Port 8 Channel A	0 – 1	0 = Set Low 1 = Set High 2 = Hold Last
		2 – 7	0 = reserved, do not change

Param. No.	Function	Bit	Description
40	Failsafe Value DO Mode Port 1 Channel B	0 – 1	DO not available, do not change
		2 – 7	0 = reserved, do not change
41	Failsafe Value DO Mode Port 2 Channel B	0 1	DO not available, do not change
		2 – 7	0 = reserved, do not change
42	Failsafe Value DO Mode Port 3 Channel B	0 – 1	DO not available, do not change
		2 – 7	0 = reserved, do not change
43	Failsafe Value DO Mode Port 4 Channel B	0 – 1	DO not available, do not change
		2 – 7	0 = reserved, do not change
12	Failsafe Value DO Mode Port 5 Channel B (LioN-P 60 only)	0 – 1	0 = Set Low 1 = Set High 2 = Hold Last
		2 – 7	0 = reserved, do not change
13	Failsafe Value DO Mode Port 6 Channel B (LioN-P 60 only)	0 – 1	0 = Set Low 1 = Set High 2 = Hold Last
		2 – 7	0 = reserved, do not change
14	Failsafe Value DO Mode Port 7 Channel B (LioN-P 60 only)	0 – 1	0 = Set Low 1 = Set High 2 = Hold Last
		2 – 7	0 = reserved, do not change
15	Failsafe Value DO Mode Port 8 Channel B (LioN-P 60 only)	0 – 1	0 = Set Low 1 = Set High 2 = Hold Last
		2 – 7	0 = reserved, do not change
16	Reserved 1	0 – 8	0 = reserved, do not change

Table 12: Failsafe parameter for digital outputs

6.4 Surveillance timeout parameter, LioN-P 60

For LioN-P 60 devices, the separate power supply U_{Aux} , which is available on type B IO-Link channels (Ch.B / Pin 2), ports 5-8 can also be configured as an additional digital output (See table [Table 15: Digital I/O mode channel B](#) on page 50.). This gives you the option of switching the power supply like a digital output.

The firmware of the modules allows you to configure a delay time before output current monitoring is enabled for this special use case.

The delay time is referred to as the Surveillance-Timeout and can be configured for each output channel. The delay time begins after the state of the output channel changes, i.e., when it is activated (after a rising edge) or deactivated (after a falling edge). After this time has elapsed the output is monitored and error states are reported by diagnostics.

The Surveillance-Timeout parameter can be set from 0 to 255 ms. The default value of this parameter is 80 ms. When an output channel is in static state, i.e., when the channel is permanently switched on or off the typical value is 5 ms.

Param. No.	Function	Bit	Description
20	Surveillance Timeout Port 1 Channel B	0 – 16	0 = DO not available, reserved
21	Surveillance Timeout Port 2 Channel B	0 – 16	0 = DO not available, reserved
22	Surveillance Timeout Port 3 Channel B	0 – 16	0 = DO not available, reserved
23	Surveillance Timeout Port 4 Channel B	0 – 16	0 = DO not available, reserved
24	Surveillance Timeout Port 5 Channel B	0 – 16	0 ms = Min. Value 80 ms = Default Value 255 ms = Max. Value

Param. No.	Function	Bit	Description
25	Surveillance Timeout Port 6 Channel B	0 – 16	0 ms = Min. Value 80 ms = Default Value 255 ms = Max. Value
26	Surveillance Timeout Port 7 Channel B	0 – 16	0 ms = Min. Value 80 ms = Default Value 255 ms = Max. Value
27	Surveillance Timeout Port Channel B	0 – 16	0 ms = Min. Value 80 ms = Default Value 255 ms = Max. Value

Table 13: Surveillance Timeout

6.5 Digital input logic

The standard input logic (normally open) can be inverted to normally closed. In case of normally closed setting a high level will be transferred to the EtherNet/IP scanner for a physical low level at the digital input port. The port LED logic remains unchanged from the input logic settings. The LED shows the physical input status of the port.

Param. No.	Function	Bit	Description
28	Digital Input Logic Channel A	0	0 = Normally Open Port 1A 1 = Normally Closed Port 1A
		1	0 = Normally Open Port 2A 1 = Normally Closed Port 2A
		2	0 = Normally Open Port 3A 1 = Normally Closed Port 3A
		3	0 = Normally Open Port 4A 1 = Normally Closed Port 4A
		4	0 = Normally Open Port 5A 1 = Normally Closed Port 5A
		5	0 = Normally Open Port 6A 1 = Normally Closed Port 6A
		6	0 = Normally Open Port 7A 1 = Normally Closed Port 7A
		7	0 = Normally Open Port 8A 1 = Normally Closed Port 8A

Param. No.	Function	Bit	Description
29	Digital Input Logic Channel B	0	0 = Normally Open Port 1B 1 = Normally Closed Port 1B
		1	0 = Normally Open Port 2B 1 = Normally Closed Port 2B
		2	0 = Normally Open Port 3B 1 = Normally Closed Port 3B
		3	0 = Normally Open Port 4B 1 = Normally Closed Port 4B
		4	0 = Input not available, do not change
		5	0 = Input not available, do not change
		6	0 = Input not available, do not change
		7	0 = Input not available, do not change

Table 14: Digital input logic

6.6 Digital I/O mode channel B, LioN-P 60

With this parameters the function for the ports 5 - 8 (IO-Link type B) of channel B can be chosen.

Param. No.	Function	Bit	Description
30	Digital I/O Mode Port 1, Channel B	0 - 7	0 = Digital-Input, function not changeable
31	Digital I/O Mode Port 2, Channel B	0 - 7	0 = Digital-Input, function not changeable
32	Digital I/O Mode Port 3, Channel B	0 - 7	0 = Digital-Input, function not changeable
33	Digital I/O Mode Port 4, Channel B	0 - 7	0 = Digital-Input, function not changeable
34	Digital I/O Mode Port 5, Channel B	0 - 1	0 = Reserved 1 = Auxiliary Power 2 = Digital Output 3 = Inactive
		2 - 7	0 = reserved, do not change
35	Digital I/O Mode Port 6, Channel B	0 - 1	0 = Reserved 1 = Auxiliary Power 2 = Digital Output 3 = Inactive
		2 - 7	0 = reserved, do not change
36	Digital I/O Mode Port 7, Channel B	0 - 1	0 = Reserved 1 = Auxiliary Power 2 = Digital Output 3 = Inactive
		2 - 7	0 = reserved, do not change

Param. No.	Function	Bit	Description
37	Digital I/O Mode Port 8, Channel B	0 - 1	0 = Reserved 1 = Auxiliary Power 2 = Digital Output 3 = Inactive
		2 - 7	0 = reserved, do not change

Table 15: Digital I/O mode channel B

► **Auxiliary Power:**

In this mode, Pin 2 and Pin 5 of the type B IO-Link ports (ports 5 - 8) act as an auxiliary voltage output. The auxiliary voltage is fed from the U_{Aux} supply input. The auxiliary voltage output cannot be controlled.

► **Digital Output (DO):**

In this mode, ch. B/Pin 2 of the type B IO-Link ports (ports 5 - 8) can be used as a digital output. The control bits are transferred by the digital output control bytes to the device. A Surveillance-Timeout can be parameterized for the outputs (See table [Table 13: Surveillance Timeout](#) on page 46.).

6.7 IO-Link port mode parameter (channel A)

With this parameter, the function of the channel A IO-Link ports can be selected. The following modes are available:

► **Inactive:**

This mode should be selected if the channel is not used. In this case, the L+ power supply (Pin 1) of the port will be disabled.

► **Digital Input:**

In this mode, the channel operates as a digital input. The IO-Link Master does not try to independently establish communication to a connected IO-Link Device.

However, the cyclical output bits in the ComCntrl byte of the IO-Link Master can be used to set the appropriate channels in COM mode and thus enable the IO-Link Device for parameterization.

► **Digital Output:**

In this mode, the channel operates as a digital output. It is impossible at any time to communicate with the connected device. The **Digital Output** option for the IO-Link C/Q channel (ch. A/Pin 4) is not available for the 0980 ESL 3x8-121 device.

► **SIO mode (DI):**

This mode is used to parameterize the IO-Link Devices. It relies on the fallback mechanism from COM mode to SIO mode. In this mode, the IO-Link Device can be parameterized during the module's startup time and changes back to digital input mode via the fallback mechanism.

Additionally, the cyclical output bits in the COM control byte (chapter [Control of IO-Link COM mode](#) on page 100) of the IO-Link Master can be used at any time to set the appropriate channels in COM mode thus enable the IO-Link Device for parameterization.



Attention: Please note that the status of the digital input signal will not be updated during optional COM operations.

► **IO-Link:**

In this mode (COM mode) the process data from or to the device is exchanged over a communication link. The IO-Link Master starts communicating with the connected IO-Link Device automatically taking into account the baud rate. Additionally, this mode offers the option of parameterizing the IO-Link Device.

Connections with data lengths of 4, 8, 16 and 32 input and output bytes are available. If no suitable connection is available for the device, the next larger data length has to be selected.

Param. No.	Function	Bit	Description
53	Digital I/O Mode Port 1, Channel B	0 - 2	0 = Inactive 1 = DI 2 = DO 3 = SIO 4 = IO-Link
		3 - 7	0 = reserved, do not change
54	Digital I/O Mode Port 2, Channel B	0 - 2	0 = Inactive 1 = DI 2 = DO 3 = SIO 4 = IO-Link
		3 - 7	0 = reserved, do not change
55	Digital I/O Mode Port 3, Channel B	0 - 2	0 = Inactive 1 = DI 2 = DO 3 = SIO 4 = IO-Link
		3 - 7	0 = reserved, do not change
56	Digital I/O Mode Port 4, Channel B	0 - 2	0 = Inactive 1 = DI 2 = DO 3 = SIO 4 = IO-Link
		3 - 7	0 = reserved, do not change

Param. No.	Function	Bit	Description
57	Digital I/O Mode Port 5, Channel B	0 - 2	0 = Inactive 1 = DI 2 = DO 3 = SIO 4 = IO-Link
		3 - 7	0 = reserved, do not change
58	Digital I/O Mode Port 6, Channel B	0 - 2	0 = Inactive 1 = DI 2 = DO 3 = SIO 4 = IO-Link
		3 - 7	0 = reserved, do not change
59	Digital I/O Mode Port 7, Channel B	0 - 2	0 = Inactive 1 = DI 2 = DO 3 = SIO 4 = IO-Link
		3 - 7	0 = reserved, do not change

Table 16: IO-Link port mode

6.8 IO-Link port extended parameter

For every IO-Link port (Channel A) the "Parameter Storage" and "Validation Mode" of the IO-Link Master can be set. For every IO-LinkIO-Link port there is a parameter block of 22 Bytes available.

Param. No.	Function	Bit	Description
62 ... 70	IO-L Port 1 Parameter		See the following table
72 ... 80	IO-L Port 2 Parameter		See the following table
82 ... 90	IO-L Port 3 Parameter		See the following table
92 ... 100	IO-L Port 4 Parameter		See the following table
102 ... 110	IO-L Port 5 Parameter		See the following table
112 ... 120	IO-L Port 6 Parameter		See the following table
122 ... 130	IO-L Port 7 Parameter		See the following table
132 ... 140	IO-L Port 8 Parameter		See the following table

Table 17: IO-Link port extended parameter overview

Param. No.	Function	Bit	Description
62	Parameter Storage Port 1	0 - 3	0 = Disabled 1 = Download (master to device) 2 = Upload (device to master) 3 = Download & Upload 4 = Disabled & Cleared
		4 - 7	0 = reserved, do not change
63	Device Validation Mode Port 1	0 - 3	0 = No Validation 1 = Compatible with entered values 2 = Identical with entered values
		4 - 7	0 = reserved, do not change
64	Vendor ID (MSB) Port 1	0 - 7	0 ... 255
65	Vendor ID (LSB) Port 1	0 - 7	0 ... 255
66	Device ID (MSB) Port 1	0 - 7	0 ... 255
67	Device ID Port 1	0 - 7	0 ... 255
68	Device ID (LSB) Port 1	0 - 7	0 ... 255
69	Serial Number of IO-Link Device Port 1 (16 Bytes)	0 - 7	Serial Number Byte 1 (MSB)
	
		0 - 7	0 - 7 Serial Number Byte 16 (LSB)
70	Fail Safe Behavior IO-Link Port 1	0 - 3	0 = Set Low 1 = Set High 2 = Hold Last Value 3 = Replacement Value (transferred via Class Code 0x81) 4 = Command
		4 - 7	0 = reserved, do not change

Table 18: IO-Link port extended parameter

6.8.1 IO-L Parameter storage

With the parameters 62, 72, 82, 92, 102, 112, 122 and 132 the parameter storage options are adjustable for every IO-Link port. The **Parameter storage** function manages the IO-Link Device parameters to enable a simple device or master replacement.

The following options can be set:

► **Disabled:**

Disabled mode is the default setting in as-delivered condition. The data maintenance function is disabled. If parameter data of a device were stored previously, these data remain stored without any changes.

► **Download only** (master to device):

Enables the parameter data download function to the IO-Link Device on the master.

Parameter data can only be uploaded to an IO-Link Device if they exist on the parameter server and are usable for the device. When an IO-Link Device is connected, the master compares the stored parameter data with the device data. If the function is not locked on the device (**Parameter storage** locked), the master downloads the stored data to the device in case of differences.

IO-Link Device data can be loaded using the **Upload only** mode. If the master does not have a device parameter set stored, the mode must be compared with **Disabled**.

Replacement of the IO-Link Device is possible in this mode.

► **Upload only** (device to master):

Enables the parameter data upload function to the IO-Link Master from the device.

An upload is performed when an IO-Link Device is connected and the master does not have any valid data. This is the case if **Disabled and Cleared** mode was configured previously and/or in case of **Disabled** in as-delivered condition.

If parameter data are changed on the device during runtime, the device data stored on the master can be overwritten using the ParamDownloadStore (Index 0x0002, Subindex 0x00, Value 0x05) command. This command sets the DS_UPLOAD_REQ flag on the device, and thus executes an upload.

The IO-Link Master can be replaced in this mode.

► **Download and Upload:**

Enables the IO-Link parameter data download and upload function. An upload is performed when an IO-Link Device is connected and the master does not have any valid data. This is the case if **Disabled and Cleared** mode was configured previously and/or in case of **Disabled** in as-delivered condition. The parameter data read are permanently stored on the master.

If parameter data are changed on the device during runtime, the device data stored on the master can be overwritten using the ParamDownloadStore (Index 0x0002, Subindex 0x00, Value 0x05) command. This command sets the DS_UPLOAD_REQ flag on the device, and thus executes an upload.

For each new connection to an IO-Link Device, the master compares the stored parameter data with the device data. If the function is not locked on the device (**Parameter storage** locked), the master downloads the stored data to the device in case of differences. The IO-Link Device can be replaced in this mode.

Action	IO-Link Master State	IO-Link Device State
Upload	Invalid Data (Cleared before)	Upload Flag active (Valid Data)
Upload	Invalid Data (Cleared before)	Upload Flag not active & Valid Data
Upload	Valid Data	Upload Flag active & Valid Data
Download	Valid Data	Upload Flag not active (data equal)

Table 19: Download and upload states

► **Disabled and Cleared:**

The data retention function is disabled and stored data are deleted.



Attention: The IO-Link Device sets the Upload Flag self-dependent when parameters were written in block mode.

6.8.2 IO-L Device Validation

The IO-L Device Validation (IO-Link Device Identification) lets you check the connected devices for the values set in the control program in order to, e.g., identify correctly connected devices and not start operations with them.

► Validation Mode

- No Validation

This option is the default setting. In this case, neither the VendorID, DeviceID, nor the serial number are synchronized after powering on between the IO-Link Device and the entered IO-Link Master data before communication starts.

- Compatible with entered values

With this option, the VendorID and DeviceID are synchronized after powering on between the IO-Link Device and the entered IO-Link Master data before communication starts. Process data communication is only established if the configured values match the values reported by the device.

Replacement of the an IO-Link Device of the same type is thus possible without changes in the Engineering Tool.

- Identical with entered values

In this case, the VendorID, DeviceID and serial number are synchronized after powering on between the IO-Link Device and the entered IO-Link Master data before communication starts. Process data communication is only established if the configured values match the values reported by the device.

Replacement of an IO-Link Device of the same type is thus only possible if the serial number is changed in the Engineering Tool at the same time.

- VendorID

The VendorID of the IO-Link Device used can be entered as a decimal value in the VendorID (MSB) (high-order byte) and VendorID (LSB) (low-order byte) fields.

- DeviceID

The DeviceID of the IO-Link Device used can be entered as a decimal value in the DeviceID (MSB) (high-order byte) and DeviceID (LSB) (low-order byte) fields.

- Serial Number

The serial number of the IO-Link Device can be entered as a string in the **Serial Number** input field. The input is limited to 16 characters.

6.8.3 Fail Safe Behavior (for outputs only)

This option is only applicable for IO-Link channels in COM mode where output data are used. In COM mode, the I/O data are exchanged between the IO-Link Master and IO-Link Device via serial communication.

► Fail Safe Value Options

The following values are selectable:

- Set Low

All bits of the output data with a value of 0 are transmitted to the IO-Link Device (Default setting).

- Set High

All bits of the output data with a value of 1 are transmitted to the IO-Link Device.

- Hold Last

The last valid output value received by the control unit is continuously and cyclically transmitted to the IO-Link Device.

- Replacement Value

If this option is selected, the values transferred via the IO-Link failsafe parameter Object (Class-Code 0x81) will be continuously and cyclically transmitted to the IO-Link Device.

Refer to chapter [IO-Link failsafe parameter Object \(Class-Code 0x81\)](#) on page 119 for transferring the replacement values to the IO-Link Master.

- IO-Link Master command

The **IO-Link-Master-Command** option allows the use of IO-Link specific mechanisms for valid/invalid output process data. Thus, the device itself determines the behavior.

7 Connections

The LioN-P EtherNet/IP IO-Link Master supports different fixed I/O data connections.

With the input data, actual values are specified, and with the output data target values.

7.1 Exclusive Owner Connections

The Exclusive Owner connections can be configured as multicast or point to point connection in target to originator direction.

► Size of input data

The amount of provider data (input data) is variable and depends from the chosen connection number.

The first block of data within the input data is always the status data block. This block contains the digital input states of the I/O ports, IO-Link port states and diagnosis data. The amount of input data depends from the configured IO-Link input/output data size.

► Configured IO-Link input/output data size

The IO-Link input/output data can be chosen in length of 4, 8, 16 or 32 bytes for all IO-Link channels in parallel. The length must be chosen for the maximal data length of all used IO-Link Devices on one IO-Link Master. The chosen data length will be used for all IO-Link Master ports in parallel for the input and output data size. This provides simple and constant data offsets in the input data stream with reduced input/output data amounts.

► Configured extended IO-Link status data

This block contains IO-Link communication states, parameter storage states and the IDs of the connected IO-Link Devices.

► Configured IO-Link event data

This block can contain up to three IO-Link Device event data sets.

For configuring the input/output data, the following EtherNet/IP assembly couples are available: (Connection = CONN, Assembly = ASSY)

Conn No.	Input ASSY	Input data	Output ASSY
1	101	Status data of IO-Link Master (without IO-Link Device and opt. data)	100 (0 Byte IO-L)
2	103	Status data IO-L master + 4 Byte IO-L device per port	102 (4 Byte IO-L)
5	105	Status data IO-L master + 8 Byte IO-L device per port	104 (8 Byte IO-L)
8	107	Status data IO-L master + 16 Byte IO-L device per port	106 (16 Byte IO-L)
11	109	Status data IO-L master + 32 Byte IO-L device per port	108 (32 Byte IO-L)
3	111	Status data IO-L master + 4 Byte IO-L per port + extend. IO-Link state	102 (4 Byte IO-L)
6	113	Status data IO-L master + 8 Byte IO-L per port + extend. IO-Link state	104 (8 Byte IO-L)
9	115	Status data IO-L master + 16 Byte IO-L per port + extend. IO-Link state	106 (16 Byte IO-L)
12	117	Status data IO-L master + 32 Byte IO-L per port + extend. IO-Link state	108 (32 Byte IO-L)
4	119	Status data IO-L master + 4 Byte IO-L per port + extend. IO-Link state + IO-L events	102 (4 Byte IO-L)
7	121	Status data IO-L master + 8 Byte IO-L per port + extend. IO-Link state + IO-L events	104 (8 Byte IO-L)
10	123	Status data IO-L master + 16 Byte IO-L per port + extend. IO-Link state + IO-L events	106 (16 Byte IO-L)
13	125	Status data IO-L master + 32 Byte IO-L per port + extend. IO-Link state + IO-L events	108 (32 Byte IO-L)

Table 20: Assembly couples input and output

Size of output data The amount of consumer data (output data) is variable. The first block of data within the output data is always the control data block of the IO-Link Master. This block contains the digital output control bits of the I/O ports.

The variable amount of output data depends on the

► Configured IO-Link input/output data size

The IO-Link output data can be chosen in length of 4, 8, 16 or 32 bytes for all IO-Link channels in parallel. The length must be chosen for the maximal data length of all used IO-Link Devices on one IO-Link Master. The chosen data length will be used for all IO-Link Master ports in parallel for the input and output data size. This provides simple and constant data offsets in the data stream.

For configuring the input/output data, the following EtherNet/IP assembly couples are available: (Connection = CONN, Assembly = ASSY)

Conn No.	Output ASSY	Output data	Input ASSY
1	100	Status data of IO-Link Master (without IO-Link Device and opt. data)	101 (0 Byte IO-L)
2	102	4 byte IO-L master control data + 4 Byte IO-L device per port	103 (4 Byte IO-L)
3	102	4 byte IO-L master control data + 4 Byte IO-L device per port	111 (4 Byte IO-L + state)
4	102	4 byte IO-L master control data + 4 Byte IO-L device per port	119 (4 Byte IO-L + state + event)
5	104	4 byte IO-L master control data + 8 Byte IO-L device per port	105 (8 Byte IO-L)
6	104	4 byte IO-L master control data + 8 Byte IO-L device per port	113 (8 Byte IO-L + state)
7	104	4 byte IO-L master control data + 8 Byte IO-L device per port	121 (8 Byte IO-L + state + event)
8	106	4 byte IO-L master control data + 16 Byte IO-L device per port	107 (16 Byte IO-L)

Conn No.	Output ASSY	Output data	Input ASSY
9	106	4 byte IO-L master control data + 16 Byte IO-L device per port	115 (16 Byte IO-L + state)
10	106	4 byte IO-L master control data + 16 Byte IO-L device per port	123 (16 Byte IO-L + state + event)
11	108	4 byte IO-L master control data + 32 Byte IO-L device per port	109 (32 Byte IO-L)
12	108	4 byte IO-L master control data + 32 Byte IO-L device per port	117 (32 Byte IO-L + state)
13	108	4 byte IO-L master control data + 32 Byte IO-L device per port	125 (32 Byte IO-L + state + event)

Table 21: Assembly couples output and input

7.2 Listen Only Connections

Listen Only connections are available in multicast direction. For configuring the input data as Listen Only connection the following EtherNet/IP assemblies are available: (Connection = CONN, Assembly = ASSY)

CONN No.	Input ASSY	Input data	Output ASSY
14	100	Status data of IO-Link Master (without IO-Link Device and opt. data)	-
15	102	Status data IO-L master + 4 Byte IO-L device per port	-
16	102	Status data IO-L master + 8 Byte IO-L device per port	-
17	102	Status data IO-L master + 16 Byte IO-L device per port	-
18	104	Status data IO-L master + 32 Byte IO-L device per port	-

Table 22: Listen only connections

8 Bit assignment

With the input data, actual values are specified with the output data target values.

8.1 Status data of IO-Link Master (inputs)

Status data	Description
Byte 0	Status of digital inputs, port 1 – 4 (mapping mode 1, default)
Byte 1	Status of digital inputs, port 5 – 8 (mapping mode 1, default)
Byte 2	Status of IO-Link communication
Byte 3	Status of IO-Link process data validity
Byte 4	Status of module diagnostic (byte 0)
Byte 5	Status of module diagnostic (byte 1)
Byte 6	Status of sensor supply diagnostic, port 1 – 8
Byte 7	Reserved
Byte 8	Status of digital output diagnostic for channel A, port 1 – 8
Byte 9	Status of digital output diagnostic for channel B, port 5 – 8
Byte 10	Status of IO-Link Device diagnostic from type error, port 1 – 8
Byte 11	Status of IO-Link Device diagnostic from type warning, port 1 – 8
Byte 12	Status of IO-Link Device diagnostic from type notification, port 1 – 8
Byte 13	Reserved

Table 23: Status data of IO-Link Master

Refer to the following chapter for detailed information about input status data.

8.1.1 Status of digital inputs (mapping 1, default)

If mapping mode 1 was selected in the device configuration, the digital input data of the module are transferred as follows.

Byte 0 Digital input status of ports 1 - 4								
Bit	7	6	5	4	3	2	1	0
Port	X4	X4	X3	X3	X2	X2	X1	X1
Pin	2	4	2	4	2	4	2	4
Channel	4B	4A	3B	3A	2B	2A	1B	1A

Table 24: Byte 0, Status of digital inputs, mapping 1

Byte 1 Digital input status of ports 5 - 8								
Bit	7	6	5	4	3	2	1	0
Port	X4	X4	X3	X3	X2	X2	X1	X1
Pin	2	4	2	4	2	4	2	4
Channel	8B	8A	7B	7A	6B	6A	5B	5A

Table 25: Byte 1, Status of digital inputs, mapping 1

The data in the cells highlighted in blue are available for LioN-P 60 devices only. They are representing the physical output status.

8.1.2 Status of digital inputs (mapping 2)

If mapping mode 2 was selected in the device configuration, the digital input data of the module are transferred as follows.

Byte 0 Digital input status channel A of ports 1 - 8								
Bit	7	6	5	4	3	2	1	0
Port	X8	X7	X6	X5	X4	X3	X2	X1
Pin	4	4	4	4	4	4	4	4
Channel	8A	7A	6A	5A	4A	3A	2A	1A

Table 26: Byte 0, Status of digital inputs, mapping 2

Byte 1 Digital input status channel B of ports 1 - 8								
Bit	7	6	5	4	3	2	1	0
Port	X8	X7	X6	X5	X4	X3	X2	X1
Pin	2	2	2	2	2	2	2	2
Channel	8B	7B	6B	5B	4B	3B	2B	1B

Table 27: Byte 1, Status of digital inputs, mapping 2

The data in the cells highlighted in blue are available for LioN-P 60 devices only. They are representing the physical output status.

8.1.3 Status of IO-Link communication

The IOL-COM state indicates whether the port has established a communication with the IO-Link Device.

Byte 2 IOL-COM state								
Bit	7	6	5	4	3	2	1	0
Port	X8	X7	X6	X5	X4	X3	X2	X1
Pin	4	4	4	4	4	4	4	4
Channel	8A	7A	6A	5A	4A	3A	2A	1A

Table 28: Byte 2, IOL-COM state

8.1.4 Status of IO-Link process data validity

The IOL-PD valid information indicates whether the IO-Link process data of the corresponding port are valid.

Byte 2 IOL-PD valid								
Bit	7	6	5	4	3	2	1	0
Port	X8	X7	X6	X5	X4	X3	X2	X1
Pin	4	4	4	4	4	4	4	4
Channel	8A	7A	6A	5A	4A	3A	2A	1A

Table 29: Byte 3, IOL-PD valid

8.1.5 Status of module diagnostic

This data delivers the collective information of the available module diagnosis.

Input	Bit 7	Bit 6	Bit 5	Bit 4	Bit 3	Bit 2	Bit 1	Bit 0
Byte 4	0	MI-FMA	MI-VAL	MI-SCB	MI-SCA	MI-SCS	MI-LVA	MI-LVS
Byte 5	0	0	0	0	0	IOL-DN	IOL-DW	IOL-DE

Table 30: Byte 4 - 5, Status of module diagnostic

- ▶ MI-LVS: Module information – system/sensor power supply low voltage
- ▶ MI-LVA: Module information – auxiliary power supply low voltage
- ▶ MI-SCS: Module information – sensor short-circuit
- ▶ MI-SCA: Module information – actuator short-circuit channel A
- ▶ MI-SCB: Module information – actuator short-circuit channel B
- ▶ MI-VAL: Module information – IO-Link validation error
- ▶ MI-FMA: Module information – Forcemode active
- ▶ MI-DE: Module information – IO-Link Device error
- ▶ MI-DW: Module information – IO-Link Device warning
- ▶ MI-DN: Module information – IO-Link Device notification

8.1.6 Status of sensor supply diagnostic

This data delivers the status information per port of the sensor supply diagnostic (Pin 1 of X1 – X8).

Input	Bit 7	Bit 6	Bit 5	Bit 4	Bit 3	Bit 2	Bit 1	Bit 0
Byte 6	SCS-X8	SCS-X7	SCS-X6	SCS-X5	SCS-X4	SCS-X3	SCS-X2	SCS-X1

Table 31: Byte 6, Status of sensor supply diagnostic

- ▶ SCS-X1 ... SCS-X8: Sensor short-circuit at slot X1 to X8

8.1.7 Reserved (byte 7)

8.1.8 Status of digital output diagnostic

This data delivers the information per port of the digital output diagnosis for channel A and channel B. For LioN-P 60 modules the channel B information is also available if the port is configured as auxiliary supply.

Input	Bit 7	Bit 6	Bit 5	Bit 4	Bit 3	Bit 2	Bit 1	Bit 0
Byte 8	CE-X8A	CE-X7A	CE-X6A	CE-X5A	CE-X4A	CE-X3A	CE-X2A	CE-X1A
Byte 9	CE-X8B	CE-X7B	CE-X6B	CE-X5B	0	0	0	0

Table 32: Byte 8 - 9, Status of digital output diagnostic

► CE-X1A ... CE-X8A:

Channel error, channel A (Pin 4) of slots X1 to X8

► CE-X5B ... CE-X8B:

Channel error, channel B (Pin 2) of slots X1 to X8

8.1.9 Status of module diagnostic

This data delivers the information per port if an IO-Link Device has sent an **error**, **warning** or **notification** message.

Input	Bit 7	Bit 6	Bit 5	Bit 4	Bit 3	Bit 2	Bit 1	Bit 0
Byte 10	DE-X8A	DE-X7A	DE-X6A	DE-X5A	DE-X4A	DE-X3A	DE-X2A	DE-X1A
Byte 11	DW-X8A	DW-X7A	DW-X6A	DW-X5A	DW-X4A	DW-X3A	DW-X2A	DW-X1A
Byte 12	DN-X8A	DN-X7A	DN-X6A	DN-X5A	DN-X4A	DN-X3A	DN-X2A	DN-X1A
Byte 13	VAL-X8A	VAL-X7A	VAL-X6A	VAL-X5A	VAL-X4A	VAL-X3A	VAL-X2A	VAL-X1A

Table 33: Byte 10 - 13, Status of IO-Link Device diagnostic

► DE-X1A ... DE-X8A:

IO-Link Device **error** message, channel A (Pin 4, C/Q) of slots X1 to X8

► DW-X1A ... DW-X8A:

IO-Link Device **warning** message, channel A (Pin 4, C/Q) of slots X1 to X8

▶ DN-X1A ... DN-X8A:

IO-Link Device **notification** message, channel A (Pin 4, C/Q) of slots X1 to X8

▶ VAL-X1A ... VAL-X8A:

IO-Link Master **validation error**, channel A (Pin 4, C/Q) of slots X1 to X8

8.2 IO-Link Device input data

Depending on the chosen input assembly

- ▶ 103: 4 byte IO-Link input
- ▶ 105: 8 byte IO-Link input
- ▶ 107: 16 byte IO-Link input
- ▶ 109: 32 byte IO-Link input

- ▶ 111: 4 byte IO-L input + 8 byte extended IO-Link status
- ▶ 113: 8 byte IO-L input + 8 byte extended IO-Link status
- ▶ 115: 16 byte IO-L input + 8 byte extended IO-Link status
- ▶ 117: 32 byte IO-L input + 8 byte extended IO-Link status

- ▶ 119: 4 byte IO-L input + 8 byte ext. IO-L status + 12 byte IO-Link event
- ▶ 121: 8 byte IO-L input + 8 byte ext. IO-L status + 12 byte IO-Link event
- ▶ 123: 16 byte IO-L input + 8 byte ext. IO-L status + 12 byte IO-Link event
- ▶ 125: 32 byte IO-L input + 8 byte ext. IO-L status + 12 byte IO-Link event

data will be added for every IO-Link port to the producer data at address offset 14. The received IO-Link Device input data will be transferred to the EtherNet/IP controller without byte swapping.

8.2.1 IO-Link data for 4 byte input, assembly 103

The assembly 103 provides 4 byte IO-Link input data for every IO-Link port with the following mapping:

Input	Port	Description
Byte 14 - 17	X1	Byte 0 of IO-Link input data - Byte 3 of IO-Link input data
Byte 18 - 21	X2	Byte 0 of IO-Link input data - Byte 3 of IO-Link input data
Byte 22 - 25	X3	Byte 0 of IO-Link input data - Byte 3 of IO-Link input data
Byte 26 - 29	X4	Byte 0 of IO-Link input data - Byte 3 of IO-Link input data
Byte 30 - 33	X5	Byte 0 of IO-Link input data - Byte 3 of IO-Link input data
Byte 34 - 37	X6	Byte 0 of IO-Link input data - Byte 3 of IO-Link input data
Byte 38 - 41	X7	Byte 0 of IO-Link input data - Byte 3 of IO-Link input data
Byte 42 - 45	X8	Byte 0 of IO-Link input data - Byte 3 of IO-Link input data

Table 34: Byte 14 - 45, Input data for input assembly 103

The 4 byte input data per port are zero, if no IO-Link Device is connected to the appropriate port.

8.2.2 IO-Link data for 8 byte input, assembly 105

The assembly 105 provides 8 byte IO-Link input data for every IO-Link port with the following mapping:

Input	Port	Description
Byte 14 - 21	X1	Byte 0 of IO-Link input data - Byte 7 of IO-Link input data
Byte 22 - 29	X2	Byte 0 of IO-Link input data - Byte 7 of IO-Link input data
Byte 30 - 37	X3	Byte 0 of IO-Link input data - Byte 7 of IO-Link input data
Byte 38 - 45	X4	Byte 0 of IO-Link input data - Byte 7 of IO-Link input data
Byte 46 - 53	X5	Byte 0 of IO-Link input data - Byte 7 of IO-Link input data
Byte 54 - 61	X6	Byte 0 of IO-Link input data - Byte 7 of IO-Link input data
Byte 62 - 69	X7	Byte 0 of IO-Link input data - Byte 7 of IO-Link input data
Byte 70 - 77	X8	Byte 0 of IO-Link input data - Byte 7 of IO-Link input data

Table 35: Byte 14 - 77, Input data for input assembly 105

The 8 byte input data per port are zero, if no IO-Link Device is connected to the appropriate port.

8.2.3 IO-Link data for 16 byte input, assembly 107

The assembly 107 provides 8 byte IO-Link input data for every IO-Link port with the following mapping:

Input	Port	Description
Byte 14 - 29	X1	Byte 0 of IO-Link input data - Byte 15 of IO-Link input data
Byte 30 - 45	X2	Byte 0 of IO-Link input data - Byte 15 of IO-Link input data
Byte 46 - 61	X3	Byte 0 of IO-Link input data - Byte 15 of IO-Link input data
Byte 62 - 77	X4	Byte 0 of IO-Link input data - Byte 15 of IO-Link input data
Byte 78 - 93	X5	Byte 0 of IO-Link input data - Byte 15 of IO-Link input data
Byte 94 - 109	X6	Byte 0 of IO-Link input data - Byte 15 of IO-Link input data
Byte 110 - 125	X7	Byte 0 of IO-Link input data - Byte 15 of IO-Link input data
Byte 126 - 141	X8	Byte 0 of IO-Link input data - Byte 15 of IO-Link input data

Table 36: Byte 14 - 141, Input data for input assembly 107

The 16 byte input data per port are zero, if no IO-Link Device is connected to the appropriate port.

8.2.4 IO-Link data for 32 byte input, assembly 109

The assembly 109 provides 32 byte IO-Link input data for every IO-Link port with the following mapping:

Input	Port	Description
Byte 14 - 45	X1	Byte 0 of IO-Link input data - Byte 31 of IO-Link input data
Byte 46 - 77	X2	Byte 0 of IO-Link input data - Byte 31 of IO-Link input data
Byte 78 - 109	X3	Byte 0 of IO-Link input data - Byte 31 of IO-Link input data
Byte 110 - 141	X4	Byte 0 of IO-Link input data - Byte 31 of IO-Link input data
Byte 142 - 173	X5	Byte 0 of IO-Link input data - Byte 31 of IO-Link input data
Byte 174 - 205	X6	Byte 0 of IO-Link input data - Byte 31 of IO-Link input data
Byte 206 - 237	X7	Byte 0 of IO-Link input data - Byte 31 of IO-Link input data
Byte 238 - 269	X8	Byte 0 of IO-Link input data - Byte 31 of IO-Link input data

The 32 byte input data per port are zero, if no IO-Link Device is connected to the appropriate port.

8.3 IO-Link input & extended IO-Link status data

Depending on the chosen input assembly

- ▶ 111: 4 byte IO-L input + 8 byte extended IO-Link status
- ▶ 113: 8 byte IO-L input + 8 byte extended IO-Link status
- ▶ 115: 16 byte IO-L input + 8 byte extended IO-Link status
- ▶ 117: 32 byte IO-L input + 8 byte extended IO-Link status

data will be added for every IO-Link port to the producer data at address offset 14. The received IO-Link device input data will be transferred to the EtherNet/IP controller without byte swapping. The extended IO-Link status data are defined as follows:

Byte	Bit	Description
0	7	Reserved
	6	Reserved
	5	Reserved
	4	Reserved
	3	Reserved
	2	Reserved
	1	1 = Communication with IO-Link Device available
	0	1 = Port in IO-Link mode configured
1	7	Reserved
	6	Reserved
	5	Reserved
	4	Reserved
	3	1 = IO-Link Device detected and serial number identical
	2	1 = Detected IO-Link Device incompatible (VendorID or DeviceID)
	1	1 = Parameter storage error
	0	1 = Direct parameter page not plausible
2	Vendor ID (LSB)	
3	Vendor ID (MSB)	
4	Device ID (LSB)	
5	Device ID	
6	Device ID (MSB)	
7	Reserved	

Table 37: Byte 0 - 7, Extended IO-Link status data

8.3.1 IO-Link 4 byte input & ext. status, assembly 111

The assembly 111 provides 4 byte IO-Link input and 8 byte extended IO-Link status data for every IO-Link port with the following mapping:

Input	Port	Description
Byte 14 - 17	X1	Byte 0 of IO-Link input data - Byte 3 of IO-Link input data
Byte 18 - 25	X1	Byte 0 of ext. IO-L status - Byte 7 of ext. IO-L status
Byte 26 - 29	X2	Byte 0 of IO-Link input data - Byte 3 of IO-Link input data
Byte 30 - 33	X2	Byte 0 of ext. IO-L status - Byte 7 of ext. IO-L status
Byte 34 - 41	X3	Byte 0 of IO-Link input data - Byte 3 of IO-Link input data
Byte 42 - 49	X3	Byte 0 of ext. IO-L status - Byte 7 of ext. IO-L status
Byte 50 - 53	X4	Byte 0 of IO-Link input data - Byte 3 of IO-Link input data
Byte 54 - 61	X4	Byte 0 of ext. IO-L status - Byte 7 of ext. IO-L status
Byte 62 - 65	X5	Byte 0 of IO-Link input data - Byte 3 of IO-Link input data
Byte 66 - 73	X5	Byte 0 of ext. IO-L status - Byte 7 of ext. IO-L status
Byte 74 - 77	X6	Byte 0 of IO-Link input data - Byte 3 of IO-Link input data
Byte 78 - 85	X6	Byte 0 of ext. IO-L status - Byte 7 of ext. IO-L status
Byte 86 - 89	X7	Byte 0 of IO-Link input data - Byte 3 of IO-Link input data
Byte 90 - 97	X7	Byte 0 of ext. IO-L status - Byte 7 of ext. IO-L status
Byte 98 - 101	X8	Byte 0 of IO-Link input data - Byte 3 of IO-Link input data
Byte 102 - 109	X8	Byte 0 of ext. IO-L status - Byte 7 of ext. IO-L status

Table 38: Byte 14 - 109, Input data for input assembly 111

The 4 byte input and extended IO-Link status data per port are zero, if no IO-Link Device is connected to the appropriate port.

8.3.2 IO-Link 8 byte input & ext. status, assembly 113

The assembly 113 provides 8 byte IO-Link input and 8 byte extended IO-Link status data for every IO-Link port with the following mapping:

Input	Port	Description
Byte 14 - 21	X1	Byte 0 of IO-Link input data - Byte 7 of IO-Link input data
Byte 22 - 29	X1	Byte 0 of ext. IO-L status - Byte 7 of ext. IO-L status
Byte 30 - 37	X2	Byte 0 of IO-Link input data - Byte 7 of IO-Link input data
Byte 38 - 45	X2	Byte 0 of ext. IO-L status - Byte 7 of ext. IO-L status
Byte 46 - 53	X3	Byte 0 of IO-Link input data - Byte 7 of IO-Link input data
Byte 54 - 61	X3	Byte 0 of ext. IO-L status - Byte 7 of ext. IO-L status
Byte 62 - 69	X4	Byte 0 of IO-Link input data - Byte 7 of IO-Link input data
Byte 70 - 77	X4	Byte 0 of ext. IO-L status - Byte 7 of ext. IO-L status
Byte 78 - 85	X5	Byte 0 of IO-Link input data - Byte 7 of IO-Link input data
Byte 86 - 93	X5	Byte 0 of ext. IO-L status - Byte 7 of ext. IO-L status
Byte 94 - 101	X6	Byte 0 of IO-Link input data - Byte 7 of IO-Link input data
Byte 102 - 109	X6	Byte 0 of ext. IO-L status - Byte 7 of ext. IO-L status
Byte 110 - 117	X7	Byte 0 of IO-Link input data - Byte 7 of IO-Link input data
Byte 118 - 125	X7	Byte 0 of ext. IO-L status - Byte 7 of ext. IO-L status
Byte 126 - 133	X8	Byte 0 of IO-Link input data - Byte 7 of IO-Link input data
Byte 134 - 141	X8	Byte 0 of ext. IO-L status - Byte 7 of ext. IO-L status

Table 39: Byte 14 - 141, Input data for input assembly 113

The 8 byte input and extended IO-Link status data per port are zero, if no IO-Link Device is connected to the appropriate port.

8.3.3 IO-Link 16 byte input & ext. status, assembly 115

The assembly 115 provides 16 byte IO-Link input and 8 byte extended IO-Link status data for every IO-Link port with the following mapping:

Input	Port	Description
Byte 14 - 29	X1	Byte 0 of IO-Link input data - Byte 15 of IO-Link input data
Byte 30 - 37	X1	Byte 0 of ext. IO-L status - Byte 7 of ext. IO-L status
Byte 38 - 53	X2	Byte 0 of IO-Link input data - Byte 15 of IO-Link input data
Byte 54 - 61	X2	Byte 0 of ext. IO-L status - Byte 7 of ext. IO-L status
Byte 62 - 77	X3	Byte 0 of IO-Link input data - Byte 15 of IO-Link input data
Byte 78 - 85	X3	Byte 0 of ext. IO-L status - Byte 7 of ext. IO-L status
Byte 86 - 101	X4	Byte 0 of IO-Link input data - Byte 15 of IO-Link input data
Byte 102 - 109	X4	Byte 0 of ext. IO-L status - Byte 7 of ext. IO-L status
Byte 110 - 125	X5	Byte 0 of IO-Link input data - Byte 15 of IO-Link input data
Byte 126 - 133	X5	Byte 0 of ext. IO-L status - Byte 7 of ext. IO-L status
Byte 134 - 149	X6	Byte 0 of IO-Link input data - Byte 15 of IO-Link input data
Byte 150 - 157	X6	Byte 0 of ext. IO-L status - Byte 7 of ext. IO-L status
Byte 158 - 173	X7	Byte 0 of IO-Link input data - Byte 15 of IO-Link input data
Byte 174 - 181	X7	Byte 0 of ext. IO-L status - Byte 7 of ext. IO-L status
Byte 182 -197	X8	Byte 0 of IO-Link input data - Byte 15 of IO-Link input data
Byte 198 - 205	X8	Byte 0 of ext. IO-L status - Byte 7 of ext. IO-L status

Table 40: Byte 14 - 205, Input data for input assembly 115

The 16 byte input and extended IO-Link status data per port are zero, if no IO-Link Device is connected to the appropriate port.

8.3.4 IO-Link 32 byte input & ext. status, assembly 117

The assembly 117 provides 32 byte IO-Link input and 8 byte extended IO-Link status data for every IO-Link port with the following mapping:

Input	Port	Description
Byte 14 - 45	X1	Byte 0 of IO-Link input data - Byte 31 of IO-Link input data
Byte 46 - 53	X1	Byte 0 of ext. IO-L status - Byte 7 of ext. IO-L status
Byte 54 - 85	X2	Byte 0 of IO-Link input data - Byte 31 of IO-Link input data
Byte 86 - 93	X2	Byte 0 of ext. IO-L status - Byte 7 of ext. IO-L status
Byte 94 - 125	X3	Byte 0 of IO-Link input data - Byte 31 of IO-Link input data
Byte 126 - 133	X3	Byte 0 of ext. IO-L status - Byte 7 of ext. IO-L status
Byte 134 - 165	X4	Byte 0 of IO-Link input data - Byte 31 of IO-Link input data
Byte 166 - 173	X4	Byte 0 of ext. IO-L status - Byte 7 of ext. IO-L status
Byte 174 - 205	X5	Byte 0 of IO-Link input data - Byte 31 of IO-Link input data
Byte 206 - 213	X5	Byte 0 of ext. IO-L status - Byte 7 of ext. IO-L status
Byte 214 - 245	X6	Byte 0 of IO-Link input data - Byte 31 of IO-Link input data
Byte 246 - 253	X6	Byte 0 of ext. IO-L status - Byte 7 of ext. IO-L status
Byte 254 - 285	X7	Byte 0 of IO-Link input data - Byte 31 of IO-Link input data
Byte 286 - 293	X7	Byte 0 of ext. IO-L status - Byte 7 of ext. IO-L status
Byte 294 - 325	X8	Byte 0 of IO-Link input data - Byte 31 of IO-Link input data
Byte 326 - 333	X8	Byte 0 of ext. IO-L status - Byte 7 of ext. IO-L status

Table 41: Byte 14 - 333, Input data for input assembly 117

The 32 byte input and extended IO-Link status data per port are zero, if no IO-Link Device is connected to the appropriate port.

8.4 IO-Link input & ext. IO-Link status & IO-Link event

Depending on the chosen input assembly

- ▶ 119: 4 byte IO-L input + 8 byte ext. IO-L status + IO-Link event data
- ▶ 121: 8 byte IO-L input + 8 byte ext. IO-L status + IO-Link event data
- ▶ 123: 16 byte IO-L input + 8 byte ext. IO-L status + IO-Link event data
- ▶ 125: 32 byte IO-L input + 8 byte ext. IO-L status + IO-Link event data

data will be added for every IO-Link port to the producer data at address offset 14. The received IO-Link device input data will be transferred to the EtherNet/IP controller without byte swapping.

The extended IO-Link status data are defined as follows:

Byte	Bit	Description
0	1	Event Qualifier
1	1	Event Code 1 (LSB)
2	1	Event Code 2 (MSB)
3	1	Reserved
4	2	Event Qualifier
5	2	Event Code 1 (LSB)
6	2	Event Code 2 (MSB)
7	2	Reserved
8	3	Event Qualifier
9	3	Event Code 1 (LSB)
10	3	Event Code 2 (MSB)
11	3	Reserved

Table 42: IO-Link event block

This data block can contain up to three event messages of the connected IO-Link Device. Event 1 shows always the latest event messages, former event messages will be shifted to event block two or three. The event data will be cleared only after a power cycle of the IO-Link Master.

8.4.1 Event Qualifier

	Mode		Type		Res.		Instance	
Bit	7	6	5	4	3	2	1	0

Table 43: Event qualifier

► Event Qualifier Instance:

Value	Definition
0	Unknown
1	Phy.
2	DL
3	AL
4	Application
5 ... 7	reserved

Table 44: Event qualifier instance

► Event Qualifier Res.:

This bit is reserved and must be set to 0.

► Event Qualifier Type:

Value	Definition
0	Reserved
1	Information
2	Warning
3	Error

Table 45: Event qualifier type

► Event Qualifier Mode:

Value	Definition
0	Reserved
1	Event single shot
2	Event disappears
3	Event appears

*Table 46: Event qualifier mode***8.4.2 Event Code 1 and 2**

Diagnostic code reported by the IO-Link Device. Use the IO-Link Device documentation to interpret the error message.

8.4.3 IO-L 4 byte & status & event data, assembly 119

The assembly 119 provides 4 byte IO-Link input, 8 byte extended IO-Link status and 8 byte IO-Link event data for every IO-Link port with the following mapping:

Input	Port	Description
Byte 14 - 17	X1	Byte 0 of IO-Link input data - Byte 3 of IO-Link input data
Byte 18 - 25	X1	Byte 0 of ext. IO-L status - Byte 7 of ext. IO-L status
Byte 26 - 37	X1	Byte 0 of IO-L event data - Byte 11 of IO-L event data
Byte 38 - 41	X2	Byte 0 of IO-Link input data - Byte 3 of IO-Link input data
Byte 42 - 49	X2	Byte 0 of ext. IO-L status - Byte 7 of ext. IO-L status
Byte 50 - 61	X2	Byte 0 of IO-L event data - Byte 11 of IO-L event data
Byte 62 - 65	X3	Byte 0 of IO-Link input data - Byte 3 of IO-Link input data
Byte 66 - 73	X3	Byte 0 of ext. IO-L status - Byte 7 of ext. IO-L status
Byte 74 - 85	X3	Byte 0 of IO-L event data - Byte 11 of IO-L event data
Byte 86 - 89	X4	Byte 0 of IO-Link input data - Byte 3 of IO-Link input data
Byte 90 - 97	X4	Byte 0 of ext. IO-L status - Byte 7 of ext. IO-L status
Byte 98 - 109	X4	Byte 0 of IO-L event data - Byte 11 of IO-L event data
Byte 110 - 113	X5	Byte 0 of IO-Link input data - Byte 3 of IO-Link input data
Byte 114 - 121	X5	Byte 0 of ext. IO-L status - Byte 7 of ext. IO-L status
Byte 122 - 133	X5	Byte 0 of IO-L event data - Byte 11 of IO-L event data
Byte 134 - 137	X6	Byte 0 of IO-Link input data - Byte 3 of IO-Link input data
Byte 138 - 145	X6	Byte 0 of ext. IO-L status - Byte 7 of ext. IO-L status
Byte 146 - 157	X6	Byte 0 of IO-L event data - Byte 11 of IO-L event data
Byte 158 - 161	X7	Byte 0 of IO-Link input data - Byte 3 of IO-Link input data
Byte 162 - 169	X7	Byte 0 of ext. IO-L status - Byte 7 of ext. IO-L status
Byte 170 - 181	X7	Byte 0 of IO-L event data - Byte 11 of IO-L event data
Byte 182 - 185	X8	Byte 0 of IO-Link input data - Byte 3 of IO-Link input data
Byte 186 - 193	X8	Byte 0 of ext. IO-L status - Byte 7 of ext. IO-L status

Input	Port	Description
Byte 194 - 205	X8	Byte 0 of IO-L event data - Byte 11 of IO-L event data

Table 47: Byte 14 - 205, Input data for input assembly 119

The 4 byte input, extended IO-Link status and IO-Link event data per port are zero, if no IO-Link Device is connected to the appropriate port.

8.4.4 IO-L 8 byte & status & event data, assembly 121

The assembly 121 provides 8 byte IO-Link input, 8 byte extended IO-Link status and 8 byte IO-Link event data for every IO-Link port with the following mapping:

Input	Port	Description
Byte 14 - 21	X1	Byte 0 of IO-Link input data - Byte 7 of IO-Link input data
Byte 22 - 29	X1	Byte 0 of ext. IO-L status - Byte 7 of ext. IO-L status
Byte 30 - 41	X1	Byte 0 of IO-L event data - Byte 11 of IO-L event data
Byte 42 - 49	X2	Byte 0 of IO-Link input data - Byte 7 of IO-Link input data
Byte 50 - 57	X2	Byte 0 of ext. IO-L status - Byte 7 of ext. IO-L status
Byte 58 - 69	X2	Byte 0 of IO-L event data - Byte 11 of IO-L event data
Byte 70 - 77	X3	Byte 0 of IO-Link input data - Byte 7 of IO-Link input data
Byte 78 - 85	X3	Byte 0 of ext. IO-L status - Byte 7 of ext. IO-L status
Byte 86 - 97	X3	Byte 0 of IO-L event data - Byte 11 of IO-L event data
Byte 98 - 105	X4	Byte 0 of IO-Link input data - Byte 7 of IO-Link input data
Byte 106 - 113	X4	Byte 0 of ext. IO-L status - Byte 7 of ext. IO-L status
Byte 114 - 125	X4	Byte 0 of IO-L event data - Byte 11 of IO-L event data
Byte 126 - 133	X5	Byte 0 of IO-Link input data - Byte 7 of IO-Link input data
Byte 134 - 141	X5	Byte 0 of ext. IO-L status - Byte 7 of ext. IO-L status
Byte 142 - 153	X5	Byte 0 of IO-L event data - Byte 11 of IO-L event data
Byte 154 - 161	X6	Byte 0 of IO-Link input data - Byte 7 of IO-Link input data
Byte 162 - 169	X6	Byte 0 of ext. IO-L status - Byte 7 of ext. IO-L status
Byte 170 - 181	X6	Byte 0 of IO-L event data - Byte 11 of IO-L event data
Byte 182 - 189	X7	Byte 0 of IO-Link input data - Byte 7 of IO-Link input data
Byte 190 - 197	X7	Byte 0 of ext. IO-L status - Byte 7 of ext. IO-L status
Byte 198 - 209	X7	Byte 0 of IO-L event data - Byte 11 of IO-L event data
Byte 210 - 217	X8	Byte 0 of IO-Link input data - Byte 7 of IO-Link input data
Byte 218 - 225	X8	Byte 0 of ext. IO-L status - Byte 7 of ext. IO-L status

Input	Port	Description
Byte 226 - 237	X8	Byte 0 of IO-L event data - Byte 11 of IO-L event data

Table 48: Byte 14 - 237, Input data for input assembly 121

The 8 byte input, extended IO-Link status and IO-Link event data per port are zero, if no IO-Link Device is connected to the appropriate port.

8.4.5 IO-L 16 byte & status & event data, assembly 123

The assembly 123 provides 16 byte IO-Link input, 8 byte extended IO-Link status and 8 byte IO-Link event data for every IO-Link port with the following mapping:

Input	Port	Description
Byte 14 - 29	X1	Byte 0 of IO-Link input data - Byte 15 of IO-Link input data
Byte 30 - 37	X1	Byte 0 of ext. IO-L status - Byte 7 of ext. IO-L status
Byte 38 - 49	X1	Byte 0 of IO-L event data - Byte 11 of IO-L event data
Byte 50 - 65	X2	Byte 0 of IO-Link input data - Byte 15 of IO-Link input data
Byte 66 - 73	X2	Byte 0 of ext. IO-L status - Byte 7 of ext. IO-L status
Byte 74 - 85	X2	Byte 0 of IO-L event data - Byte 11 of IO-L event data
Byte 86 - 101	X3	Byte 0 of IO-Link input data - Byte 15 of IO-Link input data
Byte 102 - 109	X3	Byte 0 of ext. IO-L status - Byte 7 of ext. IO-L status
Byte 110 - 121	X3	Byte 0 of IO-L event data - Byte 11 of IO-L event data
Byte 122 - 137	X4	Byte 0 of IO-Link input data - Byte 15 of IO-Link input data
Byte 138 - 145	X4	Byte 0 of ext. IO-L status - Byte 7 of ext. IO-L status
Byte 146 - 157	X4	Byte 0 of IO-L event data - Byte 11 of IO-L event data
Byte 158 - 173	X5	Byte 0 of IO-Link input data - Byte 15 of IO-Link input data
Byte 174 - 181	X5	Byte 0 of ext. IO-L status - Byte 7 of ext. IO-L status
Byte 182 - 193	X5	Byte 0 of IO-L event data - Byte 11 of IO-L event data
Byte 194 - 209	X6	Byte 0 of IO-Link input data - Byte 15 of IO-Link input data
Byte 210 - 217	X6	Byte 0 of ext. IO-L status - Byte 7 of ext. IO-L status
Byte 218 - 229	X6	Byte 0 of IO-L event data - Byte 11 of IO-L event data
Byte 230 - 245	X7	Byte 0 of IO-Link input data - Byte 15 of IO-Link input data
Byte 246 - 253	X7	Byte 0 of ext. IO-L status - Byte 7 of ext. IO-L status
Byte 254 - 265	X7	Byte 0 of IO-L event data - Byte 11 of IO-L event data
Byte 266 - 281	X8	Byte 0 of IO-Link input data - Byte 15 of IO-Link input data
Byte 282 - 289	X8	Byte 0 of ext. IO-L status - Byte 7 of ext. IO-L status

Input	Port	Description
Byte 290 - 301	X8	Byte 0 of IO-L event data - Byte 11 of IO-L event data

Table 49: Byte 14 - 301, Input data for input assembly 123

The 16 byte input, extended IO-Link status and IO-Link event data per port are zero, if no IO-Link Device is connected to the appropriate port.

8.4.6 IO-L 32 byte & status & event data, assembly 125

The assembly 125 provides 32 byte IO-Link input, 8 byte extended IO-Link status and 8 byte IO-Link event data for every IO-Link port with the following mapping:

Input	Port	Description
Byte 14 - 45	X1	Byte 0 of IO-Link input data - Byte 31 of IO-Link input data
Byte 46 - 53	X1	Byte 0 of ext. IO-L status - Byte 7 of ext. IO-L status
Byte 54 - 65	X1	Byte 0 of IO-L event data - Byte 11 of IO-L event data
Byte 66 - 97	X2	Byte 0 of IO-Link input data - Byte 31 of IO-Link input data
Byte 98 - 105	X2	Byte 0 of ext. IO-L status - Byte 7 of ext. IO-L status
Byte 106 - 117	X2	Byte 0 of IO-L event data - Byte 11 of IO-L event data
Byte 118 - 149	X3	Byte 0 of IO-Link input data - Byte 31 of IO-Link input data
Byte 150 - 157	X3	Byte 0 of ext. IO-L status - Byte 7 of ext. IO-L status
Byte 158 - 169	X3	Byte 0 of IO-L event data - Byte 11 of IO-L event data
Byte 170 - 201	X4	Byte 0 of IO-Link input data - Byte 31 of IO-Link input data
Byte 202 - 209	X4	Byte 0 of ext. IO-L status - Byte 7 of ext. IO-L status
Byte 210 - 221	X4	Byte 0 of IO-L event data - Byte 11 of IO-L event data
Byte 222 - 253	X5	Byte 0 of IO-Link input data - Byte 31 of IO-Link input data
Byte 254 - 261	X5	Byte 0 of ext. IO-L status - Byte 7 of ext. IO-L status
Byte 262 - 273	X5	Byte 0 of IO-L event data - Byte 11 of IO-L event data
Byte 274 - 305	X6	Byte 0 of IO-Link input data - Byte 31 of IO-Link input data
Byte 306 - 313	X6	Byte 0 of ext. IO-L status - Byte 7 of ext. IO-L status
Byte 314 - 325	X6	Byte 0 of IO-L event data - Byte 11 of IO-L event data
Byte 326 - 357	X7	Byte 0 of IO-Link input data - Byte 31 of IO-Link input data
Byte 358 - 365	X7	Byte 0 of ext. IO-L status - Byte 7 of ext. IO-L status
Byte 366 - 377	X7	Byte 0 of IO-L event data - Byte 11 of IO-L event data
Byte 378 - 409	X8	Byte 0 of IO-Link input data - Byte 31 of IO-Link input data
Byte 410 - 417	X8	Byte 0 of ext. IO-L status - Byte 7 of ext. IO-L status

Input	Port	Description
Byte 418 - 429	X8	Byte 0 of IO-L event data - Byte 11 of IO-L event data

Table 50: Byte 14 - 429, Input data for input assembly 125

The 32 byte input, extended IO-Link status and IO-Link event data per port are zero, if no IO-Link Device is connected to the appropriate port.

8.5 Control data of IO-Link Master (outputs)

For configuring the output data the following EtherNet/IP consuming assemblies are available:

Assembly	Output data
100	4 byte IO-L master control data (without IO-Link Device output data)
102	4 byte IO-L master control data + 4 Byte IO-L device per port
104	4 byte IO-L master control data + 8 Byte IO-L device per port
106	4 byte IO-L master control data + 16 Byte IO-L device per port
108	4 byte IO-L master control data + 32 Byte IO-L device per port

Table 51: Output assemblies

The digital output on the corresponding port can be controlled via the IO-Link Master control data. The IO-Link port must be parametrized as a digital output in the engineering tool. The IO-Link Master consumes in every used consuming assembly configuration the following control data of the IO-Link Master digital outputs:

8.5.1 Control of digital outputs (mapping 1, default) Exclusion: 0980 ESL 3x8-121

If mapping mode 1 was selected in the IO-Link Master parametrization, the digital output data of the module are transferred as follows.

Byte 0 Control data for digital outputs of ports 1 - 4								
Bit	7	6	5	4	3	2	1	0
Port	X4	X4	X3	X3	X2	X2	X1	X1
Pin	-	4	-	4	-	4	-	4
Channel	-	4A	-	3A	-	2A	-	1A

Table 52: Byte 0, Status of digital outputs, mapping 1

Byte 1 Control data for digital outputs of ports 1 - 4								
Bit	7	6	5	4	3	2	1	0
Port	X4	X4	X3	X3	X2	X2	X1	X1
Pin	2	4	2	4	2	4	2	4
Channel	4B	4A	3B	3A	2B	2A	1B	1A

Table 53: Byte 1, Status of digital outputs, mapping 1

- The data contained by the cells highlighted in blue are only available for LioN-P 60 devices.

8.5.2 Control of digital outputs (mapping 2, E2C-comp.) Exclusion: 0980 ESL 3x8-121

If mapping mode 2 was selected in the IO-Link Master parametrization, the digital output data of the module are transferred as follows.

Byte 0 Control data for digital outputs channel A of ports 1 - 8								
Bit	7	6	5	4	3	2	1	0
Port	X8	X7	X6	X5	X4	X3	X2	X1
Pin	4	4	4	4	4	4	4	4
Channel	8A	7A	6A	5A	4A	3A	2A	1A

Table 54: Byte 0, Status of digital outputs for mapping 2

Byte 1 Control data for digital outputs channel A of ports 1 - 8								
Bit	7	6	5	4	3	2	1	0
Port	X8	X7	X6	X5	X4	X3	X2	X1
Pin	2	2	2	2	-	-	-	-
Channel	8B	7B	6B	5B	-	-	-	-

Table 55: Byte 1, Status of digital outputs for mapping 2

- The data contained by the cells highlighted in blue are only available for LioN-P 60 devices.

8.5.3 Control of digital outputs for 0980 ESL 3x8-121 (mapping 1, default)

If mapping mode 1 was selected in the IO-Link Master parametrization, the digital output data of the module are transferred as follows.

Byte 0 Control data for digital outputs of ports 1 - 4								
Bit	7	6	5	4	3	2	1	0
Port	X4	X4	X3	X3	X2	X2	X1	X1
Pin	-	-	-	-	-	-	-	-
Channel	-	-	-	-	-	-	-	-

Table 56: Byte 0, Status of digital outputs for mapping 1

Byte 1 Control data for digital outputs of ports 5 - 8								
Bit	7	6	5	4	3	2	1	0
Port	X8	X8	X7	X7	X6	X6	X5	X5
Pin	2	-	2	-	2	-	2	-
Channel	8B	-	7B	-	6B	-	5B	-

Table 57: Byte 1, Status of digital outputs for mapping 1

8.5.4 Control of digital outputs for 0980 ESL 3x8-121 (mapping 2)

If mapping mode 2 was selected in the IO-Link Master parametrization, the digital output data of the module are transferred as follows.

Byte 0 Control data for digital outputs of ports 1 - 4								
Bit	7	6	5	4	3	2	1	0
Port	X8	X7	X6	X5	X4	X3	X2	X1
Pin	-	-	-	-	-	-	-	-
Channel	-	-	-	-	-	-	-	-

Table 58: Byte 0, Status of digital outputs for mapping 2

Byte 1 Control data for digital outputs of ports 5 - 8								
Bit	7	6	5	4	3	2	1	0
Port	X8	X8	X7	X7	X6	X6	X5	X5
Pin	2	2	2	2	-	-	-	-
Channel	8B	7B	6B	5B	-	-	-	-

Table 59: Byte 1, Status of digital outputs for mapping 2

8.5.5 Control of IO-Link COM mode

This mode can be used to temporarily (as long as the corresponding COM control bit is set) switch one or more IO-Link ports previously in digital input (DI) operating mode to IO-Link operating mode. As a result, it is possible to establish communications with the connected IO-Link Device for parameterization. No process data will be exchanged during this time.

Byte 2 Control data for digital outputs of ports 1 - 4								
Bit	7	6	5	4	3	2	1	0
Port	X8	X7	X6	X5	X4	X3	X2	X1
Pin	4	4	4	4	4	4	4	4
Channel	8A	7A	6A	5A	4A	3A	2A	1A

Table 60: Byte 0, Control of IO-Link COM mode

8.5.6 Reserved

Byte 3 Reserved, do not use								
Bit	7	6	5	4	3	2	1	0
Port	X8	X7	X6	X5	X4	X3	X2	X1
Pin	-	-	-	-	-	-	-	-
Channel	-	-	-	-	-	-	-	-

Table 61: Byte 3, Reserved control byte

8.6 Control data of IO-Link Device (outputs)

8.6.1 IO-Link Device 4 byte output, assembly 102

The assembly 102 provides 4 byte IO-Link output data (master to device) for every IO-Link port with the following mapping:

Input	Port	Description
Byte 4 - 7	X1	Byte 0 of IO-Link output data - Byte 3 of IO-Link output data
Byte 8 - 11	X2	Byte 0 of IO-Link output data - Byte 3 of IO-Link output data
Byte 12 - 15	X3	Byte 0 of IO-Link output data - Byte 3 of IO-Link output data
Byte 16 - 19	X4	Byte 0 of IO-Link output data - Byte 3 of IO-Link output data
Byte 20 - 23	X5	Byte 0 of IO-Link output data - Byte 3 of IO-Link output data
Byte 24 - 27	X6	Byte 0 of IO-Link output data - Byte 3 of IO-Link output data
Byte 28 - 31	X7	Byte 0 of IO-Link output data - Byte 3 of IO-Link output data
Byte 32 - 35	X8	Byte 0 of IO-Link output data - Byte 3 of IO-Link output data

Table 62: Byte 4 - 35, Output data for assembly 102

8.6.2 IO-Link Device 8 byte output, assembly 104

The assembly 104 provides 8 byte IO-Link output data (master to device) for every IO-Link port with the following mapping:

Input	Port	Description
Byte 4 - 11	X1	Byte 0 of IO-Link output data - Byte 7 of IO-Link output data
Byte 12 - 19	X2	Byte 0 of IO-Link output data - Byte 7 of IO-Link output data
Byte 20 - 27	X3	Byte 0 of IO-Link output data - Byte 7 of IO-Link output data
Byte 28 - 35	X4	Byte 0 of IO-Link output data - Byte 7 of IO-Link output data
Byte 36 - 43	X5	Byte 0 of IO-Link output data - Byte 7 of IO-Link output data
Byte 44 - 51	X6	Byte 0 of IO-Link output data - Byte 7 of IO-Link output data
Byte 52 - 59	X7	Byte 0 of IO-Link output data - Byte 7 of IO-Link output data
Byte 60 - 67	X8	Byte 0 of IO-Link output data - Byte 7 of IO-Link output data

Table 63: Byte 4 - 67, Output data for assembly 104

8.6.3 IO-Link Device 16 byte output, assembly 106

The assembly 106 provides 16 byte IO-Link output data (master to device) for every IO-Link port with the following mapping:

Input	Port	Description
Byte 4 - 19	X1	Byte 0 of IO-Link output data - Byte 15 of IO-Link output data
Byte 20 - 35	X2	Byte 0 of IO-Link output data - Byte 15 of IO-Link output data
Byte 36 - 51	X3	Byte 0 of IO-Link output data - Byte 15 of IO-Link output data
Byte 52 - 67	X4	Byte 0 of IO-Link output data - Byte 15 of IO-Link output data
Byte 68 - 83	X5	Byte 0 of IO-Link output data - Byte 15 of IO-Link output data
Byte 84 - 99	X6	Byte 0 of IO-Link output data - Byte 15 of IO-Link output data
Byte 100 - 115	X7	Byte 0 of IO-Link output data - Byte 15 of IO-Link output data
Byte 116 - 131	X8	Byte 0 of IO-Link output data - Byte 15 of IO-Link output data

Table 64: Byte 4 - 131, Output data for assembly 106

8.6.4 IO-Link Device 32 byte output, assembly 108

The assembly 108 provides 32 byte IO-Link output data (master to device) for every IO-Link port with the following mapping:

Input	Port	Description
Byte 4 - 35	X1	Byte 0 of IO-Link output data - Byte 31 of IO-Link output data
Byte 36 - 67	X2	Byte 0 of IO-Link output data - Byte 31 of IO-Link output data
Byte 68 - 99	X3	Byte 0 of IO-Link output data - Byte 31 of IO-Link output data
Byte 100 - 131	X4	Byte 0 of IO-Link output data - Byte 31 of IO-Link output data
Byte 132 - 163	X5	Byte 0 of IO-Link output data - Byte 31 of IO-Link output data
Byte 164 - 195	X6	Byte 0 of IO-Link output data - Byte 31 of IO-Link output data
Byte 196 - 227	X7	Byte 0 of IO-Link output data - Byte 31 of IO-Link output data
Byte 228 - 259	X8	Byte 0 of IO-Link output data - Byte 31 of IO-Link output data

Table 65: Byte 4 - 259, Output data for assembly 108

9 Diagnostics processing

9.1 Error in the system/sensor power supply

The voltage value for the incoming system/sensor power supply is also monitored globally. If the voltage drops below approx. 18.6 V or exceeds approx. 30 V, an error message will be generated.

The green U_S indicator is unlit.

The error message has no effect on the outputs.



Caution: It must definitely be ensured that the supply voltage, measured at the most remote participant, is not below 18 V DC from the perspective of the system power supply.

The following table shows the used diagnosis bits in the status data of the IO-Link Master:

Input	Bit 7	Bit 6	Bit 5	Bit 4	Bit 3	Bit 2	Bit 1	Bit 0
Byte 4	0	MI-FMA	MI-VAL	MI-SCB	MI-SCA	MI-SCS	MI-LVA	MI-LVS
Byte 5	0	0	0	0	0	IOL-DN	IOL-DW	IOL-DE
Byte 6	SCS-X8	SCS-X7	SCS-X6	SCS-X5	SCS-X4	SCS-X3	SCS-X2	SCS-X1
Byte 7	0	0	0	0	0	0	0	0
Byte 8	CE-X8A	CE-X7A	CE-X6A	CE-X5A	CE-X4A	CE-X3A	CE-X2A	CE-X1A
Byte 9	CE-X8B	CE-X7B	CE-X6B	CE-X5B	0	0	0	0
Byte 10	DE-X8A	DE-X7A	DE-X6A	DE-X5A	DE-X4A	DE-X3A	DE-X2A	DE-X1A
Byte 11	DW-X8A	DW-X7A	DW-X6A	DW-X5A	DW-X4A	DW-X3A	DW-X2A	DW-X1A
Byte 12	DN-X8A	DN-X7A	DN-X6A	DN-X5A	DN-X4A	DN-X3A	DN-X2A	DN-X1A
Byte 13	VAL-X8	VAL-X7	VAL-X6	VAL-X5	VAL-X4	VAL-X3	VAL-X2	VAL-X1

Table 66: Status of module diagnostic MI-LVS

9.2 Error in auxiliary/actuator power supply

The voltage value for the incoming auxiliary/actuator power supply is also monitored globally. If U_{Aux} diagnostic messaging is enabled, an error message is generated if the voltage drops below approx. 18.6 V or exceeds approx. 30 V.

The U_{Aux} indicator shows red.

If output channels are enabled, additional error messages caused by the voltage failure are generated on the I/O ports.

U_{Aux} diagnostic messaging is disabled by default and must be enabled via parameterization.

The following table shows the used diagnosis bits in the status data of the IO-Link Master:

Input	Bit 7	Bit 6	Bit 5	Bit 4	Bit 3	Bit 2	Bit 1	Bit 0
Byte 4	0	MI-FMA	MI-VAL	MI-SCB	MI-SCA	MI-SCS	MI-LVA	MI-LVS
Byte 5	0	0	0	0	0	IOL-DN	IOL-DW	IOL-DE
Byte 6	SCS-X8	SCS-X7	SCS-X6	SCS-X5	SCS-X4	SCS-X3	SCS-X2	SCS-X1
Byte 7	0	0	0	0	0	0	0	0
Byte 8	CE-X8A	CE-X7A	CE-X6A	CE-X5A	CE-X4A	CE-X3A	CE-X2A	CE-X1A
Byte 9	CE-X8B	CE-X7B	CE-X6B	CE-X5B	0	0	0	0
Byte 10	DE-X8A	DE-X7A	DE-X6A	DE-X5A	DE-X4A	DE-X3A	DE-X2A	DE-X1A
Byte 11	DW-X8A	DW-X7A	DW-X6A	DW-X5A	DW-X4A	DW-X3A	DW-X2A	DW-X1A
Byte 12	DN-X8A	DN-X7A	DN-X6A	DN-X5A	DN-X4A	DN-X3A	DN-X2A	DN-X1A
Byte 13	VAL-X8	VAL-X7	VAL-X6	VAL-X5	VAL-X4	VAL-X3	VAL-X2	VAL-X1

Table 67: Status of module diagnostic MI-LVA

9.3 Overload/short-circuit of the I/O port sensor supply outputs

In case of an overload or a short circuit between Pin 1 and Pin 3 on the ports (X1 - X8), the following channel-specific diagnostic messages are generated:

Input	Bit 7	Bit 6	Bit 5	Bit 4	Bit 3	Bit 2	Bit 1	Bit 0
Byte 4	0	MI-FMA	MI-VAL	MI-SCB	MI-SCA	MI-SCS	MI-LVA	MI-LVS
Byte 5	0	0	0	0	0	IOL-DN	IOL-DW	IOL-DE
Byte 6	SCS-X8	SCS-X7	SCS-X6	SCS-X5	SCS-X4	SCS-X3	SCS-X2	SCS-X1
Byte 7	0	0	0	0	0	0	0	0
Byte 8	CE-X8A	CE-X7A	CE-X6A	CE-X5A	CE-X4A	CE-X3A	CE-X2A	CE-X1A
Byte 9	CE-X8B	CE-X7B	CE-X6B	CE-X5B	0	0	0	0
Byte 10	DE-X8A	DE-X7A	DE-X6A	DE-X5A	DE-X4A	DE-X3A	DE-X2A	DE-X1A
Byte 11	DW-X8A	DW-X7A	DW-X6A	DW-X5A	DW-X4A	DW-X3A	DW-X2A	DW-X1A
Byte 12	DN-X8A	DN-X7A	DN-X6A	DN-X5A	DN-X4A	DN-X3A	DN-X2A	DN-X1A
Byte 13	VAL-X8	VAL-X7	VAL-X6	VAL-X5	VAL-X4	VAL-X3	VAL-X2	VAL-X1

Table 68: Status of module diagnostic MI-SCS

9.4 Overload/short circuit of the digital 500 mA outputs

The digital outputs on the C/Q Pin (not available for 0980 ESL 3x8-121) are short circuit and overload protected. In case of a fault, the output is automatically switched off and cyclically automatically switched back on.

Input	Bit 7	Bit 6	Bit 5	Bit 4	Bit 3	Bit 2	Bit 1	Bit 0
Byte 4	0	MI-FMA	MI-VAL	MI-SCB	MI-SCA	MI-SCS	MI-LVA	MI-LVS
Byte 5	0	0	0	0	0	IOL-DN	IOL-DW	IOL-DE
Byte 6	SCS-X8	SCS-X7	SCS-X6	SCS-X5	SCS-X4	SCS-X3	SCS-X2	SCS-X1
Byte 7	0	0	0	0	0	0	0	0
Byte 8	CE-X8A	CE-X7A	CE-X6A	CE-X5A	CE-X4A	CE-X3A	CE-X2A	CE-X1A
Byte 9	CE-X8B	CE-X7B	CE-X6B	CE-X5B	0	0	0	0
Byte 10	DE-X8A	DE-X7A	DE-X6A	DE-X5A	DE-X4A	DE-X3A	DE-X2A	DE-X1A
Byte 11	DW-X8A	DW-X7A	DW-X6A	DW-X5A	DW-X4A	DW-X3A	DW-X2A	DW-X1A
Byte 12	DN-X8A	DN-X7A	DN-X6A	DN-X5A	DN-X4A	DN-X3A	DN-X2A	DN-X1A
Byte 13	VAL-X8	VAL-X7	VAL-X6	VAL-X5	VAL-X4	VAL-X3	VAL-X2	VAL-X1

Table 69: Status of module diagnostic MI-SCA

9.5 Overload/short circuit of the digital 2.0 A outputs

There are four 2.0 A (1.6 A for 0980 ESL 3x8-121) outputs on the Class B ports of the LioN-P 60 devices.

A channel error is determined by comparing the target value set by a controller and the actual value of an output channel.

Target value	Actual value	Comment
Active	Active	OK, no diagnosis
Off	Off	OK, no diagnosis
Active	Off	Short-circuit Channel indicator is red. Channel error bit in the diagnosis is set. Channel is locked after the error is rectified.

Table 70: Interpretation of channel errors

When an output channel is activated (rising edge of the channel state) or deactivated (falling edge), the channel errors are filtered for the period that you set using the Surveillance-Timeout parameter during the configuration of the module. The value of this parameter can range from 0 to 255 ms; the factory setting is 80 ms.

The filter is used to avoid premature error messages when a capacitive load is activated or an inductive load is deactivated, and during other voltage peaks when a status changes.

In static state of the output channel, that is, while the channel is permanently switched on or off, the filter time between error detection and the diagnostic message is typically 5-10 ms.

The following table shows the used diagnosis bits in the status data of the IO-Link Master:

Input	Bit 7	Bit 6	Bit 5	Bit 4	Bit 3	Bit 2	Bit 1	Bit 0
Byte 4	0	MI-FMA	MI-VAL	MI-SCB	MI-SCA	MI-SCS	MI-LVA	MI-LVS
Byte 5	0	0	0	0	0	IOL-DN	IOL-DW	IOL-DE
Byte 6	SCS-X8	SCS-X7	SCS-X6	SCS-X5	SCS-X4	SCS-X3	SCS-X2	SCS-X1
Byte 7	0	0	0	0	0	0	0	0
Byte 8	CE-X8A	CE-X7A	CE-X6A	CE-X5A	CE-X4A	CE-X3A	CE-X2A	CE-X1A
Byte 9	CE-X8B	CE-X7B	CE-X6B	CE-X5B	0	0	0	0
Byte 10	DE-X8A	DE-X7A	DE-X6A	DE-X5A	DE-X4A	DE-X3A	DE-X2A	DE-X1A
Byte 11	DW-X8A	DW-X7A	DW-X6A	DW-X5A	DW-X4A	DW-X3A	DW-X2A	DW-X1A
Byte 12	DN-X8A	DN-X7A	DN-X6A	DN-X5A	DN-X4A	DN-X3A	DN-X2A	DN-X1A
Byte 13	VAL-X8	VAL-X7	VAL-X6	VAL-X5	VAL-X4	VAL-X3	VAL-X2	VAL-X1

Table 71: Status of module diagnostic MI-SCB

9.6 Overload/short circuit of the type B port aux. power supply

9.6.1 For LioN-P 30 devices

In case of an overload or a short circuit between Pin 2 and Pin 5 on these ports (X5 - X8), the following diagnosis bits in the status data of the IO-Link Master can be set:

Input	Bit 7	Bit 6	Bit 5	Bit 4	Bit 3	Bit 2	Bit 1	Bit 0
Byte 4	0	MI-FMA	MI-VAL	MI-SCB	MI-SCA	MI-SCS	MI-LVA	MI-LVS
Byte 5	0	0	0	0	0	IOL-DN	IOL-DW	IOL-DE
Byte 6	SCS-X8	SCS-X7	SCS-X6	SCS-X5	SCS-X4	SCS-X3	SCS-X2	SCS-X1
Byte 7	0	0	0	0	0	0	0	0
Byte 8	CE-X8A	CE-X7A	CE-X6A	CE-X5A	CE-X4A	CE-X3A	CE-X2A	CE-X1A
Byte 9	CE-X8B	CE-X7B	CE-X6B	CE-X5B	0	0	0	0
Byte 10	DE-X8A	DE-X7A	DE-X6A	DE-X5A	DE-X4A	DE-X3A	DE-X2A	DE-X1A
Byte 11	DW-X8A	DW-X7A	DW-X6A	DW-X5A	DW-X4A	DW-X3A	DW-X2A	DW-X1A
Byte 12	DN-X8A	DN-X7A	DN-X6A	DN-X5A	DN-X4A	DN-X3A	DN-X2A	DN-X1A
Byte 13	VAL-X8	VAL-X7	VAL-X6	VAL-X5	VAL-X4	VAL-X3	VAL-X2	VAL-X1

Table 72: Status of module diagnostic MI-SCB for LioN-P 30

9.6.2 For LioN-P 60 devices

In case of an overload or a short circuit between Pin 2 and Pin 5 on these ports (X5 - X8), the following group diagnostic message (not channelspecific) is generated in the status data of the IO-Link Master:

Input	Bit 7	Bit 6	Bit 5	Bit 4	Bit 3	Bit 2	Bit 1	Bit 0
Byte 4	0	MI-FMA	MI-VAL	MI-SCB	MI-SCA	MI-SCS	MI-LVA	MI-LVS
Byte 5	0	0	0	0	0	IOL-DN	IOL-DW	IOL-DE
Byte 6	SCS-X8	SCS-X7	SCS-X6	SCS-X5	SCS-X4	SCS-X3	SCS-X2	SCS-X1
Byte 7	0	0	0	0	0	0	0	0
Byte 8	CE-X8A	CE-X7A	CE-X6A	CE-X5A	CE-X4A	CE-X3A	CE-X2A	CE-X1A
Byte 9	CE-X8B	CE-X7B	CE-X6B	CE-X5B	0	0	0	0
Byte 10	DE-X8A	DE-X7A	DE-X6A	DE-X5A	DE-X4A	DE-X3A	DE-X2A	DE-X1A
Byte 11	DW-X8A	DW-X7A	DW-X6A	DW-X5A	DW-X4A	DW-X3A	DW-X2A	DW-X1A
Byte 12	DN-X8A	DN-X7A	DN-X6A	DN-X5A	DN-X4A	DN-X3A	DN-X2A	DN-X1A
Byte 13	VAL-X8	VAL-X7	VAL-X6	VAL-X5	VAL-X4	VAL-X3	VAL-X2	VAL-X1

Table 73: Status of module diagnostic MI-SCB in aux. power supply mode

9.7 IO-Link Master error

9.7.1 IO-Link C/Q error

If an IO-Link Device in COM mode is unplugged or an electrical fault occurs on the C/Q (Pin 4) line, for example, due to a short circuit, then following diagnosis bits can be set in the IO-Link Master status data:

Input	Bit 7	Bit 6	Bit 5	Bit 4	Bit 3	Bit 2	Bit 1	Bit 0
Byte 4	0	MI-FMA	MI-VAL	MI-SCB	MI-SCA	MI-SCS	MI-LVA	MI-LVS
Byte 5	0	0	0	0	0	IOL-DN	IOL-DW	IOL-DE
Byte 6	SCS-X8	SCS-X7	SCS-X6	SCS-X5	SCS-X4	SCS-X3	SCS-X2	SCS-X1
Byte 7	0	0	0	0	0	0	0	0
Byte 8	CE-X8A	CE-X7A	CE-X6A	CE-X5A	CE-X4A	CE-X3A	CE-X2A	CE-X1A
Byte 9	CE-X8B	CE-X7B	CE-X6B	CE-X5B	0	0	0	0
Byte 10	DE-X8A	DE-X7A	DE-X6A	DE-X5A	DE-X4A	DE-X3A	DE-X2A	DE-X1A
Byte 11	DW-X8A	DW-X7A	DW-X6A	DW-X5A	DW-X4A	DW-X3A	DW-X2A	DW-X1A
Byte 12	DN-X8A	DN-X7A	DN-X6A	DN-X5A	DN-X4A	DN-X3A	DN-X2A	DN-X1A
Byte 13	VAL-X8	VAL-X7	VAL-X6	VAL-X5	VAL-X4	VAL-X3	VAL-X2	VAL-X1

Table 74: Status of module diagnostic MI-SCA

9.7.2 IO-Link validation error

If an IO-Link Device in COM mode is unplugged (and the validation is parameterized), a validation error is detected, e.g. by wrong Vendor ID or Device ID, then the following diagnosis bits can be set in the IO-Link Master status data:

Input	Bit 7	Bit 6	Bit 5	Bit 4	Bit 3	Bit 2	Bit 1	Bit 0
Byte 4	0	MI-FMA	MI-VAL	MI-SCB	MI-SCA	MI-SCS	MI-LVA	MI-LVS
Byte 5	0	0	0	0	0	IOL-DN	IOL-DW	IOL-DE
Byte 6	SCS-X8	SCS-X7	SCS-X6	SCS-X5	SCS-X4	SCS-X3	SCS-X2	SCS-X1
Byte 7	0	0	0	0	0	0	0	0
Byte 8	CE-X8A	CE-X7A	CE-X6A	CE-X5A	CE-X4A	CE-X3A	CE-X2A	CE-X1A
Byte 9	CE-X8B	CE-X7B	CE-X6B	CE-X5B	0	0	0	0
Byte 10	DE-X8A	DE-X7A	DE-X6A	DE-X5A	DE-X4A	DE-X3A	DE-X2A	DE-X1A
Byte 11	DW-X8A	DW-X7A	DW-X6A	DW-X5A	DW-X4A	DW-X3A	DW-X2A	DW-X1A
Byte 12	DN-X8A	DN-X7A	DN-X6A	DN-X5A	DN-X4A	DN-X3A	DN-X2A	DN-X1A
Byte 13	VAL-X8	VAL-X7	VAL-X6	VAL-X5	VAL-X4	VAL-X3	VAL-X2	VAL-X1

Table 75: Status of module diagnostic MI-VAL

9.8 IO-Link Device diagnostics

Diagnosis of IO-Link Devices can have the level error, warning or notification.

9.8.1 IO-Link Device error

In case of an error diagnosis send from device to master, the following diagnosis bits can be set in the IO-Link Master status data:

Input	Bit 7	Bit 6	Bit 5	Bit 4	Bit 3	Bit 2	Bit 1	Bit 0
Byte 4	0	MI-FMA	MI-VAL	MI-SCB	MI-SCA	MI-SCS	MI-LVA	MI-LVS
Byte 5	0	0	0	0	0	IOL-DN	IOL-DW	IOL-DE
Byte 6	SCS-X8	SCS-X7	SCS-X6	SCS-X5	SCS-X4	SCS-X3	SCS-X2	SCS-X1
Byte 7	VAL-X8	VAL-X8	VAL-X8	VAL-X8	VAL-X8	VAL-X8	VAL-X8	VAL-X8
Byte 8	CE-X8A	CE-X7A	CE-X6A	CE-X5A	CE-X4A	CE-X3A	CE-X2A	CE-X1A
Byte 9	CE-X8B	CE-X7B	CE-X6B	CE-X5B	0	0	0	0
Byte 10	DE-X8A	DE-X7A	DE-X6A	DE-X5A	DE-X4A	DE-X3A	DE-X2A	DE-X1A
Byte 11	DW-X8A	DW-X7A	DW-X6A	DW-X5A	DW-X4A	DW-X3A	DW-X2A	DW-X1A
Byte 12	DN-X8A	DN-X7A	DN-X6A	DN-X5A	DN-X4A	DN-X3A	DN-X2A	DN-X1A
Byte 13	VAL-X8	VAL-X7	VAL-X6	VAL-X5	VAL-X4	VAL-X3	VAL-X2	VAL-X1

Table 76: Status of module diagnostic IOL-DE

9.8.2 IO-Link Device warning

In case of a warning diagnosis send from device to master, the following diagnosis bits can be set in the IO-Link Master status data:

Input	Bit 7	Bit 6	Bit 5	Bit 4	Bit 3	Bit 2	Bit 1	Bit 0
Byte 4	0	MI-FMA	MI-VAL	MI-SCB	MI-SCA	MI-SCS	MI-LVA	MI-LVS
Byte 5	0	0	0	0	0	IOL-DN	IOL-DW	IOL-DE
Byte 6	SCS-X8	SCS-X7	SCS-X6	SCS-X5	SCS-X4	SCS-X3	SCS-X2	SCS-X1
Byte 7	VAL-X8	VAL-X8	VAL-X8	VAL-X8	VAL-X8	VAL-X8	VAL-X8	VAL-X8
Byte 8	CE-X8A	CE-X7A	CE-X6A	CE-X5A	CE-X4A	CE-X3A	CE-X2A	CE-X1A
Byte 9	CE-X8B	CE-X7B	CE-X6B	CE-X5B	0	0	0	0
Byte 10	DE-X8A	DE-X7A	DE-X6A	DE-X5A	DE-X4A	DE-X3A	DE-X2A	DE-X1A
Byte 11	DW-X8A	DW-X7A	DW-X6A	DW-X5A	DW-X4A	DW-X3A	DW-X2A	DW-X1A
Byte 12	DN-X8A	DN-X7A	DN-X6A	DN-X5A	DN-X4A	DN-X3A	DN-X2A	DN-X1A
Byte 13	VAL-X8	VAL-X7	VAL-X6	VAL-X5	VAL-X4	VAL-X3	VAL-X2	VAL-X1

Table 77: Status of module diagnostic IOL-DN

10 EtherNet/IP objects

The following EtherNet/IP objects are supported by the device:

- ▶ Identity Object (Class-Code 0x01)
- ▶ Assembly Object (Class-Code 0x04)
- ▶ Connection Manager Object (Class-Code 0x06)
- ▶ EtherNet/IP Link Object (Class-Code 0xF6)
- ▶ TCP/IP Object (Class-Code 0xF5)
- ▶ Quality of Service Object (Class-Code 0x48)
- ▶ DLR Object (Class-Code 0x47)
- ▶ IO-Link Device Parameter Object (Class-Code 0x80), vendor specific
- ▶ IO-Link Failsafe Parameter Object (Class-Code 0x81), vendor specific

10.1 IO-Link Device parameter object (Class Code 0x80)

This vendor specific object supports reading or writing of IO-Link Device parameter.

10.1.1 Read ISDU service (Class Code 0x80)

The read ISDU service request parameters are defined as follows:

Name	Value	Type	Description
Class	0x80		IO-Link Device parameter object
Instance	1		IO-Link Master
Instance Attribute	1 – 8		IO-Link port number
Service Code	0x4B		READ ISDU code
Index	() ⁴	UINT	IO-Link ISDU object index
Sub Index	() ⁴	USINT	IO-Link ISDU object sub-index

Table 78: 0x80 Read ISDU request

If the read request was successful (General Status of the CIP response is 0), the following response format is available.

Name	Type	Description
ISDU	Array of Byte	Max. 232 bytes

Table 79: General status of CIP response equals 0

If the read request was not successful (General Status of the CIP response is unequal 0), the following response format is available:

⁴ Depends on the connected IO-Link Device, refer to the IO-Link Device documentation.

Name	Type	Error Code Description	Error Code
IO-Link Master Error	UINT	Service not available	1
		Port blocked	2
		Timeout	3
		Invalid index	4
		Invalid sub-index	5
		Wrong port	6
		Wrong port function	7
		Invalid length	8
		ISDU not supported	9
IO-Link Device Error	USINT	Refer to IO-Link specification	–
IO-Link Device Additional Error	USINT	Refer to IO-Link specification	–

Table 80: 0x80 Read ISDU negative

10.1.2 Write ISDU service (Class Code 0x80)

The write ISDU service request parameters are defined as follows:

Name	Value	Type	Description
Class	0x80		IO-Link Device parameter object
Instance	1		IO-Link Master
Instance Attribute	1 – 8		IO-Link port number
Service Code	0x4C		WRITE ISDU code
Index	() ⁴	UINT	IO-Link ISDU object index
Sub Index	() ⁴	USINT	IO-Link ISDU object sub-index
Data	() ⁴	Array of Bytes	IO-Link ISDU data, max. 232 bytes

Table 81: 0x80 Write ISDU request

If the write request was successful, the General Status of the CIP response is 0.

If the write request was not successful (General Status of the CIP response is unequal 0), the following response format is available:

Name	Type	Error Code Description	Error Code
IO-Link Master Error	UINT	Service not available	1
		Port blocked	2
		Timeout	3
		Invalid index	4
		Invalid sub-index	5
		Wrong port	6
		Wrong port function	7
		Invalid length	8
		ISDU not supported	9
IO-Link Device Error	USINT	Refer to IO-Link specification	–
IO-Link Device Additional Error	USINT	Refer to IO-Link specification	–

Table 82: 0x80 Write ISDU negative

10.2 IO-Link failsafe parameter Object (Class-Code 0x81)

In case of an EtherNet/IP communication loss, failsafe values can be defined for the IO-Link Device output data.

If in the IO-Link Port Parameter settings the option **Replacement Value** was set, then the substitute value transferred by this Class-Code 0x81 will be transferred as output data to the IO-Link Device. The values must be written into the IO-Link Master after every power on cycle.

The value must be entered as in MSB to LSB byte order, depending on the configured data length and used IO-Link Device.

10.2.1 Set failsafe parameter (Class Code 0x81)

The set failsafe service **request** parameters are defined as follows:

Name	Value	Type	Description
Class	0x80		IO-Link Device parameter object
Instance	1		IO-Link Master failsafe
Instance Attribute	1 – 8		IO-Link port number
Service Code	0x10		Set attribute single
Data	() ⁴	Array of Bytes	Failsafe value of IO-Link port

Table 83: 0x80 Set failsafe parameter

If the set request was successful the General Status of the CIP response is 0.

10.2.2 Get failsafe parameter (Class Code 0x81)

The get failsafe service **request** parameters are defined as follows:

Name	Value	Type	Description
Class	0x81		IO-Link Device parameter object
Instance	1		IO-Link Master failsafe
Instance Attribute	1 – 8		IO-Link port number
Service Code	0x0E		Get attribute single
Data	() ⁴	Array of Bytes	Failsafe value of IO-Link port

Table 84: 0x81 Get failsafe parameter

If the get request was successful the General Status of the CIP response is 0.

11 The integrated web server

The LiON-P modules are equipped with an integrated web server which makes functions available for the configuration of modules and display of status and diagnostic information.

Enter `http://` followed by the IP address, such as `http://192.168.1.5`, in your web browser's address bar. If the home page of the module is not displayed, check your browser and firewall settings.

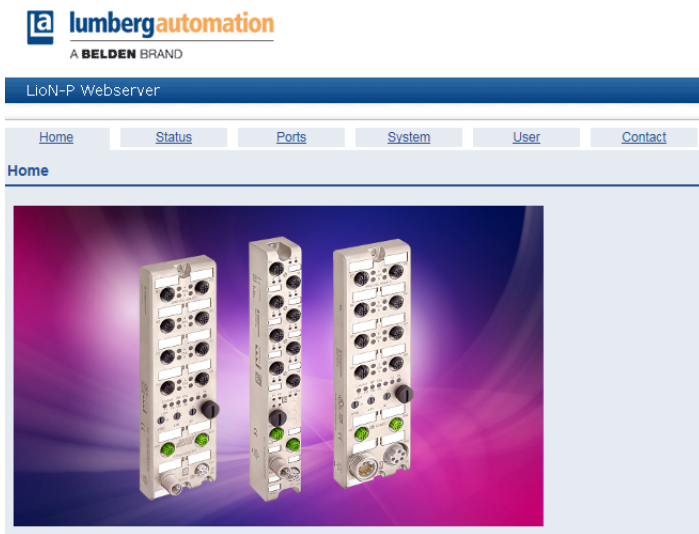

The web interface provides an overview of the configuration and status of the module. Also, certain settings can be made. It is also possible to use the web interface to trigger a reboot, reset to the factory defaults, or perform a firmware update.

11.1 The Status page



LiON-P Webserver

Home Status Ports System User Contact

Status

Device Overview

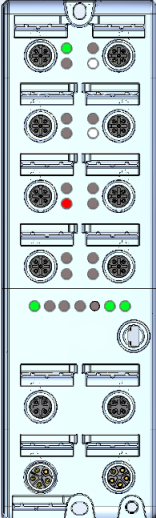

Device Information

Name	0980 ESL 319-121
Bus	ON
Device Diagnosis	
IO-Link Master Diagnosis	
Forcemode	Forcemode locked

Port Information

Port	Type	Pin / Channel	Function	State	Dia	Details
X1	IO-Link Class A + DI	4 / A	IO-Link 0 Bytes In, 2 Bytes Out	Operate		①
		2 / B	Digital Input 1 Bit In / NO	OFF		
X2	IO-Link Class A + DI	4 / A	Digital Input 1 Bit In / NO	OFF		①
		2 / B	Digital Input 1 Bit In / NO	OFF		
X3	IO-Link Class A + DI	4 / A	Digital Input 1 Bit In / NO	OFF	DIA	①
		2 / B	Digital Input 1 Bit In / NO	OFF		
X4	IO-Link Class A + DI	4 / A	Digital Input 1 Bit In / NO	OFF		①
		2 / B	Digital Input 1 Bit In / NO	OFF		
X5	IO-Link Class B + DO	4 / A	Digital Input 1 Bit In / NO	OFF		①
		2 / B	Digital Output 1 Bit Out	ON		
X6	IO-Link Class B + DO	4 / A	Digital Input 1 Bit In / NO	OFF		①
		2 / B	Digital Output 1 Bit Out	ON		
X7	IO-Link Class B + DO	4 / A	Digital Input 1 Bit In / NO	OFF		①
		2 / B	AUX Power			
X8	IO-Link Class B + DO	4 / A	Digital Input 1 Bit In / NO	OFF		①
		2 / B	AUX Power			

The status page provides a quick overview of the current state of the module.

The left side shows a graphical representation of the module with all its LEDs and the positions of the rotary encoding switches.

The right side shows the **Device Information** table with some basic data for the module; for example, the variant, the cyclic communication status and a diagnostic indicator. The indicator shows whether a diagnosis for the module exists.

The **Port Information** table shows the configuration and state of all the module's I/O ports.

Column	Information
Port	Name of port
Type	Type of port. This can be DIO, IOL A or IOL B depending on the variant. The +DO supplement indicates that an additional 2 A output is available here.
	Corresponding Pin on the M8/M12 slot
Function	Function configured via control
State	Current status. ON or OFF is displayed here for digital inputs or outputs. The COM status is displayed for IO-Link connections.
Dia	The diagnostics indicator shows whether a diagnosis exists for this channel.
Details	This link can be used to jump directly to the corresponding detailed view for this port. More information is then available.

Table 85: Web server status description



Warning: Using of the Forcemode can result in serious personal injury or damage to the equipment. Be careful when using the Forcemode.

11.2 The Ports page

The screenshot displays the 'Ports' page of the Lumberg Automation web interface. The interface includes a navigation menu with 'Home', 'Status', 'Ports', 'System', 'User', and 'Contact'. The 'Ports' section is active, showing a list of ports (X1 through X8) with X1 selected. Below the port list, there are two main panels: 'Port Information' and 'Port Diagnosis'. The 'Port Information' panel shows details for 'Pin 4', including its function (IO-Link), state (Open), and various identification numbers (Vendor ID, Device ID, Device Name, Serial No.). The 'Port Diagnosis' panel shows details for 'Pin 2', including its function (Digital Input) and state (OK). The 'Port Diagnosis' panel also includes a 'Name (Tag)' field with a 'Set' button and 'Input Data' and 'Output Data' fields.

Detailed information about the port is shown here.

Port Diagnosis shows incoming and outgoing diagnoses in clear text. "Pin 2" and "Pin 4" contain information about the configuration and state of the port. For IO-Link ports, additional information relating to the connected sensor and the process data is displayed.

11.3 The System page

The screenshot displays the 'System' page of the LioN-P Webserver. At the top, there is a navigation bar with tabs for Home, Status, Ports, System (selected), User, and Contact. Below the navigation bar, the page is titled 'System' and contains a 'General Information' section. This section is divided into several sub-sections: Firmware, Device, Ethernet, Network, and Fieldbus. Each sub-section lists specific details about the device's configuration and status. At the bottom of the page, there are three control sections: 'Restart device', 'Reset configuration to factory defaults', and 'Firmware update', each with a corresponding button and a confirmation checkbox.

General Information	
Firmware	
Name	LioN-P Ethernet/IP IOL Master
Version	V.0.9.4.0 - 14.10.2016 / Web: 13
Device	
Name	0980 ESL 319-121
Ordering Number	934 839 004
Hardware	V.1.0
Serial Number	12345
Production Date	32 / 2015
Ethernet	
MAC Address	3C B9 A6 00 17 00
Port 0	100M Full
Port 1	Link Down
Network	
IP-Address	192.168.1.3
Subnetmask	255.255.255.0
Gateway	0.0.0.0
Fieldbus	
Name of Station	
State	Data exchange

Restart device
 Confirm to restart the device. All connections will be closed.
 Restart

Reset configuration to factory defaults
 Confirm to reset the device. All configuration data will be overwritten by default values!
 Factory Reset

Firmware update
 FW-Update

The System page shows basic information for the module. The current firmware, its version, and the firmware date can be viewed below **Firmware** as well as the version of the web interface.

All the information about the module itself is located below **Device**.

For a firmware update chose the *.ZIP container provided by our website or asking our support team to send it to you. Afterwards follow the instructions.

11.4 The User page

The User page provides the user management of the web interface. New users with access rights **Admin** or **Write** can be added here. For security reasons please change the default admin password immediately after configuring the device. Default login settings:

- ▶ User name: admin
- ▶ Password: private

lumbergautomation
A BELDEN BRAND

LioN-P Webservers

Home Status Ports System **User** Contact

Users

Username	Permissions	Edit	Del
admin	Admin		
Service	Write permissions		

Create User

Login: Permission: Write

12 Technical data

12.1 General

Protection class (This only applies if the connectors are screwed together or if protective caps are used.) ⁵	For all Digital LioN-P modules:	IP65, IP67
	Only for modules with M12-L power connector (not for modules with 7/8" power connector):	IP69
Ambient air temperature (operation)	-4° F to +158° F (-20° C to +70° C)	
Ambient air temperature EEC variants (operation)	-40° F to +158° F (-40° C to +70° C)	
Weight	LioN-P 30	480g
	LioN-P 60	500g
Ambient moisture	max. 98% RH (for UL certification: max. 80% RH)	
Housing material	Die-cast zinc	
Surface finish	Matt nickel	
Flammability class	UL 94 (IEC 61010)	
Vibration resistance (oscillation) DIN EN 60068-2-6 (2008-11)	15 g / 5-500 Hz	
Shock resistance DIN EN 60068-2-27 (2010-02)	50 g / 11 ms +/- X,Y,Z	
Torques	M4 fixing screws	1 Nm
	M4 ground connection	1 Nm
	M8 connector	0.5 Nm
	M12 connector	0.5 Nm

Table 86: General information

⁵ Not under UL investigation.

12.2 EtherNet/IP protocol

Protocol	EtherNet/IP
Update cycle	1 ms
EDS files	EDS-V3.11.1-LumbergAutomation-0980ESL199-121-yyyyymmdd.eds EDS-V3.11.1-LumbergAutomation-0980ESL199-122-yyyyymmdd.eds EDS-V3.11.1-LumbergAutomation-0980ESL199-331-yyyyymmdd.eds EDS-V3.11.1-LumbergAutomation-0980ESL199-332-yyyyymmdd.eds EDS-V3.11.1-LumbergAutomation-0980ESL398-121-yyyyymmdd.eds EDS-V3.11.1-LumbergAutomation-0980ESL399-121-yyyyymmdd.eds
Data transmission rate	10/100 Mbit/s, full duplex
Transmission procedure	100BASE-TX
Autonegotiation	is supported
RPI max.	1 ms
Manufacturer ID	21
Product code (number)	12
Product code (character string)	"Communications Adapter"
Product code	19902 (0980 ESL 199-121, IOL M12P MP) 19903 (0980 ESL 199-122, IOL M12P MP) 19904 (0980 ESL 199-331, IOL HYB M12 MP) 19905 (0980 ESL 199-331, IOL HYB M8 MP) 39802 (0980 ESL 398-121, IOL M12P MP) 39902 (0980 ESL 399-121, IOL M12P MP) 39972 (0980 ESL 399-121-EEC, IOL M12P MP)
Supported Ethernet protocol	Ping ARP HTTP TCP/IP DHCP BOOTP DLR (beacon-based)

Switch functions	integrated
EtherNet/IP interface Port Autocrossing	2 M12 sockets 4-pin, D-coded (see pin assignment) is supported

Table 87: Technical data EtherNet/IP

12.3 Power supply for the module electronics/sensors

Nominal voltage U_S	24 V DC (SELV/PELV)	
Voltage range	18 - 30 V DC	
Power consumption of module electronics	at 24 V DC:	typ. 95 mA
	at 30 V DC:	typ. 120 mA
Voltage level of the sensor power supply	Min. ($U_S - 1.5$ V)	
Current consumption sensor system (L+ / Pin 1)	Max. 500 mA per port (at $T_U = 30^\circ$ C) (for UL application 400 mA)	
Short circuit/overload protection of sensor supply	Yes, per port	
Reverse polarity protection	Yes	
Operational indicator (U_S)	LED green:	18 V (+/- 1 V) < U_S < 30 V (+/- 1 V)
	LED red:	U_S < 18 V (+/- 1 V) or U_S > 30 V (+/- 1 V)
Port X03, X04 or Port X01, X02 (LiON-P 30 only)	M12 power, connector/socket, 5-pole M12 hybrid, connector/socket, 8-pole	

Table 88: Information on the power supply for the module electronics/sensors

12.4 Power supply type B ports (auxiliary supply)

Rated voltage U_{Aux}	24 V DC (SELV/PELV)
Voltage range	18 - 30 V DC
Reverse polarity protection	Yes
Operational indicator (U_S)	LED green: $18\text{ V (+/- 1 V)} < U_S < 30\text{ V (+/- 1 V)}$ LED red: $U_S < 18\text{ V (+/- 1 V)}$ or $U_S > 30\text{ V (+/- 1 V)}$ * if "Report U_{Aux} supply voltage fault" is enabled.
Port X03, X04 or Port X01, X02 (LioN-P 30 only)	M12 power, connector/socket, 5-pole M12 hybrid, connector/socket, 8-pole

Table 89: Information on the power supply for the type B ports (auxiliary supply)

12.5 IO-Link Master Ports (X1 – X8, Channel A)

Port X01 – X08 or Port X01, X08 (LioN-P 30 only)	M12 socket, 5-pin M8 socket, 5-pin
--	---

Table 90: Information on the power supply for the module electronics/sensors

12.5.1 Configured as a digital input

Input connection	Type 1 as per IEC 61131-2
Nominal input voltage	24 V DC
Input current	Typ. 3 mA
Channel type	Normally open, p-switching
Number of digital inputs	8
Status indicator	Yellow LED
Diagnosis indicator	Red LED per channel

Table 91: Information on the inputs

12.5.2 Configured as a digital output (except 0980 ESL 3x8-121)



Attention: Power is supplied to the 500 mA outputs via the U_S power supply.

Output type	Normally open, p-switching
Nominal output current per channel	500 mA (for UL application 400 mA)
Signal status "1"	Max. 500 mA
Signal status "0"	Max. 1 mA
Signal level of the outputs	
Signal status "1"	Min. ($U_S - 1$ V)
Signal status "0"	Max. 2 V
Max. output current per device	16 A (M12 Power) (for UL application 9 A) 6 A (M12 Hybrid)
Short-circuit/overload protected	yes/yes
Behavior in case of short circuit or overload	Disconnection with automatic power on
Number of digital outputs	LioN-P 30: max. 8 (Pin 4) LioN-P 60: max. 8 (Pin 4) + 4 (Pin 2)
Status indicator	LED yellow per output
Diagnosis indicator	Red LED per channel

Table 92: IO-Link Master ports configured as digital outputs

12.5.3 Configured as an IO-Link port in COM mode

IO-Link Master specification	v1.1, IEC 61131-9
Communication rates	4.8 (COM 1), 38.4 (COM 2) and 230.4 kbaud (COM 3)
Line lengths in the IO-Link Device	max. 20 m
Number of IO-Link ports (type A/type B)	8
Number of type A ports (X1, X2, X3, X4)	4
Number of type B ports (X5, X6, X7, X8)	4

Table 93: As an IO-Link port in COM mode

12.6 Digital inputs (X1 – X4, type A ports, ch. B)

Input connection	Type 1 as per IEC 61131-2
Nominal input voltage	24 V DC
Input current	Typ. 3 mA
Channel type	Normally open, p-switching
Number of digital inputs	4
Status indicator	LED white
Diagnosis indicator	Red LED per channel
Port	M12 socket, 5-pin M8 socket, 5-pin

Table 94: Digital inputs (X1 – X4, type A ports, ch. B/pin 2)

12.7 LioN-P 60: Auxiliary power supply as digital output (X5 – X8, Type B / Ch. B)

Output type	Normally open, p-switching
0980 ESL 3x8-121 Nominal output current per channel Signal status "1" Signal status "0"	1.6 A Max. 1.6 A Max. 1 mA
0980 ESL 3x9-121 Nominal output current per channel Signal status "1" Signal status "0"	2 A (for UL application 1.8 A) Max. 2 A Max. 1 mA
Signal level of the outputs Signal status "1" Signal status "0"	Min. ($U_{Aux} - 1 V$) Max. 2 V
Max. output current per device	16 A (M12 Power) (for UL application 9 A) 6 A (M12 Hybrid)
Short-circuit/overload protected Filter time in case of signal change	Yes/Yes 0 - 255 ms, default setting 80 ms
Behavior in case of short circuit or overload	Disconnection with/without automatic power on (adjustable)
Number of digital outputs	4
Status indicator	LED white per output
Diagnosis indicator	Red LED per channel

Table 95: LioN-P 60 Auxiliary power supply (X5 – X8)

12.8 LioN-P 30: U_{Aux} (X5 – X8)

Nominal output current per module	max. 4 A
Nominal output current per port	max. 4 A
Short-circuit/overload protected	yes/yes
Status indicator	LED white per output
Diagnosis indicator	Red LED per channel

Table 96: LioN-P 30 extended sensor supply (X5 – X8) type B ports

12.9 Differences between 0980 ESL 3x8-121 and 0980 ESL 3x9-121

Module type 0980 ESL 3x8-121 contains digital outputs electrically decoupled by series diodes in order to prevent unwanted reverse feeding of the sensor / actuator power supply caused by erroneous wiring.

The following block diagrams illustrate the different module types.

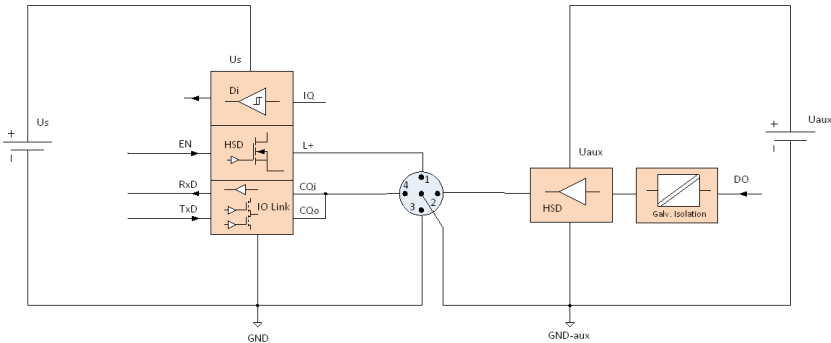

Figure 15: Block diagram Class-B Port, variant 0980 ESL xx9-xxx

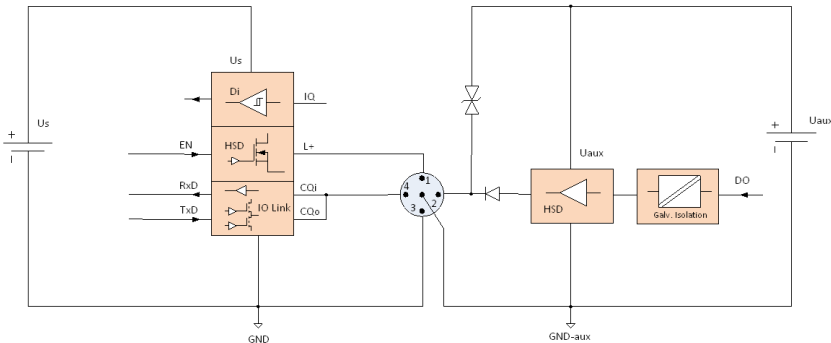

Figure 16: Block diagram Class-B Port, variant 0980 ESL xx8-xxx

12.10 LEDs

U _{Aux}	Green	Auxiliary sensor/actuator voltage $18\text{ V (+/- 1 V)} < U_{\text{Aux}} < 30\text{ V (+/- 1 V)}$
	Red*	Auxiliary sensor/actuator voltage $U_{\text{Aux}} < 18\text{ V (+/- 1 V)}$ or $U_{\text{Aux}} > 30\text{ V (+/- 1 V)}$ * if "Report U _{Aux} supply voltage fault" is enabled.
	off	None of the above conditions
U _S	Green	System/sensor voltage $18\text{ V (+/- 1 V)} < U_{\text{S}} < 30\text{ V (+/- 1 V)}$
	Red	System/sensor voltage $U_{\text{S}} < 18\text{ V (+/- 1 V)}$ or $U_{\text{S}} > 30\text{ V (+/- 1 V)}$
	off	None of the above conditions
X1 ... X8 A	Green	IO-Link COM Mode: IO-Link communication exists.
	Flashing green	IO-LinkCOM Mode: No IO-Link communication.
	Yellow	Standard-I/O Mode: Status of digital input or output on C/Q (pin 4 / channel A) line "high"
	off	None of the above conditions
X1 ... X8 B	White	Status of digital input or output on pin 2 (channel B) "high"
	Red	IO-Link COM Mode: IO-Link communication error or Overload or short circuit on C/Q (pin 4) line
	Red	All modes: Overload or short circuit on L+ (pin 1) line
	Red	SIO Mode: Overload or short circuit on C/Q (pin 4) line
	off	None of the above conditions
X01 Lnk / Act X02 Lnk / Act	Green	Ethernet connection to another subscriber. Link connection created.
	Flashing yellow	Data exchange with another subscriber.
	off	No connection to another subscriber. No link, no data exchange.

MS	Green	Device is ready for operation.
	Flashing green	Device is ready but not configured yet.
	Red	Serious error that cannot be resolved
	Flashing Red	Minor error that can be resolved Example: An incorrect or contradictory configuration is classified as a minor error
	Alternately flashing red/green	The device is performing a self-test.
	off	The device is switched off.
NS	Green	Connected: The device has at least one connection.
	Flashing green	No connection: The device has no connection. IP address exists.
	Red	Duplicate IP address: The device has detected that the assigned IP address is already being used by another device.
	Flashing Red	Connection has exceeded time limit or connection interrupted.
	Alternately flashing red/green	The device is performing a self-test
	off	The device is switched off or has not been assigned an IP address

Table 97: Information of the LED colors

13 Accessories

Information on general accessories is available on the Internet at:

<http://www.beldensolutions.com>.