

## User Manual

## Installation

### Dragonfly Enterprise Wireless Access Point

DAP645

DAP646

DAP647

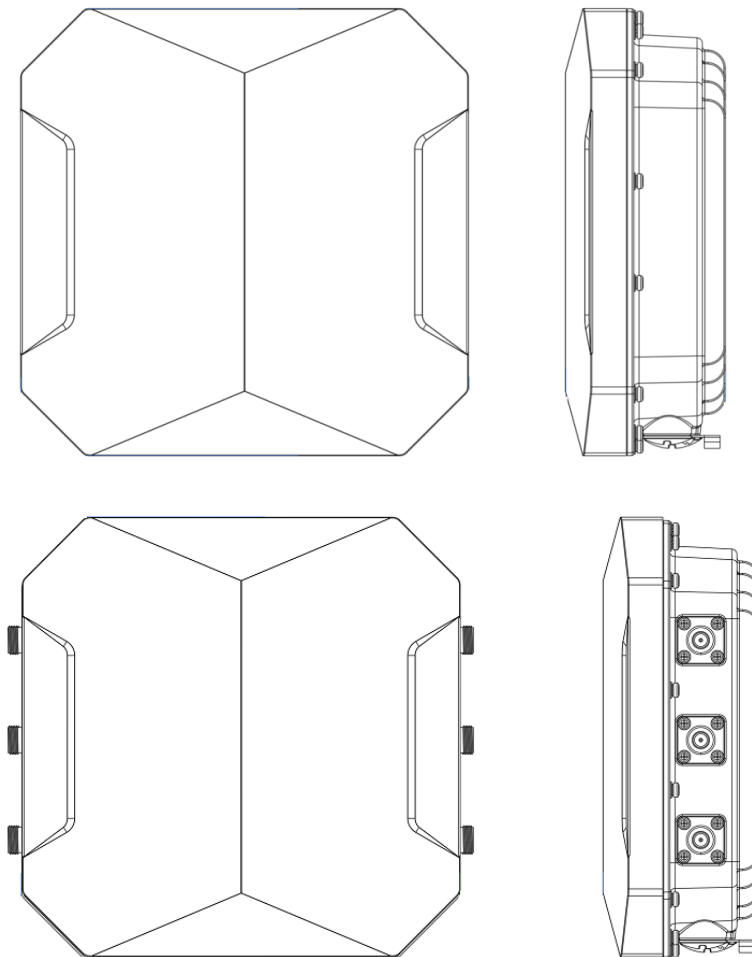

Even if not specifically stated, the copyrighted trademark names in this manual shall not be deemed free of charge in the sense of the trademark and trade name protection act and thus freely available to anyone.

© 2022 Belden Singapore Pte Ltd

Both the manual and software are protected by copyright. All rights reserved. All or any part of this manual shall be prohibited from being reproduced, copied, translated or converted into any electronic media or machine-scannable form, except in the case that you make a copy of the software for your own use.

The performance characteristics described herein shall be binding only upon the express consent of the parties at the time of signing the contract. This paper is produced by Belden within its capacity. Belden reserves the right to change the contents of this manual without prior notice. Belden does not guarantee the correctness or accuracy of the information in this manual.

Belden shall not be liable for damages caused by the use of network components or related operating software. And the conditions of use specified in the license contract are referred to in this manual.

You may access the latest version of this manual at the product website of Hirschmann IT:  
<https://catalog.belden.com>

# Contents

<b>Important information</b>	<b>5</b>
<b>Safety instructions</b>	<b>6</b>
Outdoor installation	7
Notes for countries with the following country codes:	10
Supplier's Declaration of Conformity	12
U.S. Contact Information	12
<b>About this manual</b>	<b>13</b>
<b>Key</b>	<b>13</b>
<b>1 Description</b>	<b>14</b>
1.1 General device description	14
1.2 Device name and product code	14
1.3 Device view DAP645/ DAP646	15
1.4 Device view DAP647	16
1.5 Power supply	17
1.6 Ethernet ports	17
1.7 Display elements	18
1.8 Management interfaces	20
<b>2 Installation</b>	<b>21</b>
2.1 Checking the package contents	22
2.2 Installing and grounding the device	22
2.3 Installing the antennas	42
2.4 Connecting the power supply	43
2.5 Connecting data cables	45
<b>3 First login (Password change)</b>	<b>49</b>
<b>4 Defining WLAN basic settings</b>	<b>51</b>
<b>5 Configuring the transmit power</b>	<b>52</b>
<b>6 Maintenance and service</b>	<b>54</b>

<b>7</b>	<b>Disassembly .....</b>	<b>55</b>
<b>8</b>	<b>Technical data .....</b>	<b>56</b>
8.1	General technical data .....	56
8.2	Dimension drawings.....	57
8.3	WLAN module specifications .....	58
8.4	EMC.....	60
8.5	Immunity .....	<b>Error! Bookmark not defined.</b>
8.6	Network range.....	61
8.7	Power consumption/power output .....	61
<b>9</b>	<b>Scope of delivery .....</b>	<b>62</b>
<b>10</b>	<b>Order number .....</b>	<b>62</b>
<b>11</b>	<b>Accessories .....</b>	<b>62</b>
<b>12</b>	<b>Underlying technical standards .....</b>	<b>63</b>
<b>A</b>	<b>Further support.....</b>	<b>64</b>

# Important information

**Note:** Read these instructions carefully and familiarize yourself with the device before trying to install, operate, or maintain it. The following notes may appear throughout this documentation or on the device. These notes warn of potential hazards or call attention to information that clarifies or simplifies a procedure.

## Symbol explanation



This is a general warning symbol. This symbol alerts you to potential personal injury hazards. Observe all safety notes that follow this symbol to avoid possible injury or death.



If this symbol is displayed in addition to a safety instruction of the type “Danger” or “Warning”, it means that there is a danger of electric shock and failure to observe the instructions will inevitably result in injury.



This symbol indicates the danger of hot surfaces on the device. In connection with safety instructions, non-observance of the instructions will inevitably result in injuries.



## DANGER

**DANGER** draws attention to an immediately dangerous situation, which will **inevitably** result in a serious or fatal accident if not observed.



## WARNING

**WARNING** indicates a potentially hazardous situation which, if not avoided, **could** result in death or serious injury.



## CAUTION

**CAUTION** indicates a possible danger which, if not avoided, may result in minor injuries.

## NOTICE

**NOTE** provides information about procedures that do not involve the risk of injury.

# Safety instructions



## UNCONTROLLED MACHINE ACTIONS

To avoid uncontrolled machine actions caused by data loss, configure all data transmission devices individually.

Before you start any machine, which is controlled via data transmission, ensure to complete the configuration of all data transmission devices.

**Failure to follow this instruction can result in death, serious injury, or equipment damage.**

## ▮ General safety instructions

You operate this device with electricity. Improper usage of the device entails the risk of physical injury or significant property damage. The proper and safe operation of this device depends on proper handling during transportation, proper storage and installation, and careful operation and maintenance procedures.

- Before connecting any cable, read this document, and the safety instructions and warnings.
- Operate the device with undamaged components exclusively.
- The device is free of any service components. In case of a damaged or malfunctioning device, turn off the supply voltage and return the device to Hirschmann for inspection.

## ▮ Certified usage

- Use the product only for the application cases described in the Hirschmann IT product information, including this manual.
- Operate the product only according to the technical specifications. See [“Technical data” on page 56](#).
- Connect to the product only components suitable for the requirements of the specific application case.

## Installation site requirements

“Equipment is intended for installation in Restricted Access Area”

Restricted access location:

- ▶ The location is outside the operator access area.
- ▶ The location is accessible to the service personnel even when the device is switched on.
- During the installation, make sure that you adhere to the regulations of the country in which you are operating the device.
- In ambient temperatures under  $-10\text{ °C}$  ( $+14\text{ °F}$ ), use the wiring suitable for minimum temperatures.

## Outdoor installation

Applies to device with supply voltage (PoE):

- ▶ You connect the device supply via Power over Ethernet (PoE), the circuit classification ID 1 according to IEC/EN 62368-1, Table 14 applies (max. transient voltage 1500 V, 10/700  $\mu$ s).
- ▶ The device has been approved for outdoor installation in a pollution degree 2 environment and according to outdoor enclosure.
- ▶ Observe the mounting instructions in chapter "Installing the antennas".

## Device casing

Only technicians authorized by the manufacturer are permitted to open the casing.

- Never insert pointed objects (narrow screwdrivers, wires, etc.) into the device or into the connection terminals for electric conductors. Do not touch the connection terminals.
- At ambient air temperatures  $> +60$  °C ( $+140$  °F):  
The surfaces of the device housing may become hot. Avoid touching the device while it is operating.

### □ Equipment usage

Only instructed or skilled person allowed to use the equipment (no ordinary person allowed).

### □ Qualification requirements for personnel

- Only allow qualified personnel to work on the device.  
Qualified personnel have the following characteristics:
  - ▶ Qualified personnel are properly trained. Training as well as practical knowledge and experience make up their qualifications. This is the prerequisite for grounding and labeling circuits, devices, and systems in accordance with current standards in safety technology.
  - ▶ Qualified personnel are aware of the dangers that exist in their work.
  - ▶ Qualified personnel are familiar with appropriate measures against these hazards in order to reduce the risk for themselves and others.
  - ▶ Qualified personnel receive training on a regular basis.

### □ National and international safety regulations

- Verify that the electrical installation meets local or nationally applicable safety regulations.

## Grounding the device

Grounding the device is by means of a separate protective ground connection on the device.

- Ground the device before connecting any other cables.
- Disconnect the grounding only after disconnecting all other cables. The overall shield of a connected shielded twisted pair cable is connected to the ground connection on the metal housing as a conductor.

## ▮ **Lightning protection and surge protection**

Applies exclusively to devices and antennas installed outdoors:

- ▶ The installation of the device must be carried out by a lightning protection professional in accordance with valid standards (such as IEC 62305 / DIN EN 62305 (VDE 0185-305), and in accordance with the lightning protection procedures recognized and proven for the application and the environment.
- Refer to the information in the “WLAN Outdoor Guide” on “Lightning protection and surge protection”.  
The manual is available for download on the Internet:  
<https://www.doc.hirschmann.com>
- Ensure that the lightning protection professional installs lightning protection devices (for example lightning conductors) to protect antennas installed outdoors.
- Ensure that the lightning protection professional takes appropriate lightning protection measures that mitigate the effects of lightning strikes.



## ▮ **CE marking**

The labeled devices comply with the regulations contained in the following European directive(s):

2011/65/EU and 2015/863/EU (RoHS)

Directive of the European Parliament and of the Council on the restriction of the use of certain hazardous substances in electrical and electronic equipment.

2014/53/EU (RED)

Directive of the European Parliament and of the council on the harmonization of the laws of the Member States relating to the making available on the market of radio equipment.

**CE** This product may be operated in all EU (European Union) countries under the condition that it has been configured correctly.

In accordance with the above-named EU directive(s), the EU conformity declaration will be available to the relevant authorities at the following address:

Hirschmann Automation and Control GmbH  
Stuttgarter Str. 45-51  
72654 Neckartenzlingen  
Germany

You find the EU conformity declaration as PDF file for downloading on the Internet at: <https://catalog.belden.com>

The product can be used in residential areas (residential, commercial and light-industrial environments).

**Notes for countries with the following country codes:**

								
AT	BE	BG	CH	CY	CZ	DE	DK	EE
EL	ES	FI	FR	HR	HU	IE	IT	LI
LT	LU	LV	MT	NL	NO	PL	PT	RO
RS	SE	SI	SK	TR				

- ▶ The RED compliance requires compliant operation of the device in the 5 GHz band channels. Compliant operation of the device is achieved by an unchangeable determination of the country setting. To obtain RED compliance, perform the work steps described in chapter [“Obtaining compliance for operation in the European Union and in the United Kingdom \(UK\)”](#) on page 11.

## ▮ **UKCA marking**

The labeled devices comply with the following UK regulations:

- ▶ S.I. 2012 No. 3032 Restriction of the Use of Certain Hazardous Substances in Electrical and Electronical Equipment Regulations
- ▶ S.I. 2017 No. 1206 Radio Equipment Regulations



The UKCA conformity declaration will be available to the relevant authorities at the following address:

Belden UK Ltd.  
1 The Technology Centre, Station Road  
Framlingham, IP13 9EZ, United Kingdom

You find the UKCA conformity declaration as PDF file for downloading on the Internet at: <https://www.doc.hirschmann.com/certificates.html>

## ▮ **LED or laser components**

LED or LASER components according to IEC 60825-1(2014):  
CLASS 1 LED PRODUCT

## ▮ **FCC note**

### **Supplier's Declaration of Conformity 47 CFR § 2.1077 Compliance Information**

DAP645

DAP646

DAP647

### **U.S. Contact Information**

Belden – St. Louis

1 N. Brentwood Blvd. 15th Floor

St. Louis, Missouri 63105, United States

Phone: 314.854.8000

This product has been tested and found to comply with the limits for a Class A digital device pursuant to Part 15 of the FCC Rules. These limits are designed to provide reasonable protection against harmful interference when the equipment is operated in a commercial environment. This product generates, uses, and can radiate radio frequency energy and, if not installed and used in accordance with the manufacturer's instruction manual, may cause harmful interference with radio communications. Operation of this product in a residential area is likely to cause harmful interference, in which case you will be required to correct the interference at your own expense.

This device complies with Part 15 of the FCC Rules. Operation is subject to the following two conditions:

(1) This device may not cause harmful interference, and (2) this device must accept any interference received, including interference that may cause undesired operation.

**FCC Caution:** Any changes or modifications not expressly approved by the party responsible for compliance could void the user's authority to operate this equipment.

## ▮ **RF exposure warning**

This equipment complies with FCC and CE radiation exposure limits set forth for an uncontrolled environment.

This product may not be collocated or operated in conjunction with any other antenna or transmitter.

This equipment must be installed and operated in accordance with provided instructions and the antenna(s) used for this transmitter must be installed to provide a separation distance of at least 30 cm from all persons and must not be collocated or operating in conjunction with any other antenna or transmitter.

## ▮ **Recycling note**

After usage, this device must be disposed of properly as electronic waste, in accordance with the current disposal regulations of your county, state, and country.

# About this manual

The “Installation” user manual contains a device description, safety instructions, a description of the display, and the other information that you need to install the device.

Documentation mentioned in the “User Manual Installation” that is not supplied with your device as a printout can be found as PDF files for downloading on the Internet at: <https://catalog.belden.com>

## Key

The symbols used in this manual have the following meanings:

▶	Listing
□	Work step
▮	Subheading

# 1 Description

## 1.1 General device description

Hirschmann IT Dragonfly outdoor series is enterprise level Wi-Fi 6(802.11ax) certified access point including DAP645/646/647.

There are convenient options for managing the device. Manage your devices via:

- ▶ Web browser
- ▶ SSH
- ▶ Telnet

The device works without a fan.

The device complies with the degrees of protection IP67.

## 1.2 Device name and product code

The device name corresponds to the product code.

Order number	Product code	Description
942999308	DAP645-RW	Outdoor 802.11ax 4*4 MIMO AP, data rate 2.97Gbps, build-in omni-antenna; Default shipping without mounting kit.
942999312	DAP646-RW	Outdoor 802.11ax 4*4 MIMO AP, data rate 2.97Gbps, build-in directional-antenna; Default shipping without mounting kit.
942999316	DAP647-RW	Outdoor 802.11ax 4*4 MIMO AP, data rate 2.97Gbps, extended antenna with 6*N-type female connectors; Default shipping without mounting kit.

*Table 1: Device name and product code*

## 1.3 Device view DAP645/ DAP646

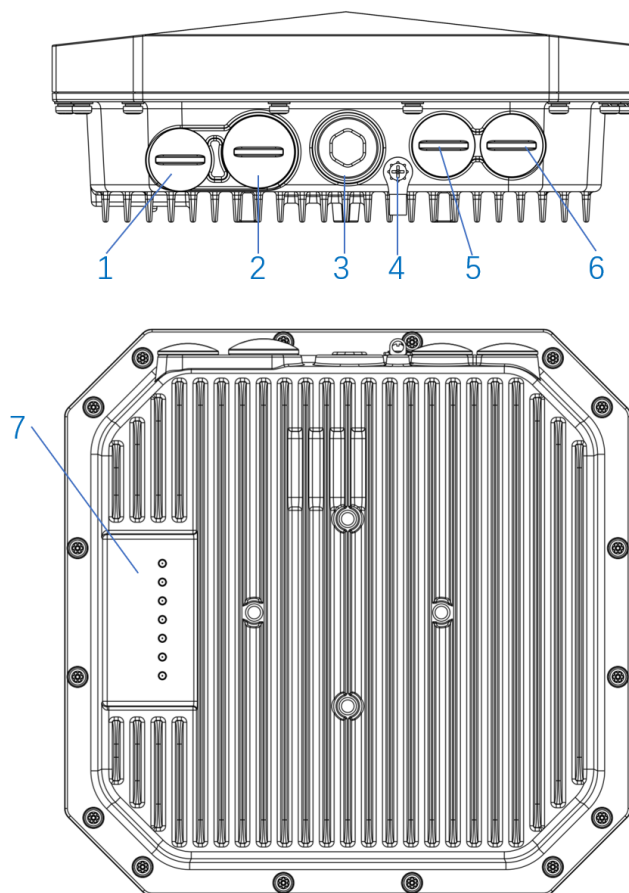

Figure 1: Device view DAP645/ DAP646

1	Reset	Factory reset. Press reset button for 5s, AP LEDs will quickly flash for 3s, then AP will restart and restore factory configurations
2	SFP	SFP module need to be purchased additionally
3	Protective vents	Don't open or remove
4	Grounding point	The grounding must be completed before powering up the AP
5	Eth0/PD	1× 10/100/1000/2500Mbps (RJ-45) port, Eth0, Power over Ethernet (PoE) 802.3bt/at compliant
6	Eth1/PSE	1× 10/100/1000Mbps (RJ-45) port, Eth1, up to 802.3at PSE in case of Eth0 802.3bt Type4 PoE input
7	Status indicators	For system and radio status

## 1.4 Device view DAP647

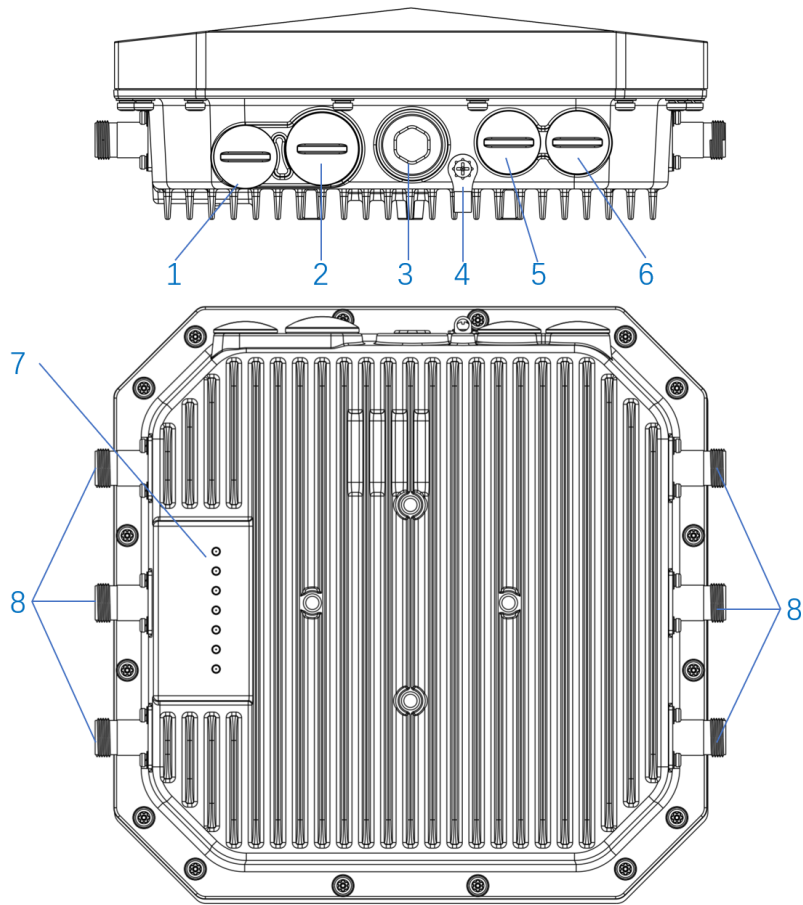

Figure 2: Device view DAP647

1	Reset	Factory reset. Press reset button for 5s, AP LEDs will quickly flash for 3s, then AP will restart and restore factory configurations
2	SFP	SFP module need to be purchased additionally
3	Protective vents	Don't open or remove
4	Grounding point	The grounding must be completed before powering up the AP
5	Eth0/PD	1× 10/100/1000/2500Mbps (RJ-45) port, Eth0, Power over Ethernet (PoE) 802.3bt/at compliant
6	Eth1/PSE	1× 10/100/1000Mbps (RJ-45) port, Eth1, up to 802.3at PSE in case of Eth0 802.3bt Type4 PoE input
7	Status indicators	For system and radio status
8	Antenna terminal	6x external Type-N connectors, labeled ANT0, ANT1, ANT2, ANT3, ANT4, and ANT5



## 1.5 Power supply

You have the following options to supply your device with voltage:

### 1.5.1 Supply voltage with PoE

#### ▮ Power supply via RJ45 socket for PoE port

Your device support PD (powered device) and PSE (power sourcing equipment). Connect the device via a twisted pair cable on the PD port as power supply input, and on the PSE port as power supply output. The PoE power supply means that no separate power supply is required for your device.

## 1.6 Ethernet ports

You have the option to connect end devices or other segments to the ports of the device via twisted pair cables.

You find information on the pin assignments for making patch cables here:

[See “Pin assignments” on page 18.](#)

### 1.6.1 10/100/1000 Mbit/s PSE port

This port is a RJ45 socket.

This port supports:

- ▶ Autocrossing (if autonegotiation is activated)
- ▶ Autonegotiation
- ▶ Autopolarity
- ▶ 10 Mbit/s half-duplex mode, 10 Mbit/s full duplex mode
- ▶ 100 Mbit/s half-duplex mode, 100 Mbit/s full duplex mode
- ▶ 1000 Mbit/s full duplex
- ▶ Power over Ethernet

The socket housing is electrically connected with the device housing.

Delivery state: Autonegotiation activated

### 1.6.2 1Gbit/s F/O port

This port is a SFP slot.

The port allows you to connect network components according to IEEE 802.3.

This port supports:

- ▶ Full duplex
- ▶ Delivery status
- ▶ 1 Gbit/s full duplex when 1 Gbit Ethernet SFP transceiver is used.

### 1.6.3 10/100/1000/2500 Mbit/s PD port

This port is a RJ45 socket.

This port supports:

- ▶ Autocrossing (if autonegotiation is activated)

- ▶ Autonegotiation
- ▶ Autopolarity
- ▶ 10 Mbit/s half-duplex mode, 10 Mbit/s full duplex mode
- ▶ 100 Mbit/s half-duplex mode, 100 Mbit/s full duplex mode
- ▶ 1000 Mbit/s full duplex
- ▶ 2500 Mbit/s full duplex
- ▶ Power over Ethernet

The socket housing is electrically connected with the device housing.

Delivery state: Autonegotiation activated

The PoE power is supplied via the wire pairs transmitting the signal (phantom voltage).

### 1.6.4 Pin assignments

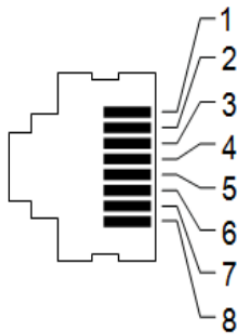
Connector	Pin	Signal Name	PoE
	1	RJ45_DA+	PoE-
	2	RJ45_DA-	PoE-
	3	RJ45_DB+	PoE+
	4	RJ45_DC+	PoE+
	5	RJ45_DC-	PoE+
	6	RJ45_DB-	PoE+
	7	RJ45_DD+	PoE-
	8	RJ45_DD-	PoE-

## 1.7 Display elements

After the supply voltage is set up, the Software starts and initializes the device. Afterwards, the device performs a self-test. During this process, various LEDs light up.

### 1.7.1 LED Indicators

LED Indicator for DAP645/ DAP646/ DAP647

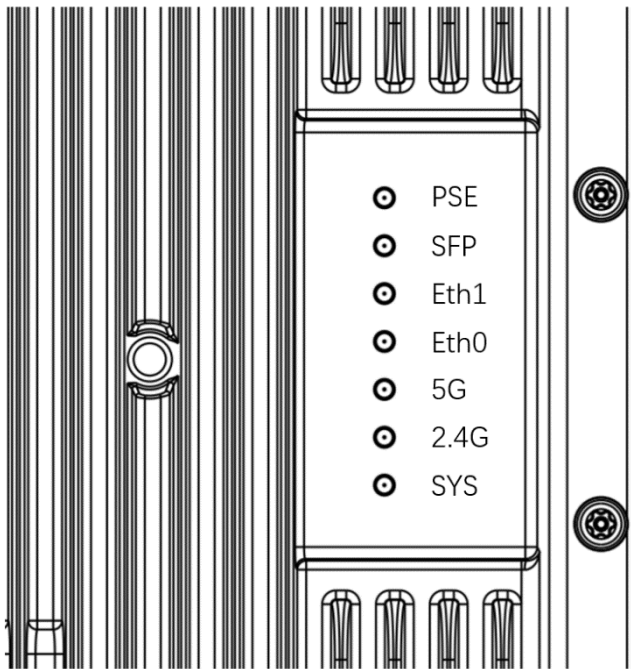

Lights	Activity	Meaning
PSE	ON	PSE enabled
SFP	ON	SFP linkup
Eth1	ON	Ethernet1 linkup
Eth0	ON	Ethernet0 linkup
5G	ON	5GHz SSID created and running
2.4G	ON	2.4GHz SSID created and running
SYS	ON	Bootloader-OS loading and system running
	Flashing	Bootloader-OS upgrading

## 1.8 Management interfaces

### 1.8.1 Reset button

The device has a reset button. The reset button is located behind a screwable IP67 protection cap.

Press reset button for 5s, LED will quickly flash for 3s, then the device will restart and restore factory configurations

**Prerequisite:** Keep the working area dry and clean when you are carrying out a reset.

After pressing the reset button, replace the protection cap. Degrees of protection IP67 are only achieved when the protection cap is closed.

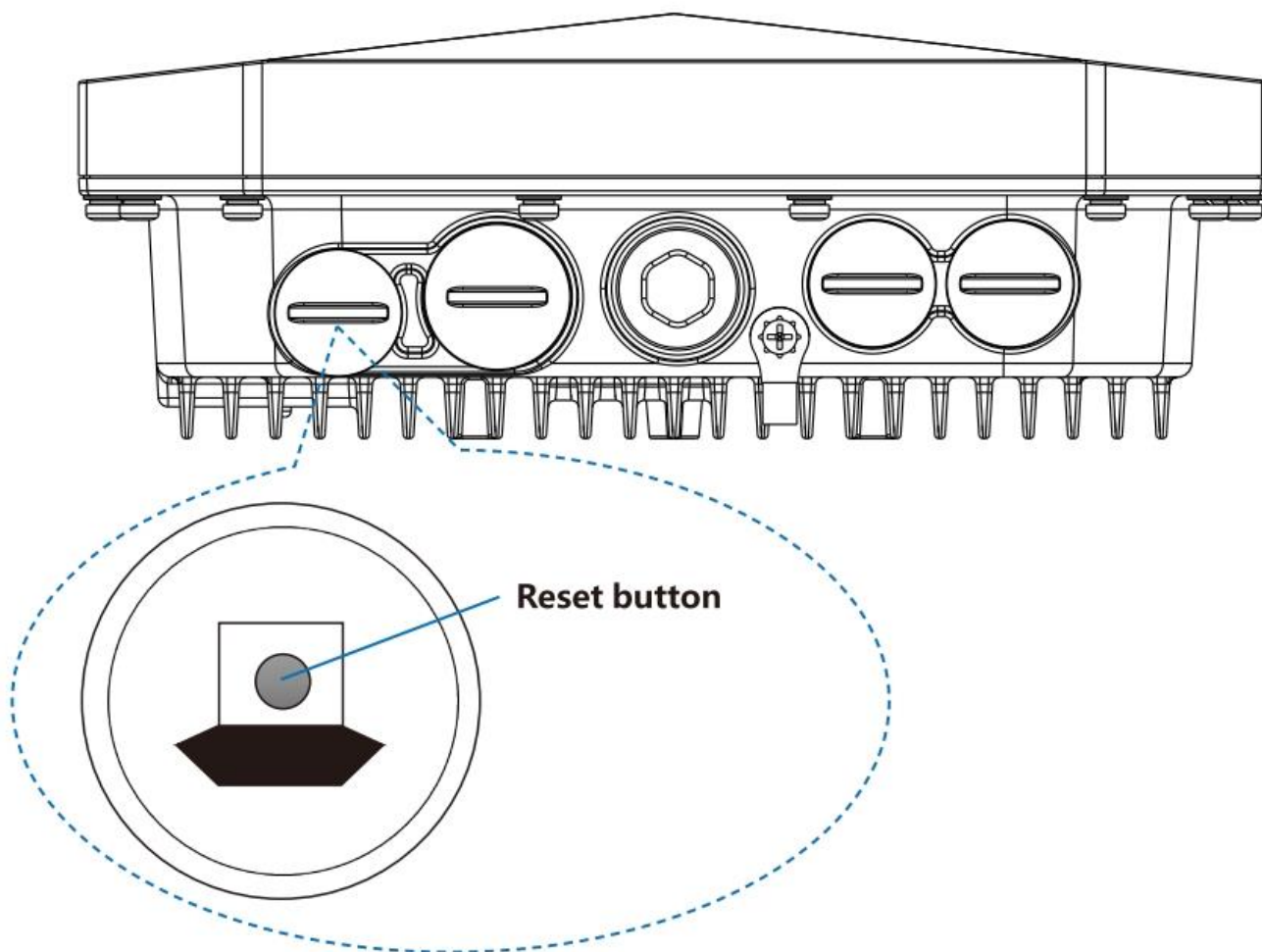

## 2 Installation

### **WARNING**

#### **ELECTRIC SHOCK**

Exclusively install this device in a restricted access location, to which maintenance staff have exclusive access. Install the device in such a way that it is protected against mechanical forces in the area of the power supply.

**Failure to follow this instruction can result in death, serious injury or damage of the equipment.**

These devices are developed for use in commercial environments.

At the time of delivery, the device is ready for operation.

On delivery, the device is ready for operation.

To protect the exposed uninstalled contacts of the components from dirt, connect the individual system components in a dry and clean working area. The device fulfills the protection class IP67 under the following conditions, exclusively:

- ▶ All the connectors and cables connected also fulfill protection class IP67.
- ▶ All the unused connections and ports are sealed with the appropriate protection screws.
- ▶ The protection screws that are available as accessories comply with degrees of protection IP67.

Applies to device with PoE

The device has been approved for outdoor installation in a pollution degree 2 environment and according to outdoor enclosure.

To install the device, perform the following work steps:

- ▶ [Checking the package contents](#)
- ▶ [Installing and grounding the device](#)
- ▶ [Installing the antennas](#)
- ▶ [Connecting the power supply](#)
- ▶ [Connecting data cables](#)

## 2.1 Checking the package contents

- According to the device variant, check whether the package contains all items listed in the scope of delivery:  
“[Scope of delivery on page 62](#)”

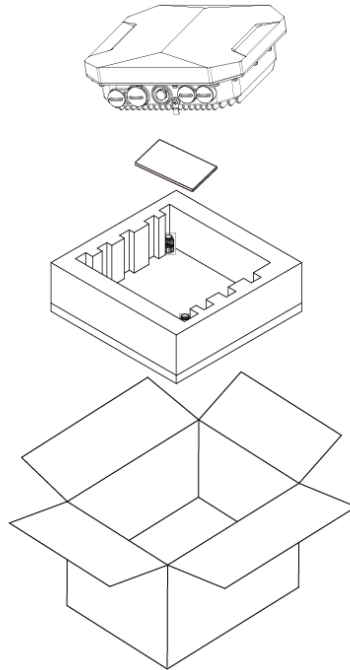

- Check the individual parts for transport damage.

## 2.2 Installing and grounding the device









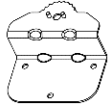
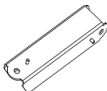
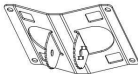

### 2.2.1 Installation for DAP645

#### 2.2.1.1 Pre-Installation Checklist

Before installing your DAP645, be sure that you have the materials and tools listed below:

- AP-MNT-OUT-H mounting kit (To be ordered separately. It contains some parts. Please refer to the mounting kit packing list for details).
- IEEE 802.3bt/at compliant PoE source.  
If needs to support PSE function on Eth1, it requires IEEE 802.3bt PoE source.
- CAT5e or better UTP cable of required length and RJ45 connector.
- Optional: SFP module and fiber-optic cable (outdoor G.657 fiber-optic cable suggested), with additional SFP cable gland (To be ordered separately) are needed in case of SFP uplink.
- Grounding wire #8AWG of required length.







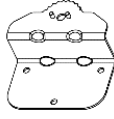
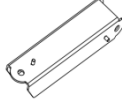

- Tools:
  - Ratchet
  - Hexagon sockets
  - Screwdriver
  - Rotary hammer
  - Percussion bit  $\Phi 8$
  - Ratchet Crimping Plier for non-insulated termina
  - Crimping Tool for RJ45 Modular Plug
  - Ethernet cable tester.
  - Heat shrinkable tube
  - Heat gun
  - Fiber melt machine (Optional)

Item	Description	Graphics	Qty
D1	Mounting bracket (D1)		1
D2	Mounting bracket (D2)		1
D3	Mounting bracket (D3)		1
D4	Spacing tube		1
D5	Screw bolt M8 x 65		1
D6	Screw bolt M8 x 25		1
D7	Screw bolt M6 x 12		3
D8	Spring washer $\Phi 8$		2
D9	Spring washer $\Phi 6$		3
D10	Screw nut M8		2
D11	Locknut M8		2
D12	Hose clamp (102-152 mm)		2
D13	Expansion bolt M6x60		4

## 2.2.1.2 Using the AP-MNT-OUT-H Mounting Kits

2.2.1.2.1 Assembling Mounting bracket (D2) with bracket (D1) and bracket (D3) to get Mounting kit (E)

### 2.2.1.2.1.1 Materials Preparation

Item	Description	Graphics	Qty
D1	Mounting bracket (D1)		1
D2	Mounting bracket (D2)		1
D3	Mounting bracket (D3)		1
D4	Spacing tube		1
D5	Screw bolt M8 x 65		1
D6	Screw bolt M8 x 25		1
D8	Spring washer $\Phi 8$		2
D10	Screw nut M8		2
D11	Locknut M8		2

### 2.2.1.2.1.2 Assembly Processes

Set-1: Insert the Mounting bracket (D2) into Bracket (D3) and align Mounting bolt hole (A) with Mounting bolt hole (B).

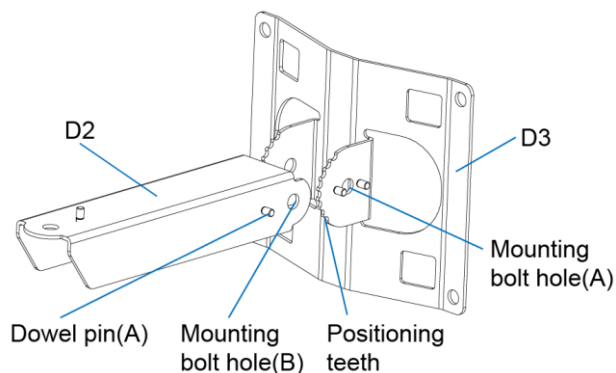

Set-2: To get a required installation angle of pitch, adjusting the Dowel pin (A) on Bracket (D2) to match up with the Positioning teeth of Mounting bracket (D3).



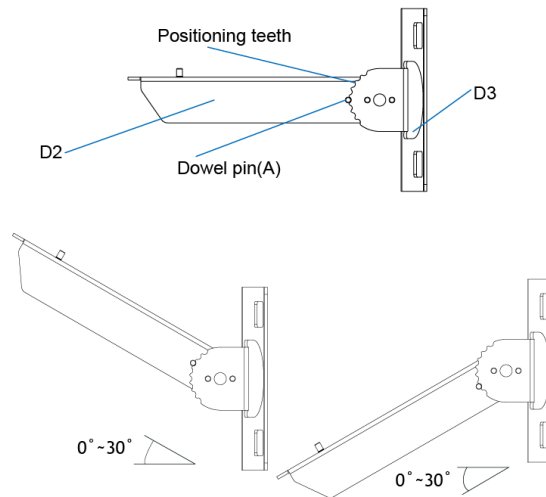

**Set-3:** Insert the Spacing tube (D4) into bracket (D2), align the hole of the tube (D4) with the Mounting bolt hole (B) of Bracket (D2).

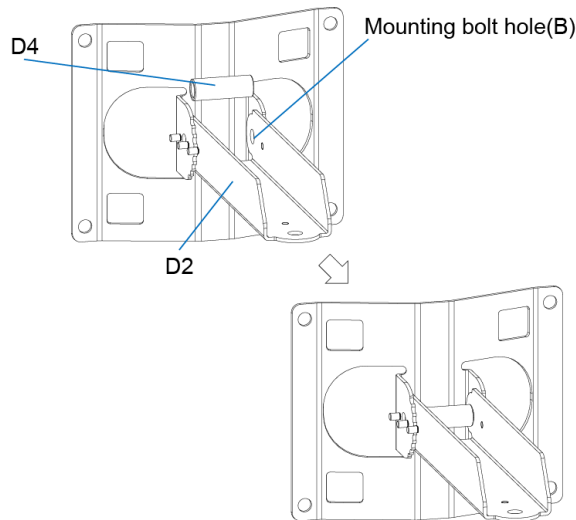

**Set-4:** From the side of Bracket (D3), where Dowel pin (B) stands, put the Screw bolt (D5) through the Mounting bolt hole (A) and stick out at the other side. Make sure the Screw bolt goes through Mounting bracket (D3), Bracket (D2) and Spacing tube (D4) in sequence. Then put a Spring washer (D8) and a Screw nut (D10) on it in sequence. Finally, tighten the Screw nut (D10) with ratchet wrench.

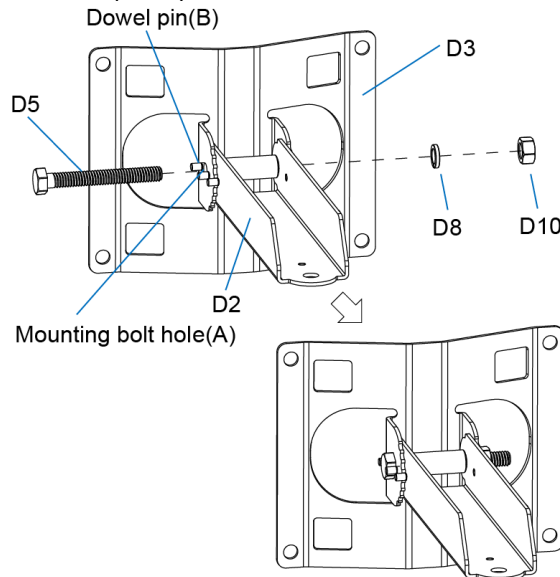

Set-5: To prevent the screw nut from loosening and for better reliability, put a Locknut (D11) on the end of the Screw bolt (D5). Then tighten it up with ratchet wrench.

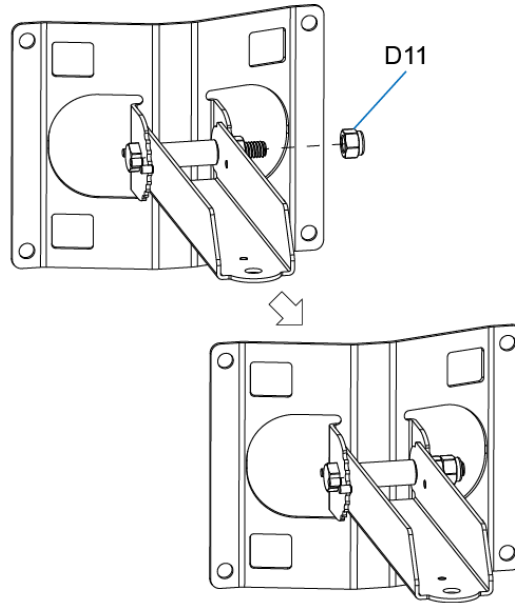

**Note: Must use a proper Ratchet wrench to tighten the Screw nut (D10) and the Locknut (D11).**

Set-6: Assembling Mounting bracket (D2) with Bracket (D1), align the Mounting bolt hole (C) with Mounting bolt hole (D).

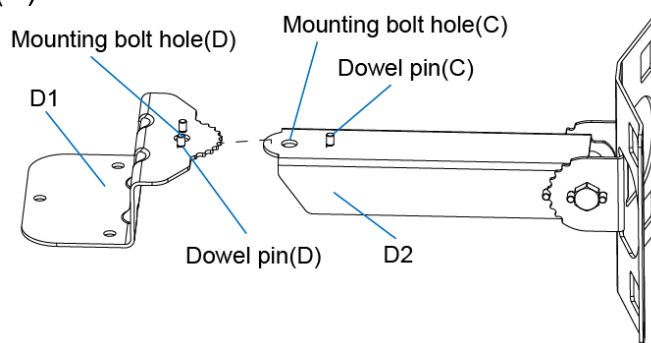

Set-7: To get a required horizontal angle, adjusting the Dowel pin (C) on Bracket (D2) to match up with the Positioning teeth of Bracket (D1).

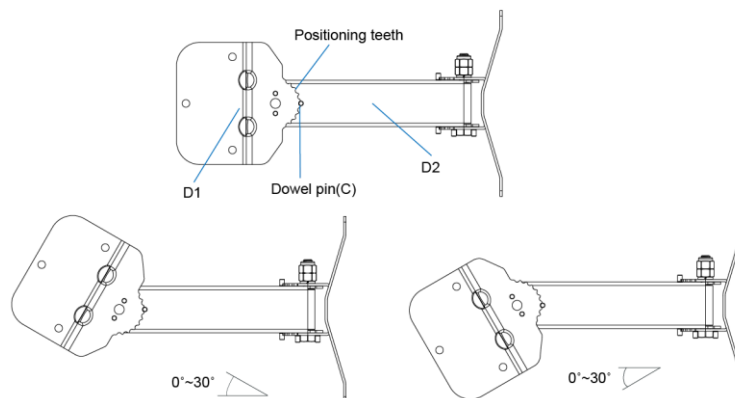

Set-8: From the side of Bracket (D1), where Dowel pin (D) stands, put the Screw bolt (D6) through the Mounting bolt hole (D) and stick out at the other side. Make sure the Screw bolt goes through Mounting bracket (D1) and Bracket (D2). Then put a Spring washer (D8) and a Screw nut (D10) on it in sequence. Finally, tighten the Screw nut (D10) with ratchet wrench.

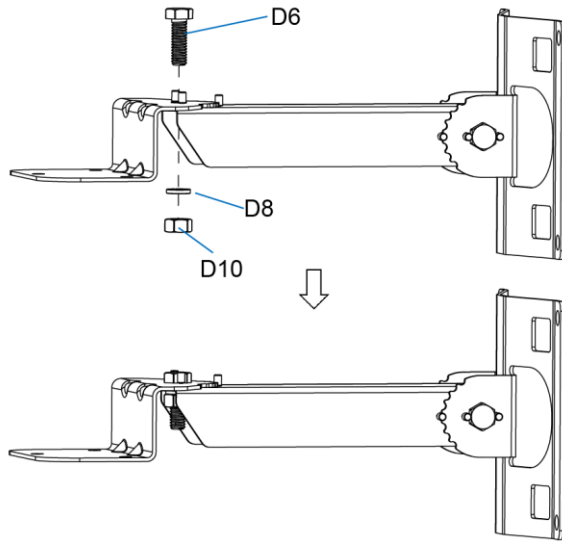

Set-9: To prevent the screw nut from loosening and for better reliability, put a Locknut (D11) on the end of the Screw bolt (D6). Then tighten it up with ratchet wrench.

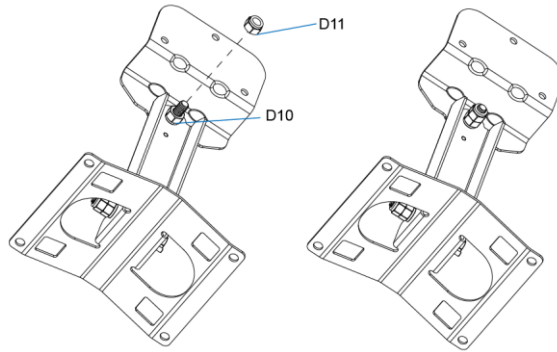

**Note: Must use a proper Ratchet wrench to tighten the Screw nut(D10) and the Locknut(D11)**

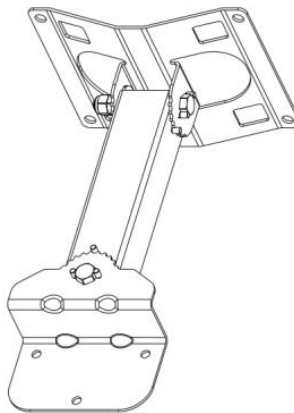

Set -10: Get Mounting kit (E).

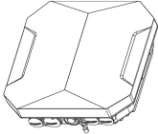

2.2.1.2.2 Assembling the AP (A) with Mounting kit (E), to get Final Assembly (F)

2.2.1.2.2.1 Materials Preparation

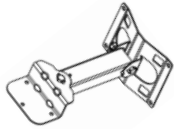
Item	Description	Graphics	Qty
A	Access Point DAP645-RW		1

E	Mounting kit(E)		1
D7	Screw bolt M6 x 12		3
D9	Spring washer Φ6		3

### 2.2.1.2.2.2 Assembly Processes

Set -11: Connecting the AP (A) with Mounting kit (E).

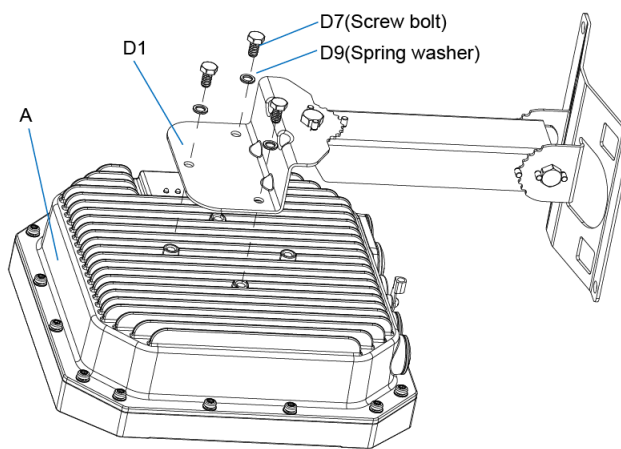

Set -12: Get Final Assembly (F)

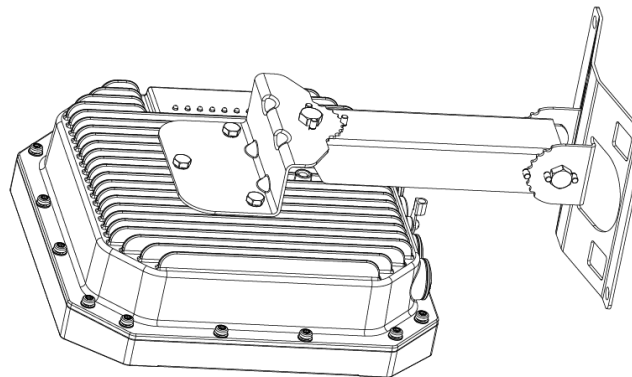



## 2.2.1.3 Mounting the AP to a Pole or a Wall

The AP is for outdoor deployment, it can be mounted to a pole or a wall by using the accessories in the mounting kit package.

### 2.2.1.3.1 Pole Mounting

#### 2.2.1.3.1.1 Materials Preparation

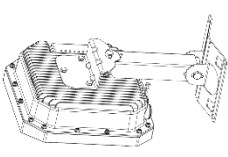
Item	Description	Graphics	Qty
------	-------------	----------	-----

F	Final Assembly (F)		1
D12	Hose clamp		2

### 2.2.1.3.1.2 Mounting Processes

Set -13: Threading the Hose clamps (D12) through the square mounting holes in Bracket (D3) separately. Considering your handedness, the direction of the screw head on the hose clamp should be determined before you thread.

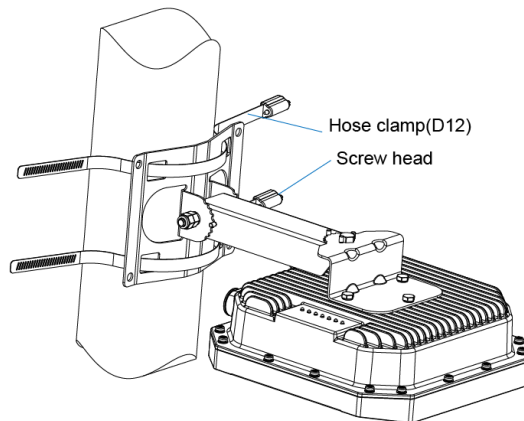

Set -14: Mounting to a pole.

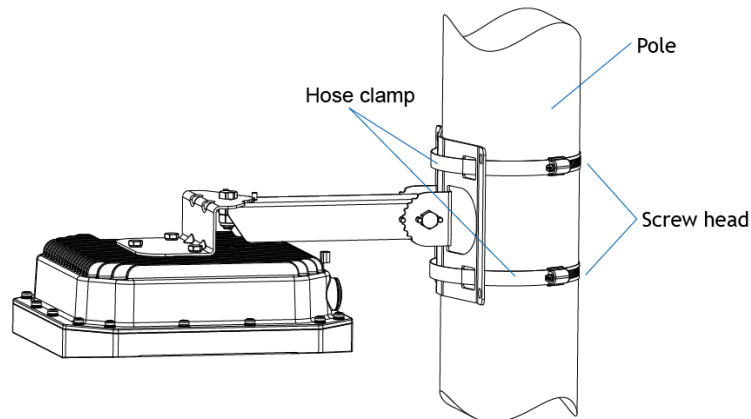

#### Caution:

- Use caution to prevent hand injury!
- For safety, the stencil area in steel belt of the Hose clamps (D12) should avoid overlapping the edge of square mounting holes on Bracket (D3).

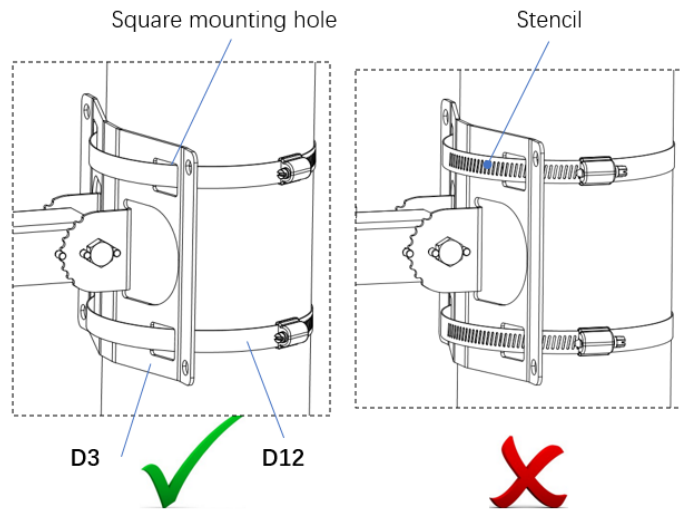

### 2.2.1.3.2 Wall Mounting

#### 2.2.1.3.2.1 Materials Preparation

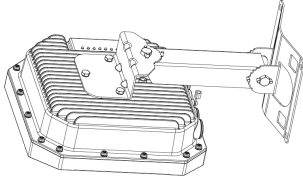
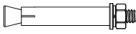
Item	Description	Graphics	Qty
F	Final Assembly (F)		1
D13	Expansion bolt M6x60		4

#### 2.2.1.3.2.2 Mounting Processes

Set -15: Draw four center marks on the wall where is planned to mount the outdoor AP. And then drill four  $\Phi 8 \times 45$  mm holes on the wall for expansion bolts.

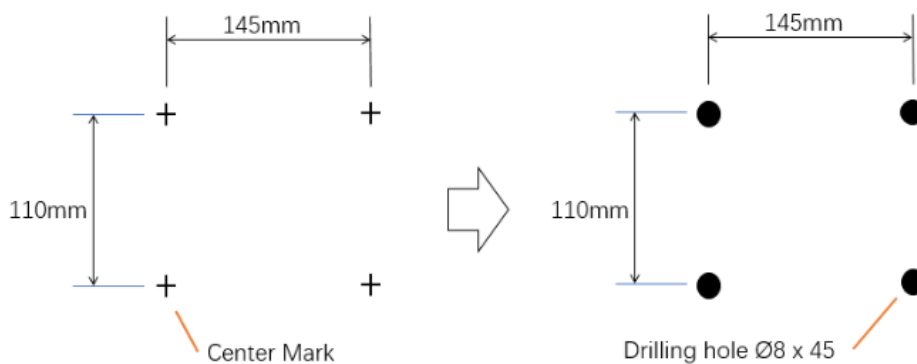

Set -16: Insert 4 Expansion bolts (D13) into the holes on the wall separately. Make sure that the end of the expansion tube should be coplanar to wall surface.

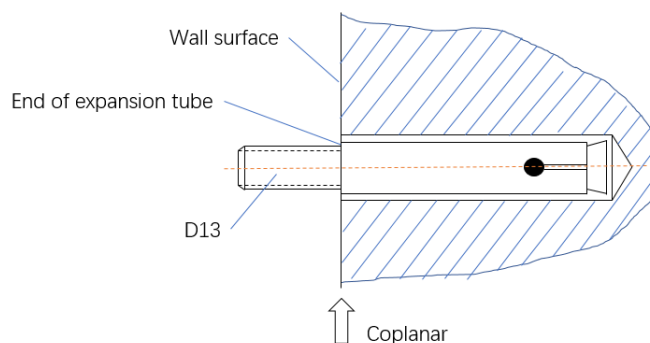

Set -17: Put the 4 expansion bolts through the 4 mounting holes in Bracket (D3). Then put a flat washer, a spring washer and a screw nut on each expansion bolt in sequence. Finally, tighten the 4 screw nuts with ratchet wrench.

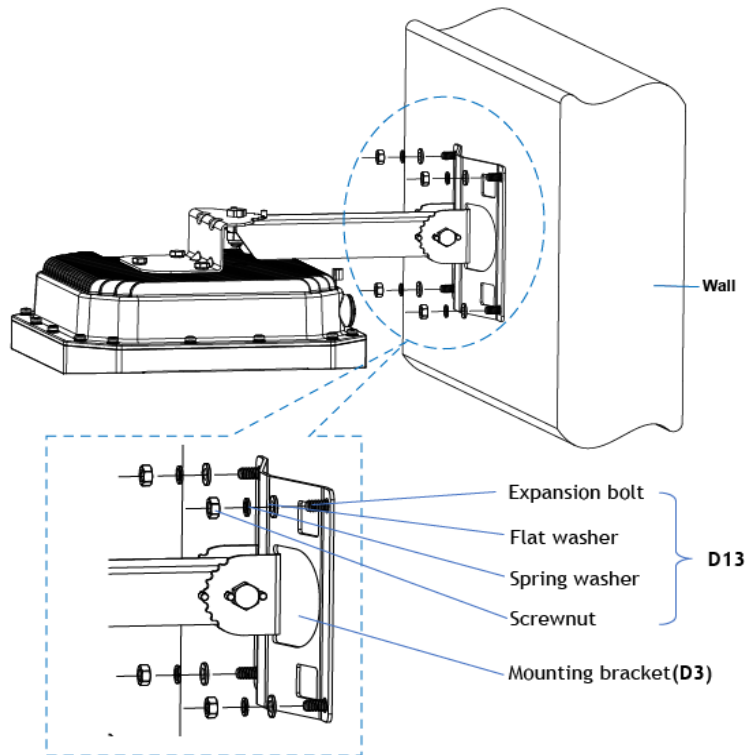













## 2.2.2 Installation for DAP646/ DAP647

### 2.2.2.1 Pre-Installation Checklist

Before installing your DAP646/DAP647, be sure that you have the materials and tools listed below:

- AP-MNT-OUT mounting kit (To be ordered separately. It contains some parts. Please refer to the mounting kit packing list for details).
- IEEE 802.3bt/at compliant PoE source.  
If needs to support PSE function on Eth1, it requires IEEE 802.3bt PoE source.
- CAT5e or better UTP cable of required length and RJ45 connector.
- Optional: SFP module and fiber-optic cable, with additional SFP cable gland (To be ordered separately) are needed in case of SFP uplink.
- Grounding wire #8AWG of required length.
- Tools:
  - Ratchet
  - Hexagon sockets
  - Screwdriver
  - Rotary hammer
  - Percussion bit  $\Phi 8$
  - Ratchet Crimping Plier for non-insulated termina
  - Crimping Tool for RJ45 Modular Plug
  - Ethernet cable tester.
  - Heat shrinkable tube
  - Heat gun
  - Fiber melt machine (Optional)

Item	Description	Graphics	Qty
D1	Mounting bracket (D1)		1
D2	Mounting bracket (D2)		1
D3	Mounting bracket (D3)		1
D4	Spacing tube		1
D5	Screw bolt M8 x 65		1
D6	Screw bolt M8 x 25		1
D7	Screw bolt M6 x 12		3
D8	Spring washer $\Phi 8$		2
D9	Spring washer $\Phi 6$		3
D10	Screw nut M8		2
D11	Locknut M8		2
D12	Hose clamp (102-152 mm)		2
D13	Expansion bolt M6x60		4



## 2.2.2.2 Using the AP-MNT-OUT Mounting Kits

2.2.2.2.1 Assembling Access Point (A) with Mounting bracket (D1), to get subassembly (E1).

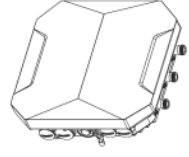
2.2.2.2.1.1 Materials Preparation

Item	Description	Graphics	Qty
A	Access Point DAP647-RW		1

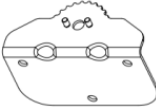
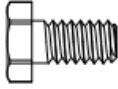

D1	Mounting bracket (D1)		1
D7	Screw bolt M6 x 12		3
D9	Spring washer Φ6		3

### 2.2.2.2.1.2 Assembly Processes

Set-1: Connecting the AP (A) with Mounting bracket (D1).

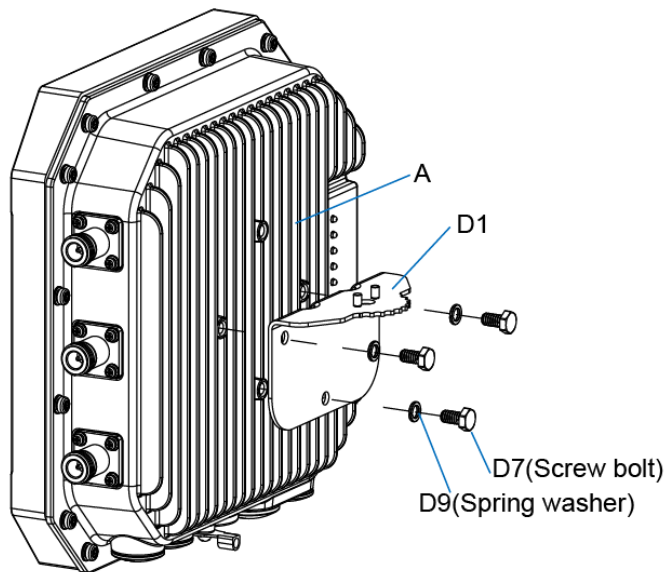



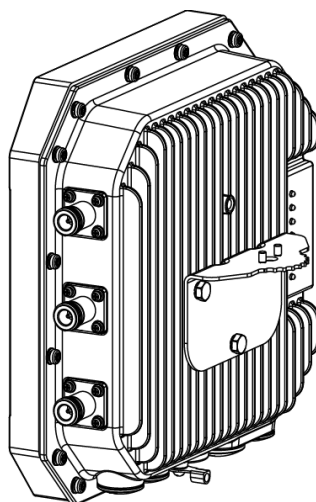



Step-2: Get Subassembly (E1).

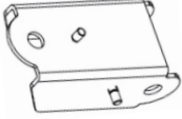
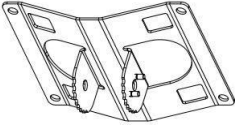

**Note: Must use a proper Ratchet wrench to tighten the Screw bolt (D7).**

2.2.2.2.1 Assembling Mounting bracket(D2) with Bracket (D3), to get subassembly (E2).

2.2.2.2.1.1 Materials Preparation

Item	Description	Graphics	Qty
D2	Mounting bracket (D2)		1
D3	Mounting bracket (D3)		1
D4	Spacing tube		1
D5	Screw bolt M8 x 65		1
D8	Spring washer $\Phi 8$		1
D10	Screw nut M8		1
D11	Locknut M8		1

2.2.2.2.1.2 Assembly Processes

Step-3: Insert the Mounting bracket (D2) into Bracket (D3) and align Mounting bolt hole (A) with Mounting bolt hole (B).

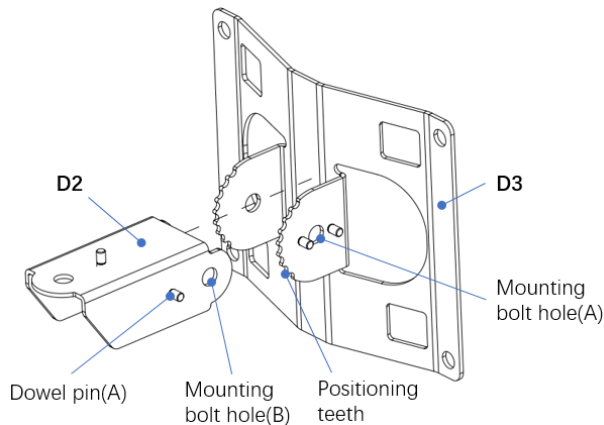

Step-4: To get a required installation angle of pitch, adjusting the Dowel pin (A) on Bracket (D2) to match up with the Positioning teeth of Mounting bracket (D3).

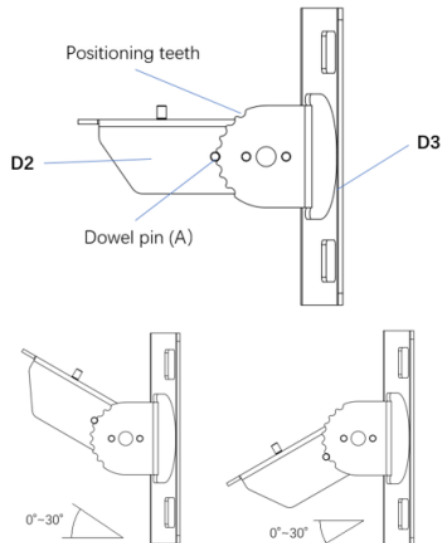

Set-5: Insert the Spacing tube (D4) into Bracket (D2), align the hole of the Tube (D4) with the Mounting bolt hole (B) of Bracket (D2).

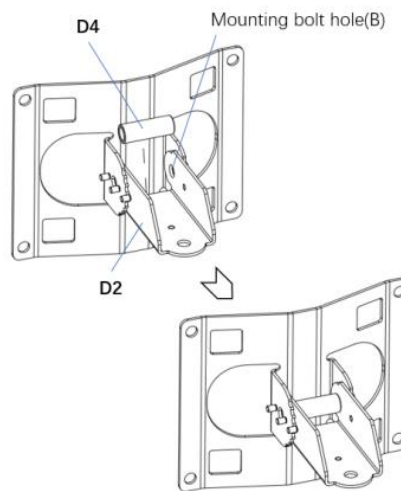

Set-6: From the side of Bracket (D3), where Dowel pin (B) stands, put the Screw bolt (D5) through the Mounting bolt hole (A) and stick out at the other side. Make sure the Screw bolt goes through Mounting bracket (D3), Bracket (D2) and Spacing tube (D4) in sequence. Then put a Spring washer (D8) and a Screw nut (D10) on it in sequence. Finally, tighten the Screw nut (D10) with ratchet wrench.

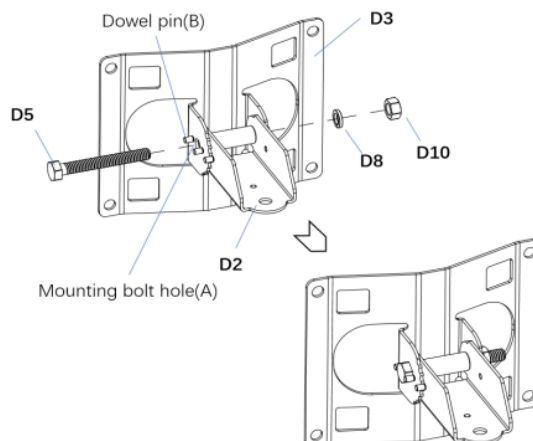

Set-7: To prevent the screw nut from loosening and for better reliability, put a Locknut (D11) on

the end of the Screw bolt (D5). Then tighten it up with ratchet wrench.

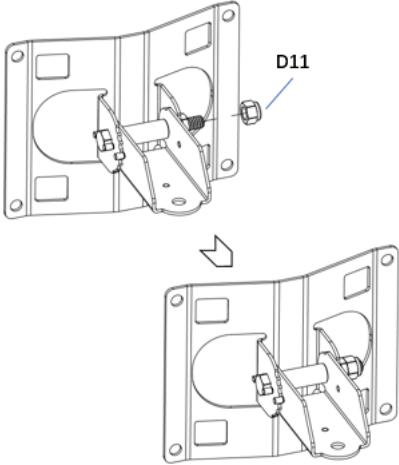



**Note: Must use a proper Ratchet wrench to tighten the Screw nut (D10) and the Locknut (D11).**

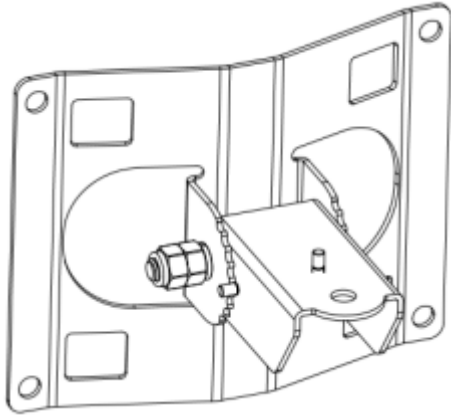

Set-8: Get Subassembly (E2)

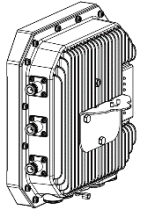
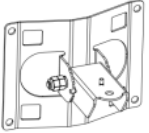
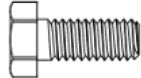

2.2.2.2.2 Assembling Subassembly (E1) with Subassembly (E2), to get Final-Assembly (F).

2.2.2.2.2.1 Materials Preparation

Item	Description	Graphics	Qty
E1	Subassembly (E1)		1
E2	Subassembly (E2)		1
D6	Screw bolt M8 x 25		1
D8	Spring washer Φ8		1

D10	Screw nut M8		1
D11	Locknut M8		1

### 2.2.2.2.2 Assembly Processes

Set-9: Overlap Subassembly (E1) to Subassembly (E2), align the Mounting bolt hole (C) with Mounting bolt hole (D).

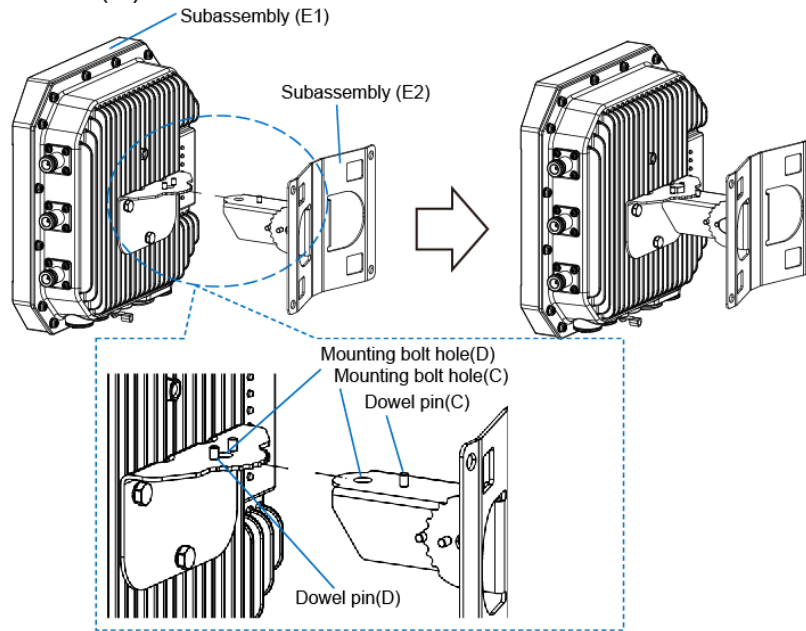

Set -10: To get a required horizontal angle, adjusting the Dowel pin (C) on Bracket (D2) to match up with the Positioning teeth of Bracket (D1).

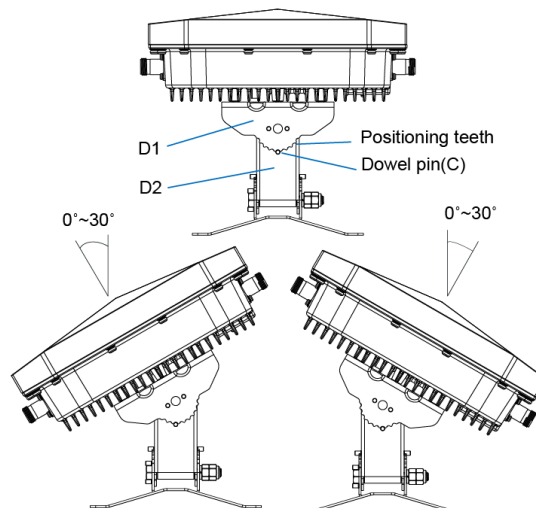

Set -11: From the side of Bracket (D1), where Dowel pin (D) stands, put the Screw bolt (D6) through the Mounting bolt hole (D) and stick out at the other side. Make sure the Screw bolt goes through Mounting bracket (D1) and Bracket (D2). Then put a Spring washer (D8) and a Screw nut (D10) on it in sequence. Finally, tighten the Screw nut (D10) with ratchet wrench.

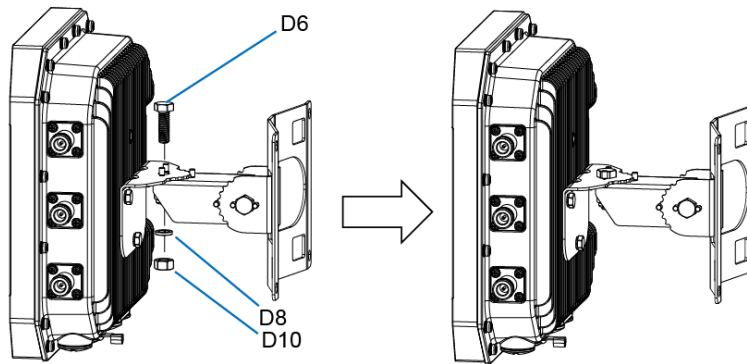

Set -12: To prevent the screw nut from loosening and for better reliability, put a Locknut (D11) on the end of the Screw bolt (D6). Then tighten it up with ratchet wrench.

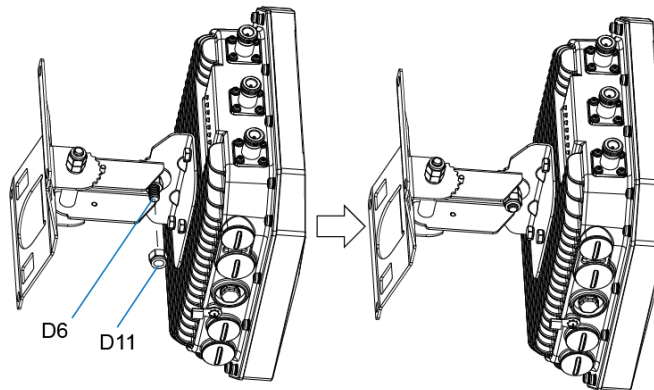

**Note: Must use a proper Ratchet wrench to tighten the Screw nut (D10) and the Locknut (D11).**

Set -13: Final assembly (F)

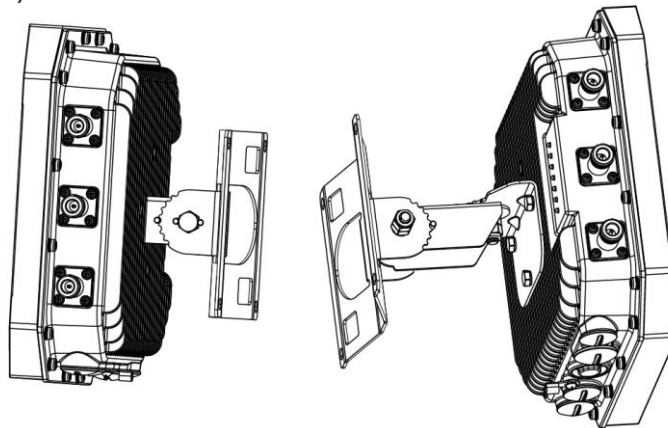



### 2.2.2.3 Mounting the AP to a Pole or a Wall

The AP is for outdoor deployment, it can be mounted to a pole or a wall by using the accessories in the mounting kit package.

#### 2.2.2.3.1 Pole Mounting

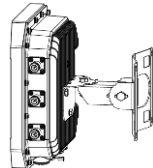
##### 2.2.2.3.1.1 Materials Preparation

Item	Description	Graphics	Qty
F	Final Assembly (F)		1

D12	Hose clamp		2
-----	------------	--	---

2.2.2.3.1.2 Assembly Processes

Set -14: Threading the Hose clamps (D12) through the square mounting holes in Bracket (D3) separately. Considering your handedness, the direction of the screw head on the hose clamp should be determined before you thread.

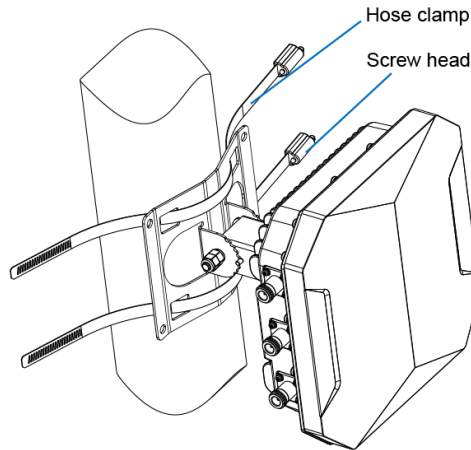

Set -15: Mounting to a pole

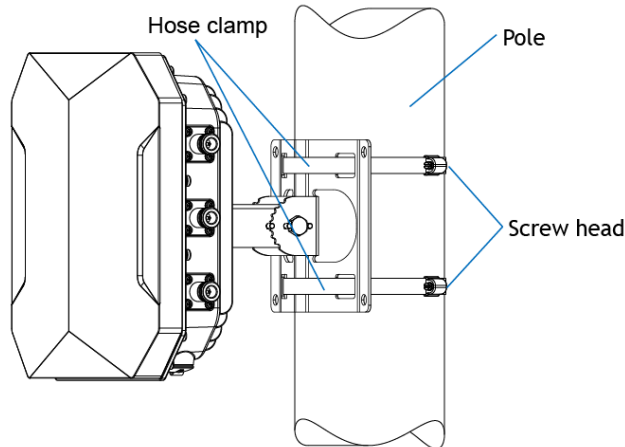

**Caution:**

Use caution to prevent hand injury!

For safety, the stencil area in steel belt of the Hose clamps (D12) should avoid overlapping the edge of square mounting holes on Bracket (D3).

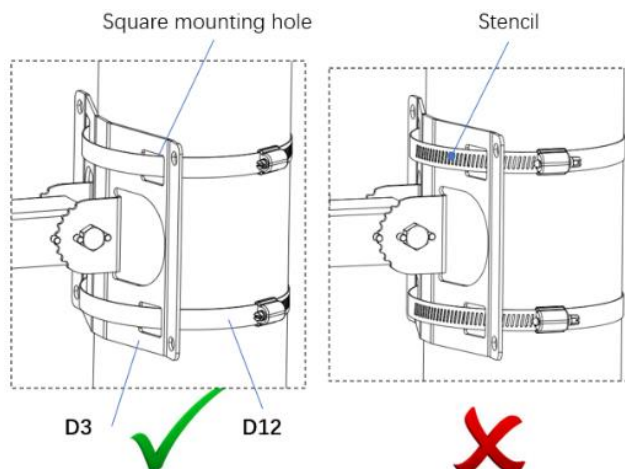

### 2.2.2.3.2 Wall Mounting

#### 2.2.2.3.2.1 Materials Preparation

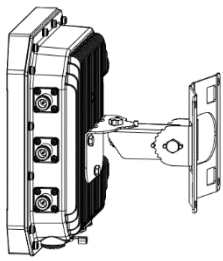
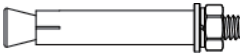
Item	Description	Graphics	Qty
F	Final Assembly (F)		1
D13	Expansion bolt M6x60		4

#### 2.2.2.3.2.2 Mounting Processes

Set -16: Draw four center marks on the wall where is planned to mount the outdoor AP. And then drill four  $\Phi 8 \times 45$  mm holes on the wall for expansion bolts.

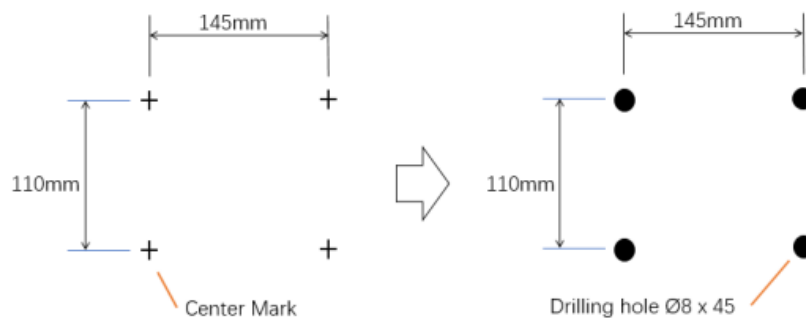

Set -17: Insert 4 Expansion bolts (D13) into the holes on the wall separately. Make sure that the end of the expansion tube should be coplanar to wall surface.

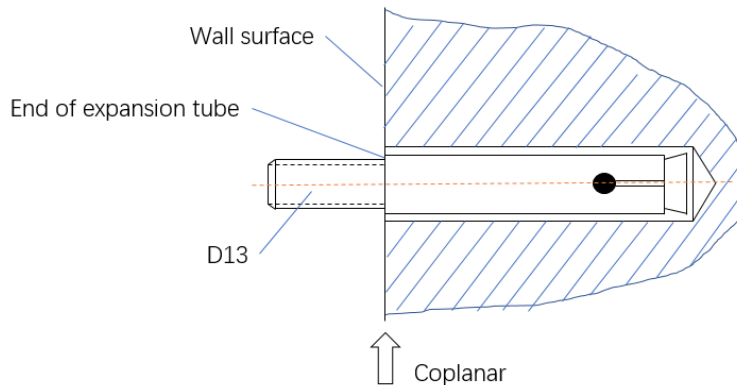

Set -18: Put the 4 expansion bolts through the 4 mounting holes in Bracket (D3). Then put a flat washer, a spring washer and a screw nut on each expansion bolt in sequence. Finally, tighten the 4 screw nuts with ratchet wrench.



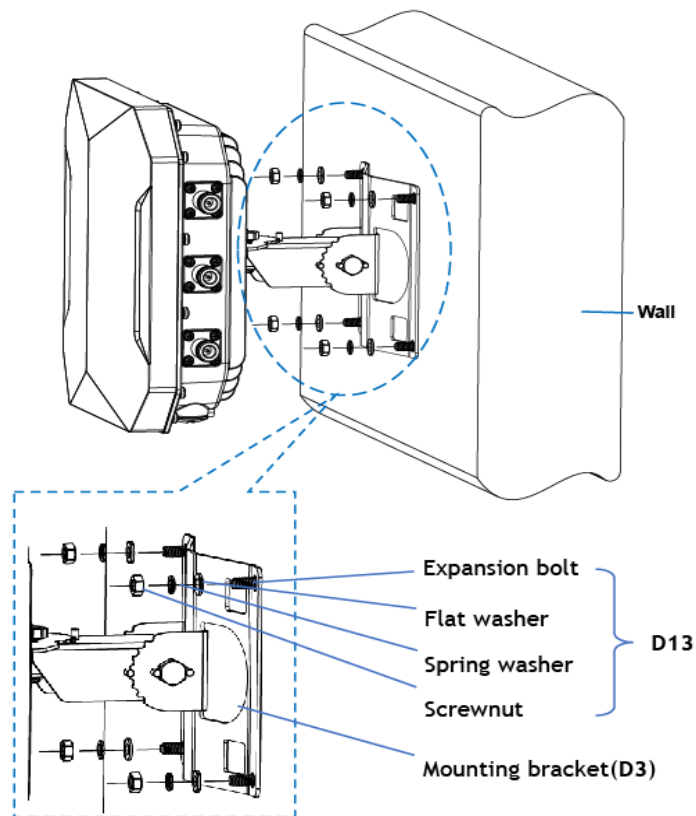

### 2.2.3 Grounding the device

## ⚠ WARNING

### ELECTRIC SHOCK

Ground the device before connecting any other cables.

**Failure to follow this instruction can result in death, serious injury, or damage of equipment.**

All devices have a protective ground connection (⊕).  
 The earthing terminal shall have permanently connected to building earth.  
 The device is grounded via the separate ground screw.

- Terminate the ground conductor between the fastening plates.
- Make sure the fastening plates cover the stripped part of the ground conductor completely.
- Tighten the grounding screw with a tightening torque of  $1.5 \text{ Nm} \pm 0.5$ .

Perform the following work steps:

- Grounding Preparation  
 Screw off the O-Terminal from the AP and keep it with the Assembled bolt.

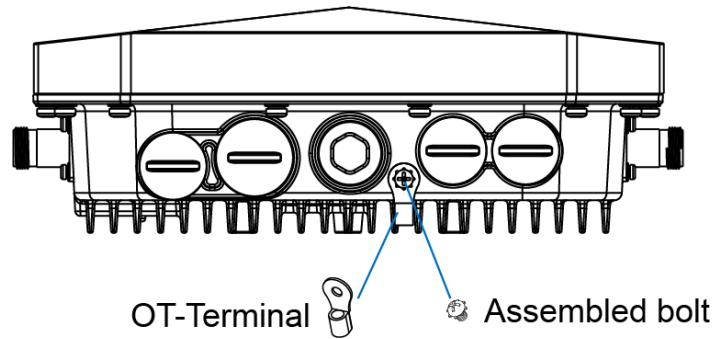

- Crimping the Grounding wire.  
Peel the cover of one end of the grounding wire and place the bare grounding wire into the O-Terminal and press firmly with the crimping pliers. A heat shrinkable tube is suggested to put on.

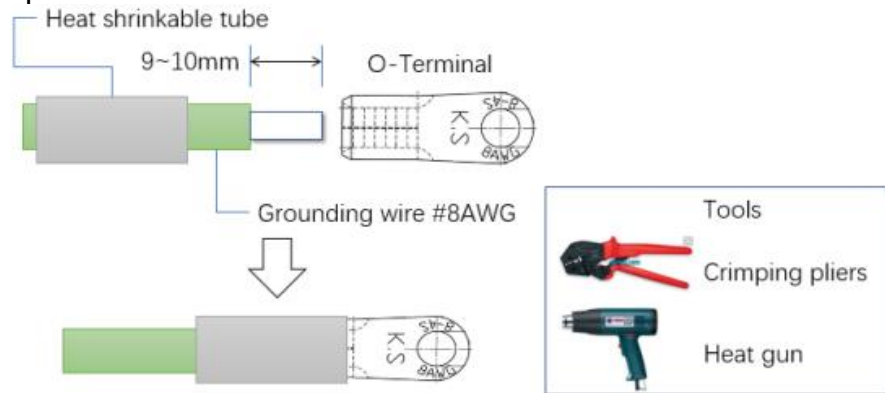

- Connecting the Grounding Wire.  
Fasten the O-Terminal to the grounding hole on the AP with the Assembled bolt, take pole mounting circumstances.

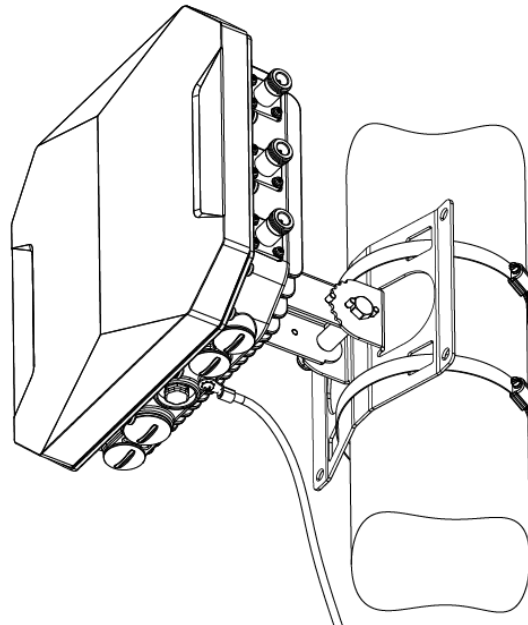

## 2.3 Installing the antennas

The device DAP647 has connections for external antennas. These connections are Type-N female sockets.

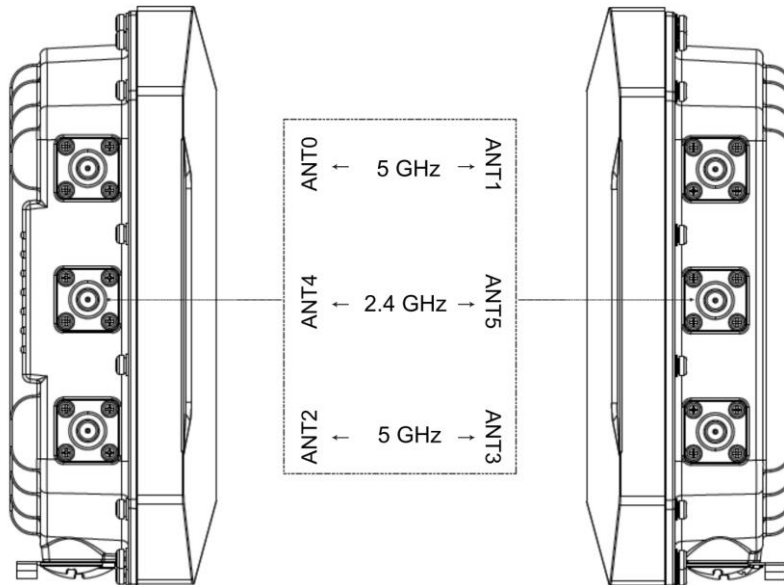

On delivery, the antenna connections are sealed with transport protection caps. Perform the following work steps:

- Remove the pre-mounted transport protection caps from the antenna connections.
- Install at least one 2.4G or 5G antenna on the radio module that you would like to use.
- Recommend using the provided 50ohm terminating resistors to seal unused sockets to avoid radio signals from one radio module being received by another radio module.

## 2.4 Connecting the power supply

### 2.4.1 Supply voltage with PoE

# NOTICE

## MATERIAL DAMAGE

In a PoE installation, use only devices that comply with the IEEE 802.3at/bt standard.

**Failure to follow this instruction can lead to equipment damage.**

You start up the device by connecting the power supply via RJ45 socket for PoE port

- Only run data links indoors (IEEE 802.3 area A).

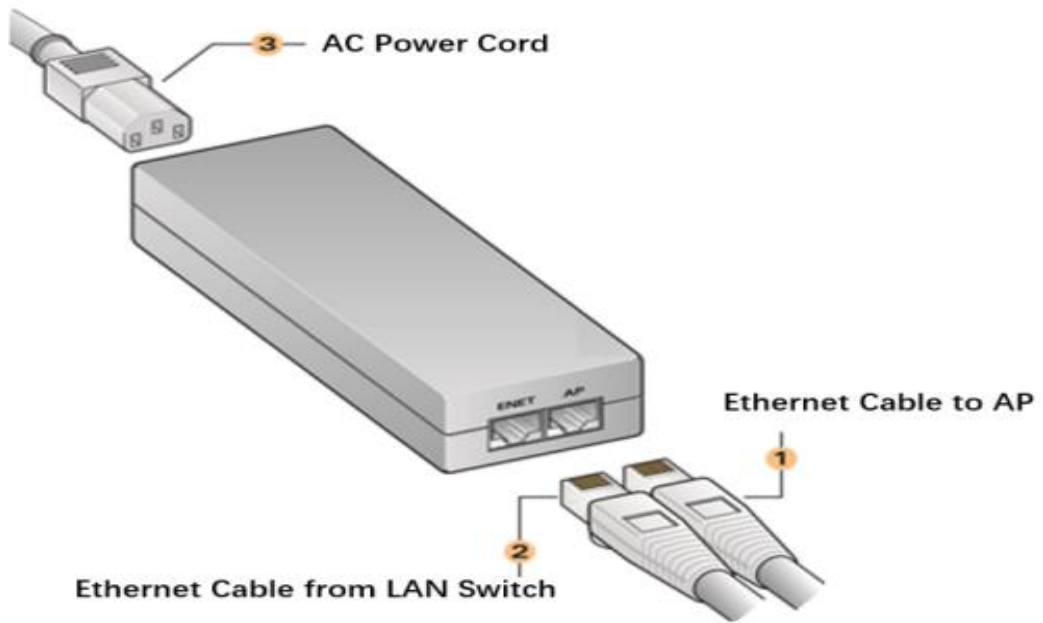

## 2.5 Connecting data cables

Note the following general recommendations for data cable connections in environments with high electrical interference levels:

- Keep the length of the data cables as short as possible.
- When using copper cables, provide a sufficient separation between power supply cables and the data cables. Ideally, install the cables in separate cable channels.
- Verify that power supply cables and data cables do not run parallel over longer distances. To reduce inductive coupling, verify that the power supply cables and data cables cross at a 90° angle.
- Use shielded data cables for gigabit transmission via copper cables, for example SF/UTP cables according to ISO/IEC 11801. Exclusively use shielded data cables to meet EMC requirements.
- Connect the data cables according to your requirements.  
[See “Ethernet ports” on page 17.](#)
- You find the prescribed tightening torque of the locking screw in chapter:  
[“General technical data” on page 56.](#)

**You can connect the cable with following steps:**

### 2.5.1 Connecting the Ethernet cable

To connect the Ethernet cable to the AP, perform the following steps using the Cable glands (B) that ships with your AP.

#### 2.5.1.1 The Cable Gland (B)

The Cable gland (B) is composed of 5 elements, which are Sealing nut (B1), Clamping ring (B2), Seals (B3), Gland body (B4) and O-ring (B5).

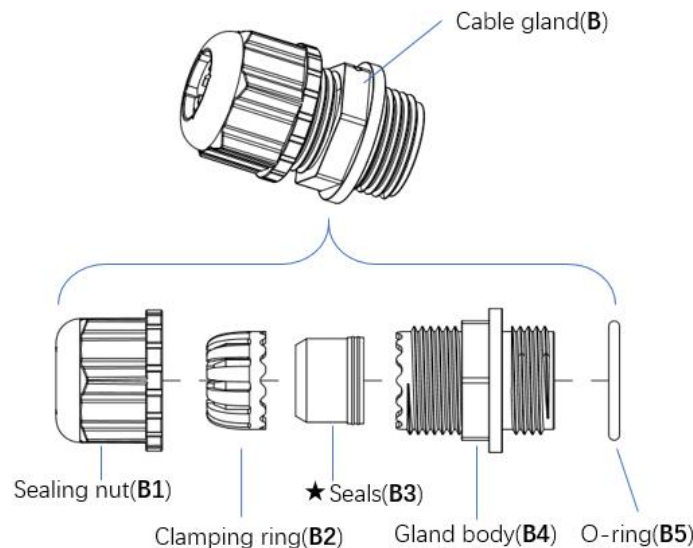

The Seals (B3) inside the Cable gland (B) by factory default is applicable for cables with 4-6mm diameter. In the cable gland kit, another seal is provided for use with cable with 6-10mm diameter.

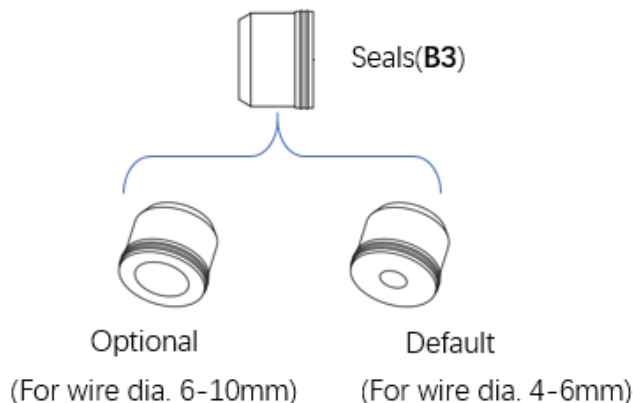

### 2.5.1.2 Crimping the Ethernet cable

The following figure shows the process of crimping Ethernet cable.

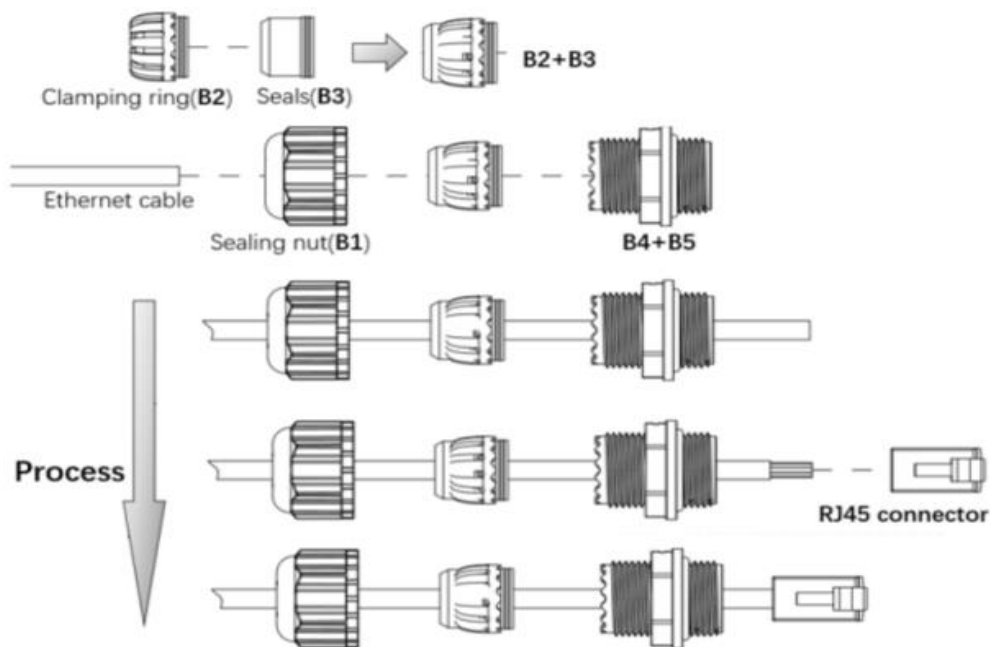

#### Caution:

Do Not peel the cover of the Ethernet cable or attach the RJ45 connector to the cable before sliding the Cable gland (B) over the cable. Failure to use the included Ethernet cable glands can lead to product issues.

### 2.5.1.3 Remove the Weatherproof Cap

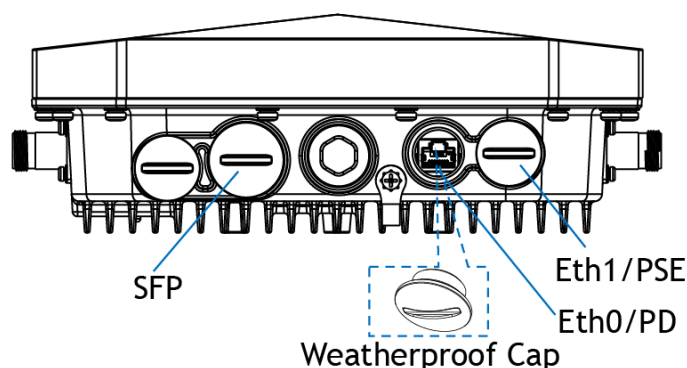

#### Note:

Keep the weatherproof caps on the AP tightly while you don't plan to use the related ports.

### 2.5.1.4 Connecting the cable

Connect the Ethernet cable, which was crimped in Step-22, to either Ethernet Port-0 or Ethernet Port-1. And then, screw the Gland body (B4+B5) onto the Ethernet port with proper wrench.

Connect the Seals with Clamping ring (B2+B3) to the Gland body (B4), and then screw the Sealing nut (B1) onto the Gland body (B4) and tighten it firmly.

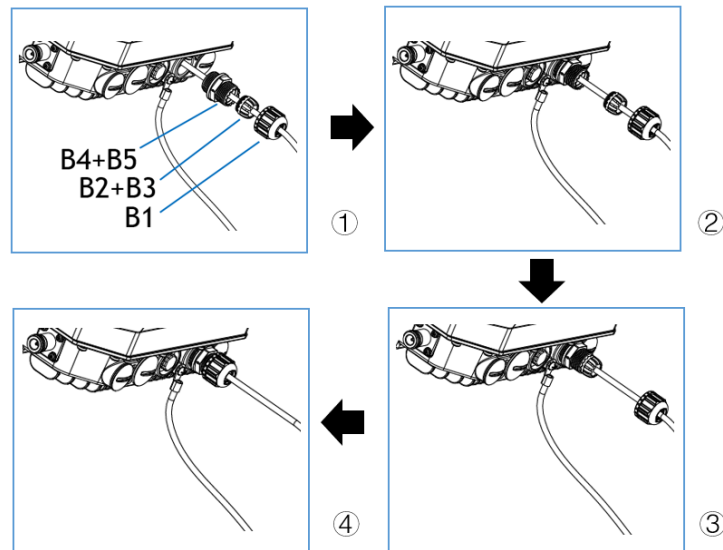

**Caution:**

Do not screw the Sealing nut (B1) onto the Gland body (B4) before connecting the RJ45 connector to the Ethernet port.

Must use a proper wrench to tighten the Gland body.

### 2.5.2 Connecting the Fiber-optic Cable

To connect the fiber-optic cable to the AP, perform the following steps.

2.5.2.1 Remove the Weatherproof Cap from the SFP port.

**Note:**

Keep the weatherproof cap on the AP tightly while you don't plan to use the port.

2.5.2.2 Insert the SFP module into the SFP port and ensure it in place.

2.5.2.3 Slide the Sealing nut, Seals, Gland body and O-ring over the cable.

**Note:**

The SFP gland is composed of 5 parts, as shown in Figure below. They are assembled and need to be disassembled before use.

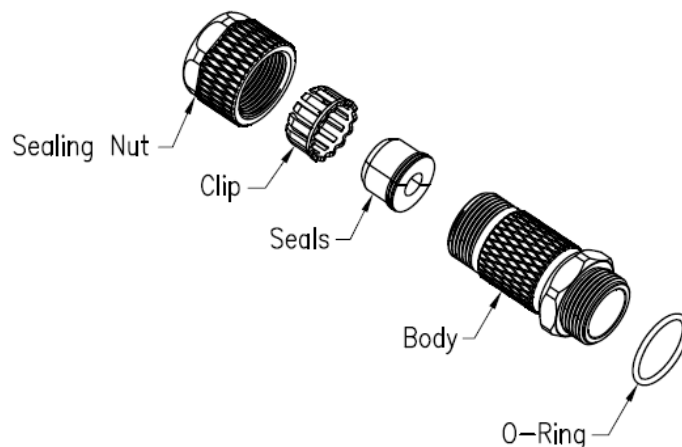

The Seals in the package is divided into two specifications (Seals 1 and Seals 2), Seals1 recommended cable diameter:  $\Phi 4.5\text{mm} \sim \Phi 6.5\text{mm}$ .

Seals 2 recommended cable diameter:  $\Phi 6.6\text{mm} \sim \Phi 8.6\text{mm}$ .

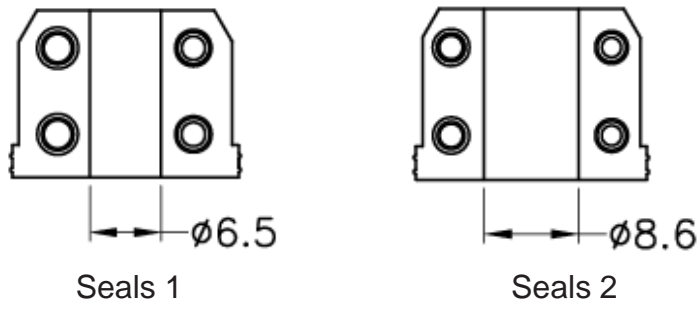

2.5.2.4 Insert the Cable through the Sealing Nut, Clip, Seals, Body And O-Ring.

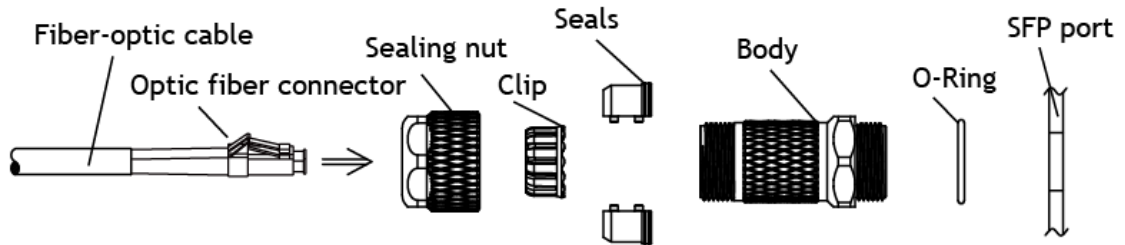

2.5.2.5 The insert Seals & Clip.

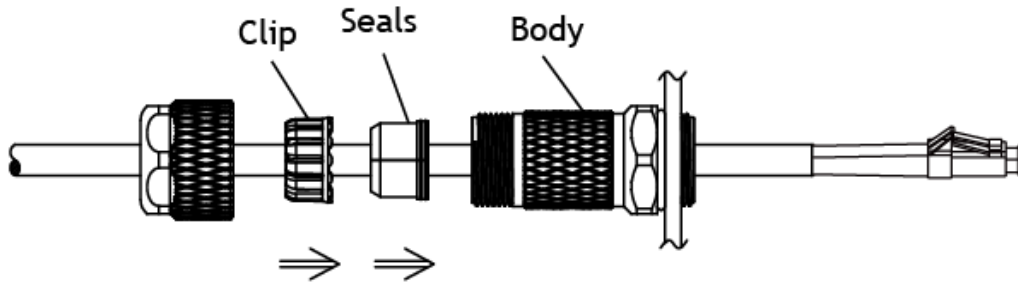

2.5.2.6 The insert sealing nut the torque force: 10~12Kgf/cm2. Assembly Finished.

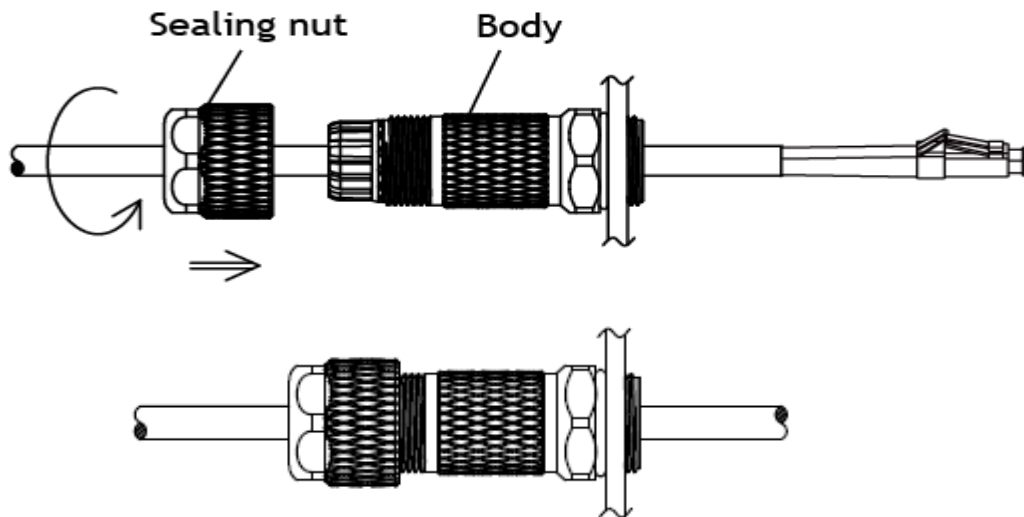



### 3 First login (Password change)

To help prevent undesired access to the device, it is imperative that you change the default password during initial setup.

Perform the following steps:

- By default, DAP will broadcast the WLAN 'mywifi-xxxx' (xxxx = the last two bytes of the AP MAC address). You can connect to 'mywifi-xxxx' and browse <http://find.dragonflyap.com:8080> to access the AP web page.

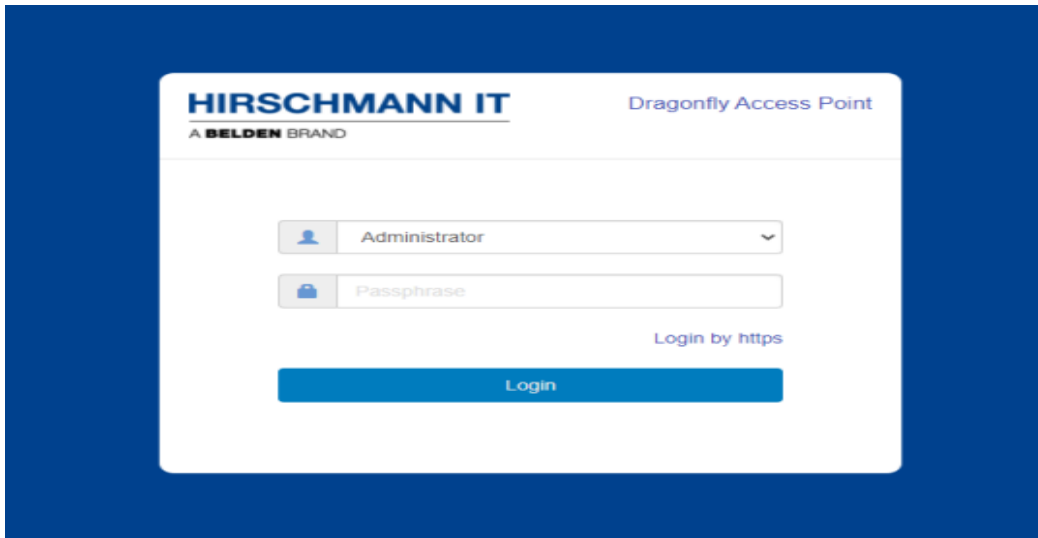

**Note:** Recommend to access AP web Page by Chrome Browser for best user experience.

- Choose Administrator and default password is admin. Login AP web page, and you can access with below figure. Select "Cluster" to cluster mode, or you can select "DAC" to DAC mode.

#### Setup Wizard

Please select management mode of the AP:

Cluster  DAC

Next

**Note:** There are three pre-configured login accounts: Administrator, Viewer and Guest Manager. You may modify the account password, but the account name isn't modifiable. Administrator can configure and check the AP status, Viewer can check the AP status ONLY, while Guest Operator can check the AP status and register accounts for portal authentication. By default, the password for all accounts is 'admin' and the wizard will guide you to modify the Administrator password upon AP login. More detailed configuration guide, please refer to DAP User Manual.

- When initially logging into an AP, a configuration wizard will pop up. The following steps show how to use the setup wizard to modify the Administrator password and create a WLAN.

## Setup Wizard

Welcome to the AP Cluster Web Manager

---The AP Cluster Management System

Back

Next

- Confirm your new password.

## Setup Wizard

Step 1/3 Change your administrator password

Password:

Confirm:

Back

Next

**Note:** *The page below will be displayed to select the country or region.*

## Setup Wizard

Step 2/3 Choose your Country or Region

Country/Region:

Albania - AL

Time Zone:

(UTC-12:00)International-Date-Line-West

Back

Next

## 4 Defining WLAN basic settings

You have the following options to define the WLAN basic settings:

- ▶ via the wired local network (LAN)
- ▶ via the wireless network (WLAN), if the WLAN encryption (for example WPA2) is set accordingly in a device with a wireless interface and in the configuration computer.

For more details, please refer to user manual.

## 5 Configuring the transmit power

You can modify the transmission power and working channel for the DAP in the RF Configuration Window, shown in below figure, by default, the working channel and transmitting power are automatically managed by Dynamic Radio Management (DRM) technology. If you want to set the channel and power values for an AP manually, you need to disable the Automatic Channel Selection (ACS) and Automatic Power Control (APC); in manual mode the AP transmits power can be adjusted in 1 dB increments

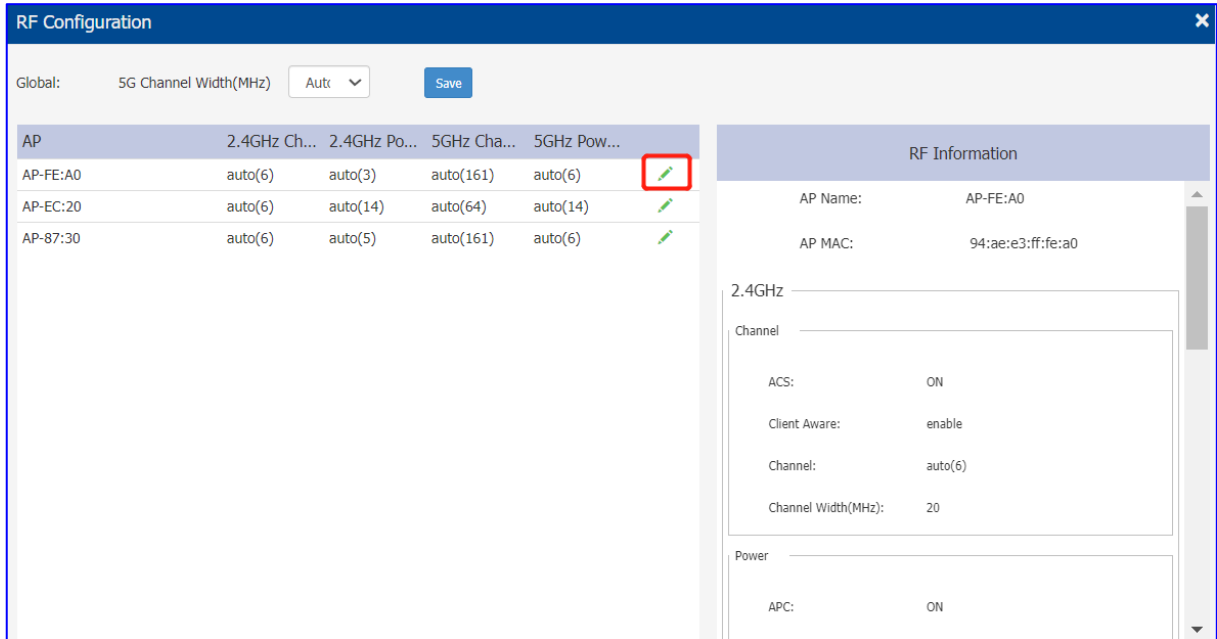

You can specify the channels list/power range applicable for auto selection, which can reduce the risk of low power transmitting or DFS channel conflict, as shown below.

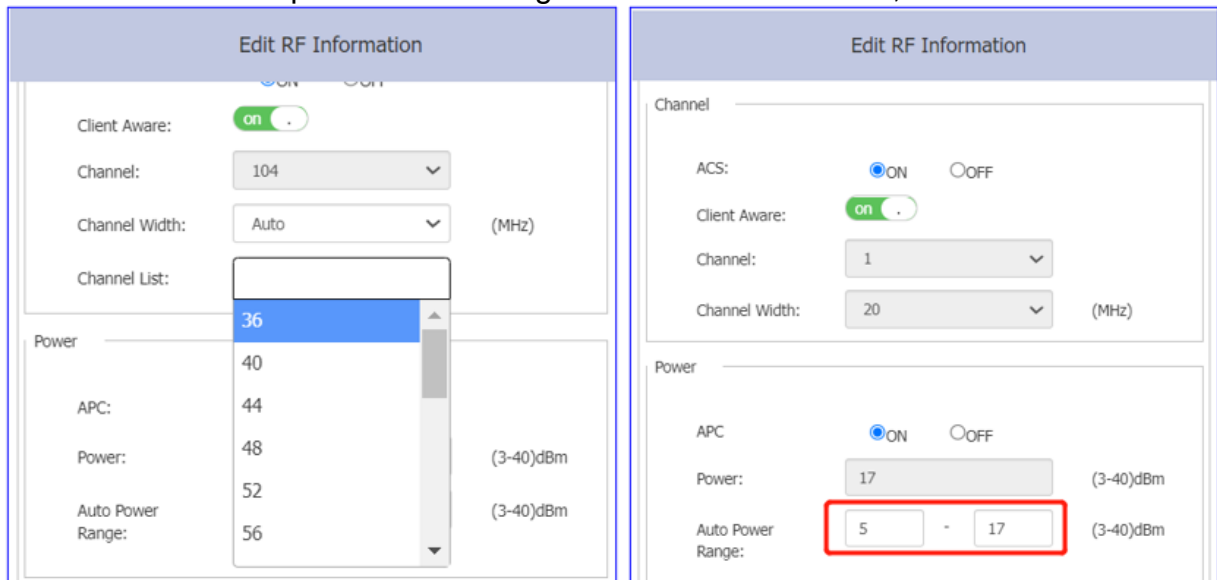

**Note:** DFS relies on the background scanning feature. To ensure the DFS is effective, make sure the background scanning is ON.

Key word specification in RF Configuration Window

Parameter	Specification
<b>Client Aware</b>	When enabled, Auto Channel Selection does not change channels for DAPs with connected clients, except for high-priority events such as RADAR detected. If "Client Aware" is Disabled, the DAP may change to a more optimal channel, which may temporarily disrupt current client traffic.
<b>Short GI</b>	<p>Enable/Disable Short Guard Interval. In IEEE 802.11 OFDM-based communications, Guard Interval is used to ensure that distinct transmissions occur between the successive data symbols transmitted by a device. The standard symbol Guard Interval used in 802.11 OFDM is 800 nanoseconds in duration. To increase data rates, the 802.11 standard added optional support for a 400 nanoseconds guard interval (Short Guard Interval). This would provide approximately an 11% increase in data rates. However, using the Short Guard Interval will result in higher packet error rates when the delay spread of the RF channel exceeds the Short Guard Interval, or if timing synchronization between the transmitter and receiver is not precise. By Default, Short Guard Interval is enabled on the wireless radio.</p> <p>If the multipath effect is too serious (too many metals or other reflecting materials), disabling Short Guard Interval is recommended.</p>
<b>High Efficiency</b>	Enable/Disable 802.11ax high efficiency wireless functionality. When disabled, the HE mode capable AP will downgrade to VHT (Very High Throughput) mode.

## 6 Maintenance and service

- When designing this device, Hirschmann largely avoided using high-wear parts. The parts subject to wear and tear are dimensioned to last longer than the lifetime of the product when it is operated normally. Operate this device according to the specifications.
- Hirschmann is continually working on improving and developing their software. Check regularly whether there is an updated version of the software that provides you with additional benefits. You find information and software downloads on the Hirschmann IT product pages on the Internet (<https://catalog.belden.com/>)
- Depending on the degree of pollution in the operating environment, check at regular intervals that ports in the device are not obstructed.

**Note:** You find information on settling complaints on the Internet at:

<http://www.beldensolutions.com/en/Service/Repairs/index.phtml>.

## 7 Disassembly

- Disconnect the data cables.
- Disable the supply voltage.
- Remove the antennas.
- Disconnect the grounding.

# 8 Technical data

## 8.1 General technical data

Dimensions W x H x D	DAP645/ DAP646/ DAP647	See "Dimension drawings" on page 42
Weight	DAP645/ DAP646 DAP647	2.5kg (88.18lb) 2.7kg (95.24lb)
Supply voltage	Connection type	PoE Input
	Rated voltage	PoE Input: 54 V
	Rated current	PoE Input: 600mA/1600mA
	maximum tolerances	PoE Input: 42.5~57 V
	Overload current protection on the device	Non-replaceable fuse
Climatic conditions during operation	Minimum clearance around the device	Top and bottom device side: 30 cm (11.81 in) Left and right device side: 2 cm (0.79 in)
	Ambient air temperature	-40°C ... +65°C (-40°F ... +149°F)
	Humidity	0% to 100% non-condensing
Climatic conditions during storage	Ambient air temperature	-40°C ... +85°C (-40°F ... +185°F)
	Humidity	0% to 100% non-condensing
Pollution degree		2
Wind resistance		Up to 100MPH sustained winds Up to 165MPH sustained gusts
Protection classes	Laser protection	Class 1 in compliance with IEC 60825-1
	Degree of protection	IP67



## 8.2 Dimension drawings

DAP645/DAP646

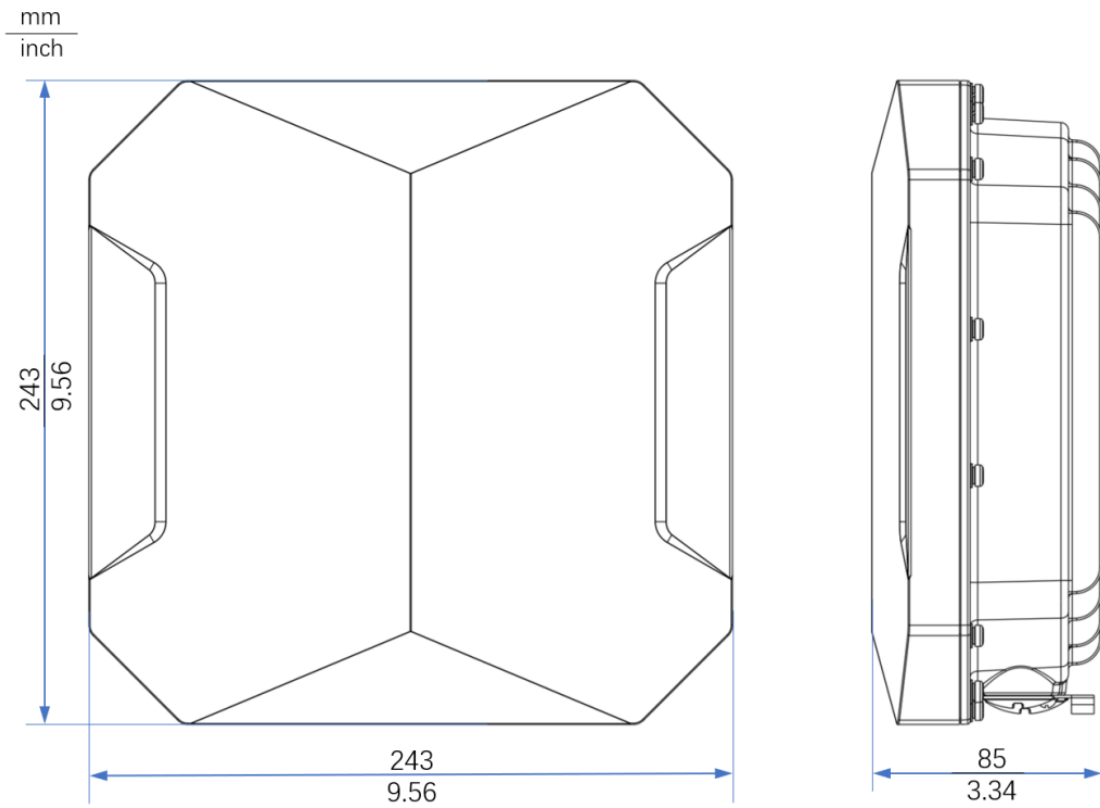

DAP647

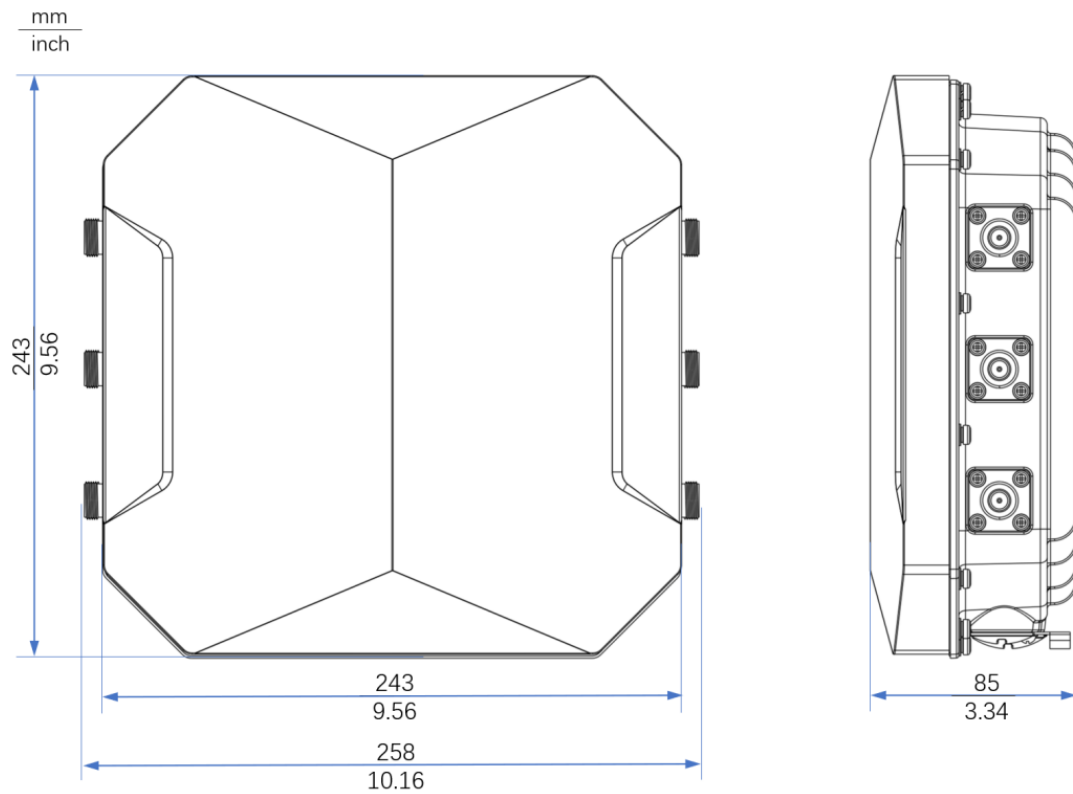

## 8.3 WLAN module specifications

### 8.3.1 Radio technology

Antenna connection	Each WLAN module: 6 x N socket
Range	Depending on the antenna used, frequency range and data rate
Encryption	<ul style="list-style-type: none"><li>▶ Static WEP</li><li>▶ WPA3 Personal</li><li>▶ WPA2 Personal</li><li>▶ WPA Personal</li><li>▶ 802.1x/EAP</li><li>▶ WPA3 Enterprise</li><li>▶ WPA2 Enterprise</li></ul>
Frequency range	<ul style="list-style-type: none"><li>▶ Support of 2.4 GHz: 2400 MHz to 2483.5 MHz</li><li>▶ Support of 5 GHz: 5150 MHz to 5250 MHz 、 5250 MHz to 5350 MHz、 5470 MHz to 5725 MHz、 5725 MHz to 5850 MHz</li></ul>
Modulation technology	<ul style="list-style-type: none"><li>▶ 802.11b: BPSK, QPSK, CCK</li><li>▶ 802.11a/g/n/ac: BPSK, QPSK, 16-QAM, 64-QAM, 256-QAM</li><li>▶ 802.11ax: BPSK, QPSK, CCK, 16-QAM, 64-QAM, 256-QAM, 1024-QAM</li></ul>
Radio topology	▶ WLAN Access-Point, MESH, Bridge

### 8.3.2 Roaming

- ▶ IEEE 802.11k(Radio Resource Measurement)
- ▶ IEEE 802.11v(Wireless Network Management)
- ▶ IEEE 802.11r(Fast Roaming)
- ▶ OKC (Opportunistic Key Caching)
- ▶ PMK Caching

### 8.3.3 Receiving sensitivity, transmit power, and data rate of the WLAN module

The values shown in the following tables are the maximum values of the WLAN module. The values are in no case to be perceived as a guaranteed property of the overall product. For some country profiles, the module reduces data rate and transmit power automatically. The reason for are national standards.

RF performance table				
Rate	Receive sensitivity (per chain)		Maximum transmit power (per chain)*	
	2.4 GHz	5 GHz	2.4 GHz	5 GHz
1 Mb/s	-99		22 dBm	
11 Mb/s	-89		22 dBm	
6 Mb/s	-93	-91	22 dBm	21 dBm
54 Mb/s	-76	-74	21 dBm	20 dBm
HT20 (MCS0/8)	-92	-90	22 dBm	21 dBm
HT20 (MCS7/15)	-74	-72	21 dBm	19 dBm
HT40 (MCS0/8)	-91	-88	22 dBm	21 dBm
HT40 (MCS7/15)	-74	-70	21 dBm	18 dBm
VHT20 (MCS0)	-92	-90	22 dBm	21 dBm
VHT20 (MCS8)	-70	-68	20 dBm	18 dBm
VHT40 (MCS0)	-91	-88	22 dBm	21 dBm
VHT40 (MCS9)	-68	-64	20 dBm	18 dBm
VHT80 (MCS0)		-86		21 dBm
VHT80 (MCS9)		-61		18 dBm
HE20 (MCS0)	-94	-92	22 dBm	21 dBm
HE20 (MCS11)	-63	-62	20 dBm	17 dBm
HE40 (MCS0)	-91	-89	22 dBm	21 dBm
HE40 (MCS11)	-62	-60	20 dBm	17 dBm
HE80 (MCS0)		-87		21 dBm
HE80 (MCS11)		-58		17 dBm

## 8.4 EMC

EMC interference immunity			
EN 61000-4-2	Electrostatic discharge		
EN 60601-1-2	Contact discharge, test level 4		8 KV
EN 61131-2	Air discharge, test level 4		15 KV
EN 61000-4-3	Electromagnetic field		
EN 60601-1-2	80 MHz ... 3000 MHz		max. 10 V/m
EN 60601-1-2	3000 MHz ... 6000 MHz		3 V/m
EN 61000-4-4	Fast transients (burst), test level 4		
EN 60601-1-2	Power line		4 KV
EN 60601-1-2	Data line		1 KV
EN 61000-4-5	Voltage surges		
EN 60601-1-2	Power line	line/line	1 KV
EN 60601-1-2	Power line	line/ground	2 KV
	Data line	line/ground	6 KV
EN 61000-4-6	Conducted interference voltages, test level		
EN 60601-1-2	3		
EN 60601-1-2	150 kHz ... 80 MHz		10 V
EMC interference emission			
EN 55032	Class A		
FCC 47 CFR Part 15	Class A		

## 8.5 Mechanical

Immunity	
Vibration	IEC 60068-2-6 Test FC test level according to IEC 61131-2 IEC 60068-2-64 test level in accordance with IEC 61131-2
Shock	IEC 60068-2-27 Test Ea test level in accordance with IEC 61131-2

## 8.6 Network range

### 10/100/1000/2500 Mbit/s twisted pair port

Length of a twisted pair segment max. 100 m (328 ft) (for Cat5e cable)

Network range: 10/100/1000/2500 Mbit/s twisted pair port

Product code MTS-SFP-1G-...	Mode <sup>a</sup>	Length of Wave	F/O cable length example <sup>b</sup>	Optical attenuation	BLPc/dispersion
-TX/RJ45...	TX/RJ 45	Full Duplex Negotiation	100 m	-	-
-SX/LC...	MM	850 nm	550 m (> 8 dB link budget at 850nm)	3.0 dB/km	-
-LX/LC...	SM	1310 nm	20 km (> 15 dB link budget at 1310nm)	0.32 dB/km	-
-LX+/LC...	SM	1310 nm	40 km (> 22 dB link budget at 1310nm)	0.32 dB/km	-
-LH/LC...	SM	1550 nm	80 km (> 22 dB link budget at 1550nm)	0.18 dB/km	18 ps/(nmxkm)
-LH+/LC	SM	1550 nm	120 km (> 32 dB link budget at 1550nm)	0.18 dB/km	18 ps/(nmxkm)
-BIDI-TypeA- LX/LC...	SM	TX1310 nm RX1550 nm	10 km (>14 dB link budget at 1310/1550 nm)	0.18 dB/km	18 ps/(nmxkm)
-BIDI-TypeB- LX/LC...	SM	TX1550 nm RX1310 nm	10 km (<14 dB link budget at 1550/1310 nm)	0.32 dB/km	-
-LX+/LC-1550...	SM	1550 nm	40 km (> 19 dB link budget at 1550nm)	0.18 dB/km	-

Fiber port 1G SFP module

a. MM =multi-module, SM =simple module, LH =single mode long haul

b. When optical fiber data is observed, it includes 3dB system reserve

## 8.7 Power consumption/power output

Name	Maximum power consumption	Power output
DAP645/646/647	24W (802.3at PoE in) with disabled Eth1 PSE	81.86 Btu (IT)/h
	46W (802.3bt Type3 PoE in) with Eth1 802.3af PSE enabled	156.91 Btu (IT)/h
	64W (802.3bt Type4 PoE in) with Eth1 802.3at PSE enabled	218.34 Btu (IT)/h

## 9 Scope of delivery

Number	Article
1 x	Device
1 x	Safety instruction
1 x	Qualification
2 x	Cable gland

## 10 Order number

Device	Order number
DAP645-RW	942 999-308
DAP646-RW	942 999-312
DAP647-RW	942 999-316

## 11 Accessories

Designation	Order number
AP-MNT-OUT <i>Outdoor AP mounting kit, Pole/Wall installation, independent packing. Applicable for DAP646/647</i>	942999338
AP-MNT-OUT-H <i>Outdoor AP Down-tilt mount kit, independent package. Applicable for DAP645</i>	942999339
AP-OUT-SFP-KIT <i>Outdoor Fiber Gland, M25 external thread, Support 4.5-8.6mm diameter optical cable, IP67. Applicable for DAP645/646/647 Series</i>	942999343
MTS-SFP-1G-SX/LC <i>1Gbps, Multi-mode, 850nm, LC,550m, DDMI</i>	942999855
MTS-SFP-1G-LX/LC <i>1Gbps, Single-mode,1310nm, LC,20Km, DDMI</i>	942999856
MTS-SFP-1G-LX+/LC <i>1Gbps, Single-mode, 1310nm, LC,40Km, DDMI</i>	942999857
MTS-SFP-1G-BIDI-TypeA-LX/LC <i>1Gbps, Single-mode, TX1310nm, RX1550nm, LC, 10Km-TYPE A</i>	942999860
MTS-SFP-1G-BIDI-TypeB-LX/LC <i>1Gbps, Single-mode, TX1550nm, RX1310nm, LC, 10Km-TYPE B</i>	942999861
MTS-SFP-1G-LX+/LC-1550 <i>1Gbps, Single-mode, 1550nm, LC, 40Km, DDMI</i>	942999862

**Note:** Products recommended as accessories may have characteristics that do not fully correspond to those of the corresponding product. This may limit their possible usage in the overall system.

## 12 Underlying technical standards

Name	
CAN/CSA 22.2 No. 62368-1	Information Technology Equipment – Safety – Part 1: General Requirements
EN 300 328	Electromagnetic compatibility and radio spectrum matters (ERM) - bandwidth transfer systems - data transmission equipment operating in 2.4 GHz ISM band and using spread spectrum modulation technology
EN 301 893	Broadband radio access networks (BRAN) – 5 GHz high performance Remote Local Area Network (RLAN)
EN 301 489-1	Electromagnetic compatibility for radio equipment and services
EN 301 489-17	Electromagnetic compatibility (EMC) for radio equipment and services - specific conditions for 2.4 GHz broadband transmission systems and 5 GHz high-performance RLAN equipment
UL 62368-1	Audio/video, information and communication technology equipment - Part 1: Safety requirements
EN 55032	Electromagnetic compatibility of multimedia equipment –Emission Requirements
IEC/EN 62368-1	Equipment for audio/video, information and communication technology - Part 1: safety requirements
EN 60950-22	Installations of IT equipment – Security – Part 22: Outdoor Equipments
EN55035	Electromagnetic compatibility of multimedia equipment – Immunity requirements
EN 61131-2	Programmable controllers – Part 2: Equipment requirements and tests
FCC 47 CFR Part 15	Code of Federal Regulations
EN 60601-1-1	Medical electrical equipment -Part 1: General requirements for safety – Collateral standard - Safety requirements for medical electrical systems
EN 60601-1-2	Medical electrical equipment -Part 1-2: General requirements for basic safety and essential performance - Collateral Standard: Electromagnetic disturbances - Requirements and tests
Wi-Fi 6	IEEE 802.11ax - IEEE Standard for Information Technology- Telecommunications and Information Exchange between Systems Local and Metropolitan Area Networks--Specific Requirements Part 11: Wireless LAN Medium Access Control (MAC) and Physical Layer (PHY) Specifications Amendment 1: Enhancements for High-Efficiency WLAN

The device has an approval based on a specific standard exclusively if the approval indicator appears on the device casing.

The device generally fulfills the technical standards named in their current versions.

# **A Further support**

## **Technical questions**

For technical questions, please contact any Hirschmann IT dealer in your area or Hirschmann IT directly

You find the addresses of our partners on the Internet at <https://catalog.belden.com/>

A list of local telephone numbers and email addresses for technical support directly from Hirschmann IT is available at <https://catalog.belden.com/>

This site also includes a free of charge knowledge base and a software download section.



# HIRSCHMANN IT

---

A **BELDEN** BRAND