

## User Manual

## Installation

### Dragonfly Enterprise Wireless Access Point

DAP620

DAP640

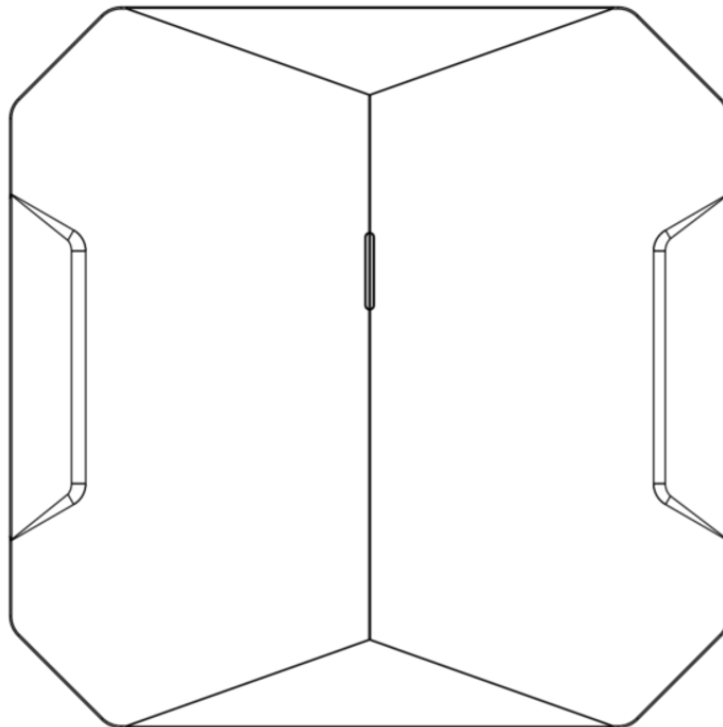

Even if not specifically stated, the copyrighted trademark names in this manual shall not be deemed free of charge in the sense of the trademark and trade name protection act and thus freely available to anyone.

© 2022 Belden Singapore Pte Ltd

Both the manual and software are protected by copyright. All rights reserved. All or any part of this manual shall be prohibited from being reproduced, copied, translated or converted into any electronic media or machine-scannable form, except in the case that you make a copy of the software for your own use.

The performance characteristics described herein shall be binding only upon the express consent of the parties at the time of signing the contract. This paper is produced by Belden within its capacity. Belden reserves the right to change the contents of this manual without prior notice. Belden does not guarantee the correctness or accuracy of the information in this manual.

Belden shall not be liable for damages caused by the use of network components or related operating software. And the conditions of use specified in the license contract are referred to in this manual.

You may access the latest version of this manual at the product website of Hirschmann IT:  
<https://catalog.belden.com>

## Contents

<b>Important information</b>	<b>5</b>
<b>Safety instructions</b>	<b>6</b>
Notes for countries with the following country codes:	10
Supplier's Declaration of Conformity	12
U.S. Contact Information	12
<b>About this manual</b>	<b>14</b>
<b>Key</b>	<b>14</b>
<b>1 Description</b>	<b>15</b>
1.1 General device description	15
1.2 Device name and product code	15
1.3 Device view DAP620	16
1.4 Device view DAP640	18
1.5 Power supply	20
1.6 Ethernet ports	21
1.7 Display elements	22
1.8 Management interfaces	23
<b>2 Installation</b>	<b>25</b>
2.1 Checking the package contents	26
2.2 Installing the device	26
2.3 Connecting the power supply	32
2.4 Connecting data cables	34
<b>3 First login (Password change)</b>	<b>35</b>
<b>4 Defining WLAN basic settings</b>	<b>37</b>
<b>5 Configuring the transmit power</b>	<b>38</b>
<b>6 Maintenance and service</b>	<b>40</b>
<b>7 Disassembly</b>	<b>41</b>

<b>8</b>	<b>Technical data .....</b>	<b>42</b>
8.1	General technical data .....	42
8.2	Dimension drawings.....	44
8.3	WLAN module specifications .....	45
8.4	EMC.....	47
8.5	Mechanical.....	47
8.6	Network range.....	48
8.7	Power consumption/power output .....	48
<b>9</b>	<b>Scope of delivery .....</b>	<b>49</b>
<b>10</b>	<b>Order number .....</b>	<b>49</b>
<b>11</b>	<b>Underlying technical standards .....</b>	<b>50</b>
<b>A</b>	<b>Further support.....</b>	<b>51</b>

# Important information

**Note:** Read these instructions carefully and familiarize yourself with the device before trying to install, operate, or maintain it. The following notes may appear throughout this documentation or on the device. These notes warn of potential hazards or call attention to information that clarifies or simplifies a procedure.

## Symbol explanation



This is a general warning symbol. This symbol alerts you to potential personal injury hazards. Observe all safety notes that follow this symbol to avoid possible injury or death.



If this symbol is displayed in addition to a safety instruction of the type “Danger” or “Warning”, it means that there is a danger of electric shock and failure to observe the instructions will inevitably result in injury.



This symbol indicates the danger of hot surfaces on the device. In connection with safety instructions, non-observance of the instructions will inevitably result in injuries.



## DANGER

**DANGER** draws attention to an immediately dangerous situation, which will **inevitably** result in a serious or fatal accident if not observed.



## WARNING

**WARNING** indicates a potentially hazardous situation which, if not avoided, **could** result in death or serious injury.



## CAUTION

**CAUTION** indicates a possible danger which, if not avoided, may result in minor injuries.

## NOTICE

**NOTE** provides information about procedures that do not involve the risk of injury.

# Safety instructions



## UNCONTROLLED MACHINE ACTIONS

To avoid uncontrolled machine actions caused by data loss, configure all data transmission devices individually.

Before you start any machine, which is controlled via data transmission, ensure to complete the configuration of all data transmission devices.

**Failure to follow this instruction can result in death, serious injury, or equipment damage.**

## ▮ General safety instructions

You operate this device with electricity. Improper usage of the device entails the risk of physical injury or significant property damage. The proper and safe operation of this device depends on proper handling during transportation, proper storage and installation, and careful operation and maintenance procedures.

- Before connecting any cable, read this document, and the safety instructions and warnings.
- Operate the device with undamaged components exclusively.
- The device is free of any service components. In case of a damaged or malfunctioning device, turn off the supply voltage and return the device to Hirschmann for inspection.

## ▮ Certified usage

- Use the product only for the application cases described in the Hirschmann IT product information, including this manual.
- Operate the product only according to the technical specifications. [See “Technical data” on page 40.](#)
- Connect to the product only components suitable for the requirements of the specific application case.

## ▮ Installation site requirements

“Equipment is intended for installation in Restricted Access Area”

Restricted access location:

- ▶ The location is outside the operator access area.
  - ▶ The location is accessible to the service personnel even when the device is switched on.
- During the installation, make sure that you adhere to the regulations of the country in which you are operating the device.

## ▮ **Indoor installation**

Applies to device with supply voltage (48 V DC and POE):

- ▶ You connect the device to a power supply that complies with the requirements for a safety extra-low voltage (SELV) according to IEC/EN 62368-1.
- ▶ In case of supply via Power over Ethernet (PoE), the PoE data cable and the data cables are laid exclusively inside the building.

## ▮ **Device casing**

Only technicians authorized by the manufacturer are permitted to open the casing.

- Never insert pointed objects (narrow screwdrivers, wires, etc.) into the device or into the connection terminals for electric conductors. Do not touch the connection terminals.

## ▮ **Equipment usage**

Only instructed or skilled person allowed to use the equipment (No ordinary person allowed).

## ▮ **Qualification requirements for personnel**

- Only allow qualified personnel to work on the device. Qualified personnel have the following characteristics:
  - ▶ Qualified personnel are properly trained. Training as well as practical knowledge and experience make up their qualifications. This is the prerequisite for grounding and labeling circuits, devices, and systems in accordance with current standards in safety technology.
  - ▶ Qualified personnel are aware of the dangers that exist in their work.
  - ▶ Qualified personnel are familiar with appropriate measures against these hazards in order to reduce the risk for themselves and others.
  - ▶ Qualified personnel receive training on a regular basis.

## ▮ **National and international safety regulations**

- Verify that the electrical installation meets local or nationally applicable safety regulations.

## ▮ Requirements for connecting electrical wires

Before connecting the electrical wires, **always** verify that the requirements listed are complied with.

### The following requirements apply without restrictions:

- ▶ The electrical wires are voltage-free.
- ▶ The cables used are permitted for the temperature range of the application case.
- ▶ The voltage connected complies with the requirements for a safety extra-low voltage (SELV) ES1 as per IEC/EN 62368-1

Table 1: Requirements for connecting electrical wires

## ▮ Requirements for connecting the supply voltage

### The following requirements apply without restrictions:

Only for device

powered by 48 V DC

**All** of the following requirements are complied with:

- ▶ The supply voltage corresponds to the voltage specified on the type plate of the device.
- ▶ The power supply conforms to overvoltage category I or II.
- ▶ The power supply has an easily accessible disconnecting device (for example a switch or a plug). This disconnecting device is clearly identified. In the case of an emergency, it is clear which disconnecting device belongs to which power supply cable.
- ▶ The power supply cable is suitable for the voltage, the current and the physical load. Hirschmann recommends a wire diameter of 0.25 mm<sup>2</sup> (AWG24) to 0.75 mm<sup>2</sup> (AWG19).

### The following requirements apply alternatively:

Only for device

powered by 48 V DC

#### The following requirements apply alternatively:

Alternative 1 The power supply complies with the requirements for a limited power source (LPS) PS2 according to IEC/EN 62368-1.

Alternative 2 Relevant for North America:  
The power supply complies with the requirements according to NEC Class 2.

Alternative 3 **All** of the following requirements are complied with:

- ▶ The power supply complies with the requirements for a safety extra-low voltage (SELV) ES1 according to IEC/EN 62368-1.
- ▶ A suitable fuse is located in the plus conductor of the power supply.



## ▮ **CE marking**

The labeled devices comply with the regulations contained in the following European directive(s):

2011/65/EU and 2015/863/EU (RoHS)

Directive of the European Parliament and of the Council on the restriction of the use of certain hazardous substances in electrical and electronic equipment.

2014/53/EU (RED)

Directive of the European Parliament and of the council on the harmonization of the laws of the Member States relating to the making available on the market of radio equipment.

 This product may be operated in all EU (European Union) countries under the condition that it has been configured correctly.

In accordance with the above-named EU directive(s), the EU conformity declaration will be available to the relevant authorities at the following address:

Hirschmann Automation and Control GmbH  
Stuttgarter Str. 45-51  
72654 Neckartenzlingen  
Germany

You find the EU conformity declaration as PDF file for downloading on the Internet at: <https://catalog.belden.com>

The product can be used in residential areas (residential, commercial and light-industrial environments).

**Notes for countries with the following country codes:**

								
AT	BE	BG	CH	CY	CZ	DE	DK	EE
EL	ES	FI	FR	HR	HU	IE	IT	LI
LT	LU	LV	MT	NL	NO	PL	PT	RO
RS	SE	SI	SK	TR				

- ▶ The RED compliance requires compliant operation of the device in the 5 GHz band channels. Compliant operation of the device is achieved by an unchangeable determination of the country setting. To obtain RED compliance, perform the work steps described in chapter [“Obtaining compliance for operation in the European Union and in the United Kingdom \(UK\)”](#) on page 11.

## ▮ **UKCA marking**

The labeled devices comply with the following UK regulations:

- ▶ S.I. 2012 No. 3032 Restriction of the Use of Certain Hazardous Substances in Electrical and Electronical Equipment Regulations
- ▶ S.I. 2017 No. 1206 Radio Equipment Regulations



The UKCA conformity declaration will be available to the relevant authorities at the following address:

Belden UK Ltd.  
1 The Technology Centre, Station Road  
Framlingham, IP13 9EZ, United Kingdom

You find the UKCA conformity declaration as PDF file for downloading on the Internet at: <https://www.doc.hirschmann.com/certificates.html>

## ▮ **LED or laser components**

LED or LASER components according to IEC 60825-1(2014):  
CLASS 1 LED PRODUCT

## ▮ **FCC note**

### **Supplier's Declaration of Conformity 47 CFR § 2.1077 Compliance Information**

DAP620

DAP640

### **U.S. Contact Information**

Belden – St. Louis

1 N. Brentwood Blvd. 15th Floor

St. Louis, Missouri 63105, United States

Phone: 314.854.8000

This product has been tested and found to comply with the limits for a Class B digital device pursuant to Part 15 of the FCC Rules. These limits are designed to provide reasonable protection against harmful interference when the equipment is operated in a commercial environment. This product generates, uses, and can radiate radio frequency energy and, if not installed and used in accordance with the manufacturer's instruction manual, may cause harmful interference with radio communications. Operation of this product in a residential area is likely to cause harmful interference, in which case you will be required to correct the interference at your own expense.

This device complies with Part 15 of the FCC Rules. Operation is subject to the following two conditions:

(1) This device may not cause harmful interference, and (2) this device must accept any interference received, including interference that may cause undesired operation.

**FCC Caution:** Any changes or modifications not expressly approved by the party responsible for compliance could void the user's authority to operate this equipment.

## ▮ **RF exposure warning**

This equipment complies with FCC and CE radiation exposure limits set forth for an uncontrolled environment.

This product may not be collocated or operated in conjunction with any other antenna or transmitter.

This equipment must be installed and operated in accordance with provided instructions and the antenna(s) used for this transmitter must be installed to provide a separation distance of at least 20 cm from all persons and must not be collocated or operating in conjunction with any other antenna or transmitter.

## ▮ **Recycling note**

After usage, this device must be disposed of properly as electronic waste, in accordance with the current disposal regulations of your county, state, and country.

# About this manual

The “Installation” user manual contains a device description, safety instructions, a description of the display, and the other information that you need to install the device.

Documentation mentioned in the “User Manual Installation” that is not supplied with your device as a printout can be found as PDF files for downloading on the Internet at: <https://catalog.belden.com>

## Key

The symbols used in this manual have the following meanings:

▶	Listing
□	Work step
▮	Subheading

# 1 Description

## 1.1 General device description

Hirschmann IT Dragonfly indoor series is next gen enterprise level Wi-Fi6 (802.11ax) access point. The indoor series include DAP620 and DAP640.

There are convenient options for managing the device. Manage your devices via:

- ▶ Web browser
- ▶ SSH
- ▶ Telnet

The device works without a fan.

The device complies with the degrees of protection IP41.

## 1.2 Device name and product code

The device name corresponds to the product code.

Order number	Product code	Description
942999300	DAP620-RW	Indoor 802.11ax 2*2 MIMO AP, data rate 1.77Gbps, build-in omni-antenna. Default shipping with mounting kit.
942999304	DAP640-RW	Indoor 802.11ax 4*4 MIMO AP, data rate 2.97Gbps, build-in omni-antenna. Default shipping with mounting kit.

*Table 1: Device name and product code*

## 1.3 Device view DAP620

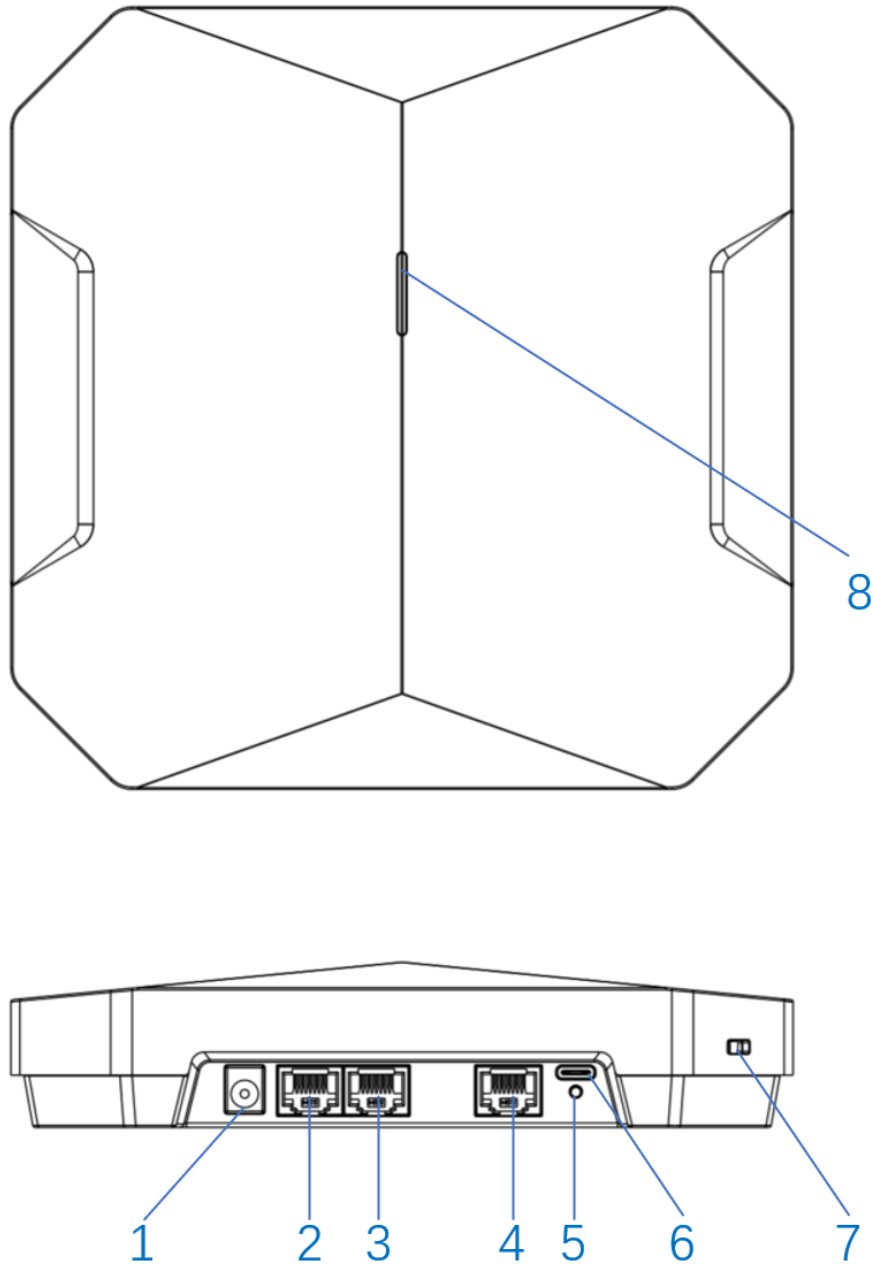

Figure 3: Device view DAP620

1	DC Power Jack	DC 48V power jack, support powering AP through a designated AC-DC power adapter
2	1 Gigabit Eth0	1x 10/100/1000BASE-T autosensing (RJ-45) port, Power over Ethernet (PoE)
3	1 Gigabit Eth1	1x 10/100/1000BASE-T autosensing (RJ-45) port, Power over Ethernet (PoE). In case of only one WAN link, Eth0 would be more preferred
4	Console	The console port is an RJ-45 female connector and can be used to connect to a terminal for direct local management Note: Currently for use by Service &



		Support only
5	Reset	Factory reset. Press reset button for 5s, AP LEDs will quickly flash for 3s, then AP will restart and restore factory configurations
6	USB	USB 2.0 host interface (Type C, output current 0.5A)
7	Security	The AP is equipped with a security lock slot for additional security
8	LED	Hidden LED display that indicates different status with different color

## 1.4 Device view DAP640

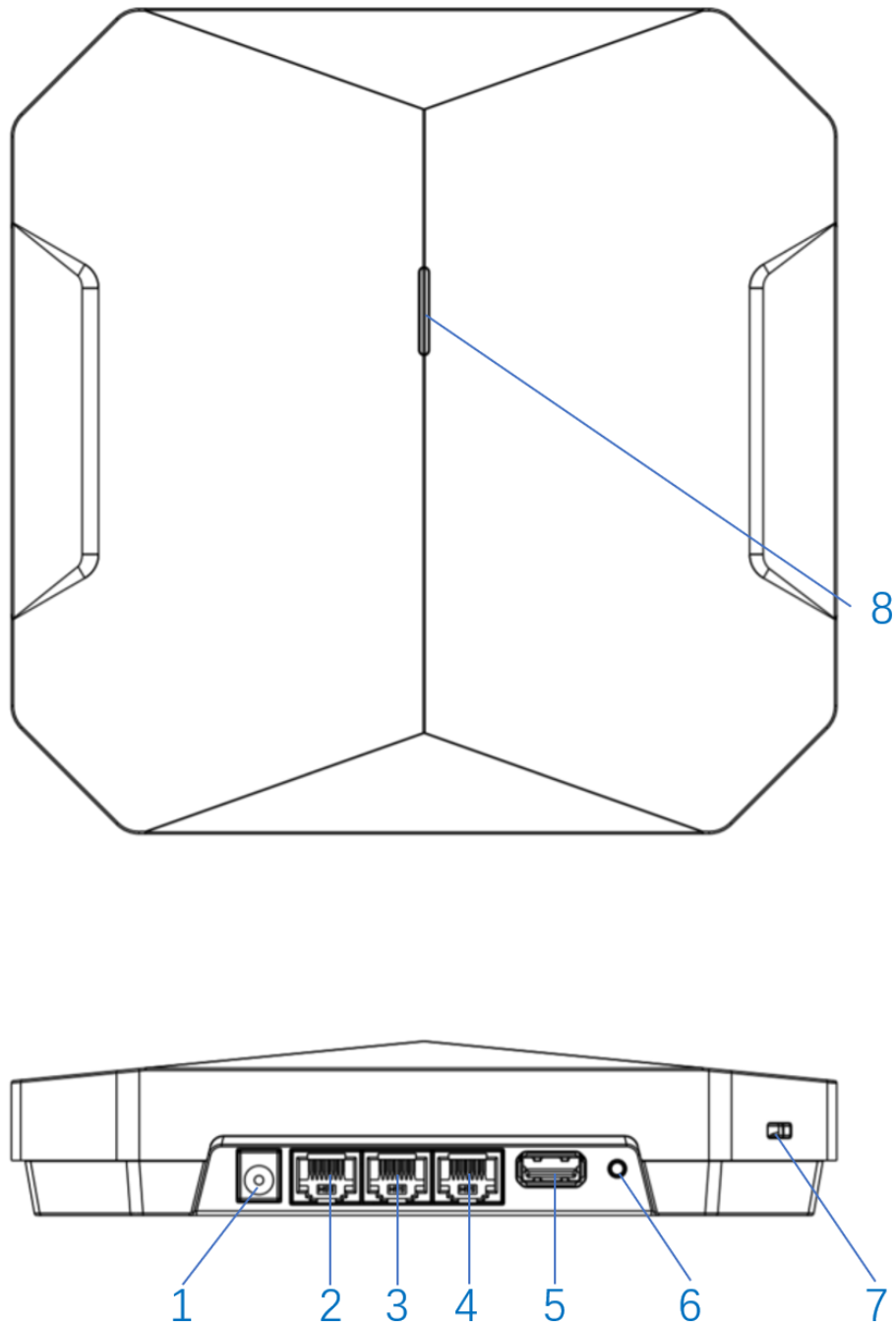

Figure 4: Device view DAP640

1	DC Power Jack	The AP has a single 48V DC power jack socket to support powering through an AC-to-DC power adapter. If PoE is not available, an optional AC-DC adapter kit (sold separately) can be used to power the AP
2	2.5 Gigabit Eth0	1x 100/1000/2.5GBASE-T autosensing (RJ-45) port, Power over Ethernet (PoE)
3	1 Gigabit Eth1	1x 10/100/1000BASE-T autosensing (RJ-45) port, Power over Ethernet (PoE)
4	Console	The console port is an RJ-45 female connector and can be used to connect to a terminal for direct local management. Note: Currently for use by Service & Support

---

		only
5	USB	USB 2.0 host interface (Type A, output current 0.5A)
6	Reset	Factory reset. Press reset button for 5s, AP LEDs will quickly flash for 3s, then AP will restart and restore factory configurations
7	Security	The AP is equipped with a security lock slot for additional security
8	LED	Hidden LED display that indicates different status with different color

---

## 1.5 Power supply

You have the following options to supply your device with voltage:

### 1.5.1 Applies to device with supply voltage (48 V DC and POE)

#### ▮ Power supply via RJ45 socket for PoE port

Your device is a PD (powered device). PSE (power sourcing equipment) connected via a twisted pair cable on the PoE PD port serves as the PoE power supply voltage. The PoE power supply means that no separate power supply is required for your device.

#### ▮ Power supply via AD/DC adaptor

For the power supply of the device, an AD/DC adaptor is available.

#### **For the priority of the power supply, please refer to below description:**

- 1、 Power supply by one network port: any network port connected to PSE alone can normally supply power.
- 2、 Independent DC Power supply: Power supply is normal when the DC port is connected to the Power Adaptor.
- 3、 When two network ports are connected to PSE at the same time:
  - a) The PSE switch is powered on. If the two ports on the AP side are plugged in at the same time (or in sequence), the first port is powered on, and the second port is not. Remove one port. If the port is plugged in first, the device will be powered off and then powered on again. If you remove the port which is inserted later, the power supply is still maintained.
  - b) If PSE switch is in the power off state and both ports on the AP side are inserted, there is a certain probability that the device cannot be powered on after the switch is started (the reason is that the two ports on PSE switch send PD detection signals at the same time, which conflicts with each other; This can be avoided by scripting PSE on the switch.)
- 4、 When the DC port and network port are connected at the same time:
  - a) If the DC is plugged in first and the network port is plugged in later, the DC is powered on. If the network port is not powered on, remove the DC port. The device is powered off and then powered on again.
  - b) When the network port is inserted in first and the DC port is inserted later:
    - i. When the power supply voltage of the network port is higher than that of the DC port: The network port is powered on and the DC port is in hot backup mode. In this case, the device is not powered off no matter the network port or DC is removed first
    - ii. When the voltage of the DC port is higher than that of the network port: The DC port takes over the power supply and the network port does not continue to supply power. If the DC port is removed, the device is powered off and then powered on again

## 1.6 Ethernet ports

You have the option to connect end devices or other segments to the ports of the device via twisted pair cables.

You find information on the pin assignments for making patch cables here:

See [“Pin assignments” on page 21](#).

### 1.6.1 10/100/1000/2500 Mbit/s twisted pair port

This port is a RJ45 socket.

This port supports:

- ▶ Autocrossing (if autonegotiation is activated)
- ▶ Autonegotiation
- ▶ Autopolarity
- ▶ 10 Mbit/s half-duplex mode, 10 Mbit/s full duplex mode
- ▶ 100 Mbit/s half-duplex mode, 100 Mbit/s full duplex mode
- ▶ 1000 Mbit/s full duplex
- ▶ 2500 Mbit/s full duplex

The socket housing is electrically connected with the device housing.

Delivery state: Autonegotiation activated

### 1.6.2 Pin assignments

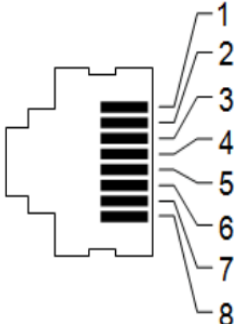
Connector	Pin	Signal Name	PoE
	1	RJ45_DA+	PoE-
	2	RJ45_DA-	PoE-
	3	RJ45_DB+	PoE+
	4	RJ45_DC+	PoE+
	5	RJ45_DC-	PoE+
	6	RJ45_DB-	PoE+
	7	RJ45_DD+	PoE-
	8	RJ45_DD-	PoE-

## 1.7 Display elements

After the supply voltage is set up, the Software starts and initializes the device. Afterwards, the device performs a self-test. During this process, various LEDs light up.

### 1.7.1 Device state

The access point is equipped with LED display that indicates different status with different color.

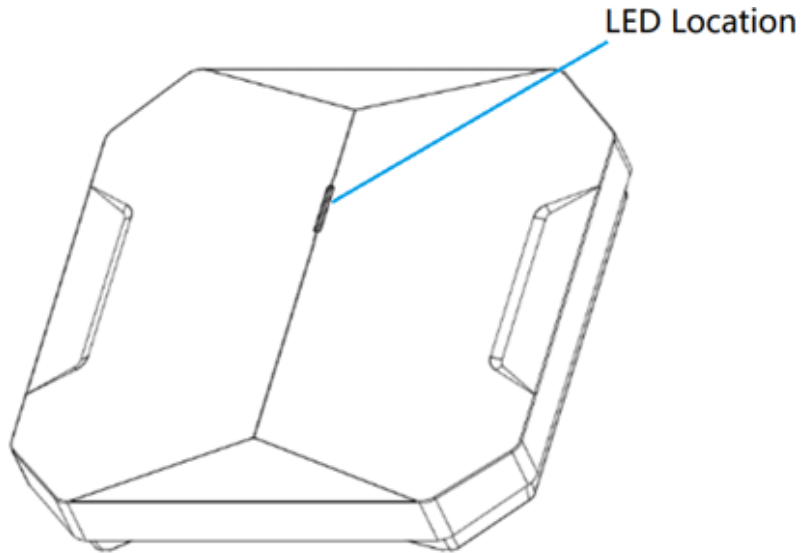

Red	Blue	Green	Status
ON			AP is powered, start up
Flash			Network abnormal (WAN link down)
		Flash	Network normal, without SSID created.
		ON	Network normal, single band working, either 2.4 GHz or 5GHz working.
	ON		Network normal, 2.4GHz and 5GHz dual bands working.
Flash	Flash		OS is upgrading
Flash	Flash	Flash	Used for locating AP.

## 1.8 Management interfaces

### 1.8.1 RS232 interface (external management)

This interface is a RJ45 socket

This interface is serial and enables the local connection of an external management station (VT100 terminal or PC with corresponding terminal emulation). This enables you to set up a connection to the Command Line Interface CLI and to the System Monitor.

Speed	115200 bit/s
Data	8 bit
Stop bit	1 bit
Handshake	Off
Parity	none

The serial console port allows you to connect the AP to a serial terminal or a laptop for direct local management. This port is a RJ-45 female connector with the pinouts.

Connector	Pin	Signal Name	Function
	3	TXD	Transmit
	4	GND	Ground
	5	GND	Ground
	6	RXD	Receive
	Pins not listed must be not connected.		

Table 4: Pin assignment of the RS232 interface (RJ45 socket)

## **1.8.2 Reset button**

The device has a reset button.

Press reset button for 5s, LED will quickly flash for 3s, then the device will restart and restore factory configurations

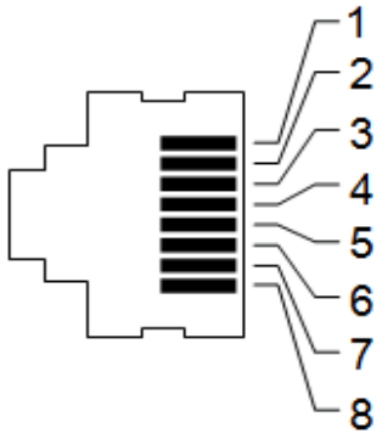

## 2 Installation



### **WARNING**

#### **ELECTRIC SHOCK**

Exclusively install this device in a restricted access location, to which maintenance staff have exclusive access. Install the device in such a way that it is protected against mechanical forces in the area of the power supply.

**Failure to follow this instruction can result in death, serious injury or damage of the equipment.**

These devices are developed for use in commercial environments.  
At the time of delivery, the device is ready for operation.

Applies to device with supply voltage (48 V DC and POE)

To install the device, perform the following work steps:

- ▶ [Checking the package contents](#)
- ▶ [Installing the device](#)
- ▶ [Connecting the power supply](#)
- ▶ [Operating the device](#)
- ▶ [Connecting data cables](#)

## 2.1 Checking the package contents

- According to the device variant, check whether the package contains all items listed in the scope of delivery:  
[“Scope of delivery” on page 47](#)

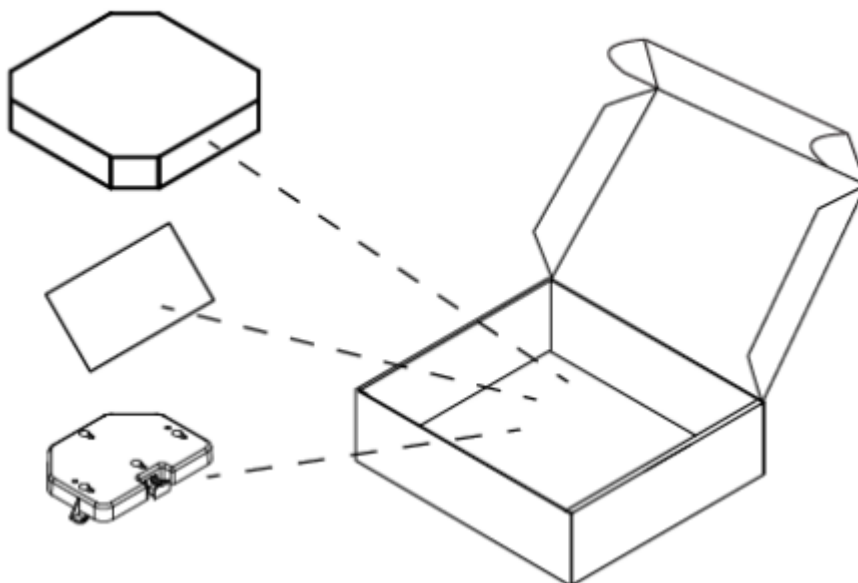

- Check the individual parts for transport damage.

## 2.2 Installing the device

### 2.2.1 Installing the AP bracket on ceiling or wall

You can install the AP on a ceiling or on a wall. You should first determine the location of the installation. The installation position is located at the center of the required coverage area and should be free from obstructions or obvious sources of interference.

- ▶ Minimize the number of obstructions (such as walls) between the AP and user terminals.
- ▶ Electronic equipment or devices (such as microwave ovens) which may produce radio frequency noise should be away from the installation position of the AP.
- ▶ It is strictly prohibited to install around stagnant water, water seepage, leakage or condensation. Avoid cable condensation or water seepage along the cables connecting to the AP.

#### 2.2.1.1 Wall Mount

Perform the following work steps:

- Mark two drilling hole center marks on the wall at a proper location. Make sure they are

of the same height to the ground and have a distance of 100mm between them, equivalent to that between the holes of the AP.

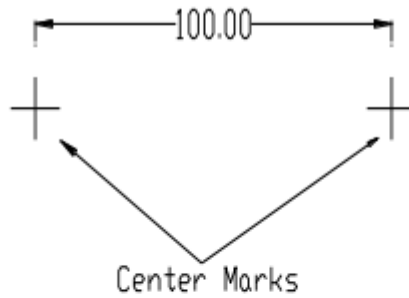

- Drill two holes at the center marks about 6mm in diameter and 25mm in depth. This is approximately the same size as the wall anchors.

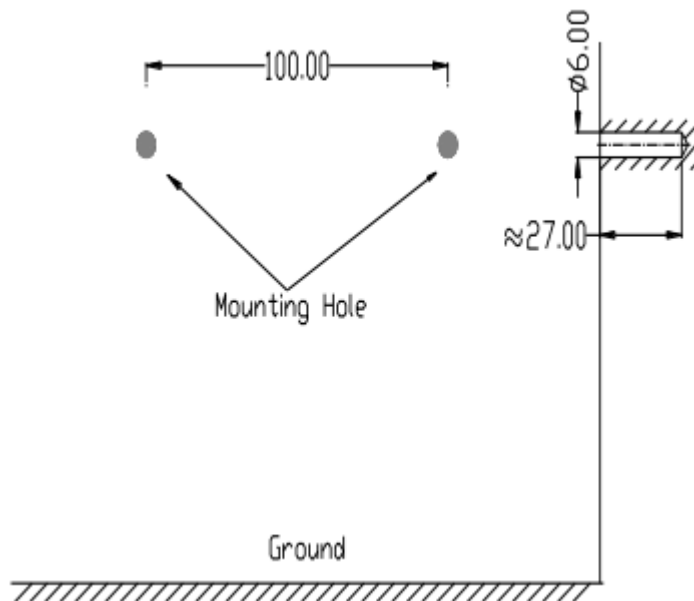

- Insert two wall anchors and tap them into the holes.

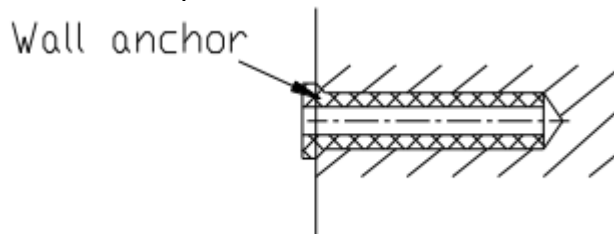

- Insert two screws into the wall anchors with 2mm length left remaining.

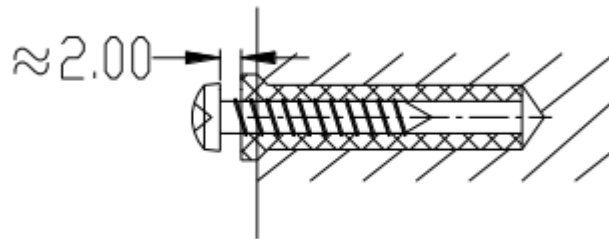

- Push the mounting bracket along the direction of the arrows until it locks in the slot.

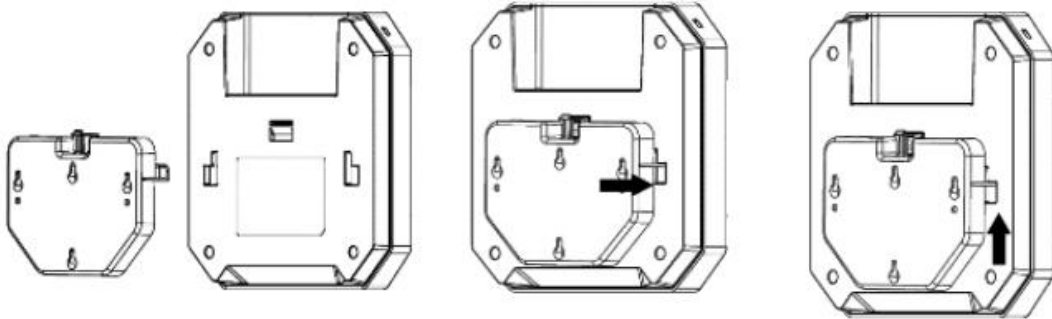

- Connect the cable to the port on the AP.
- Align the bottom holes of mounting bracket with the mounting screws. After inserting push down on the AP until it is secure. The installation is complete.

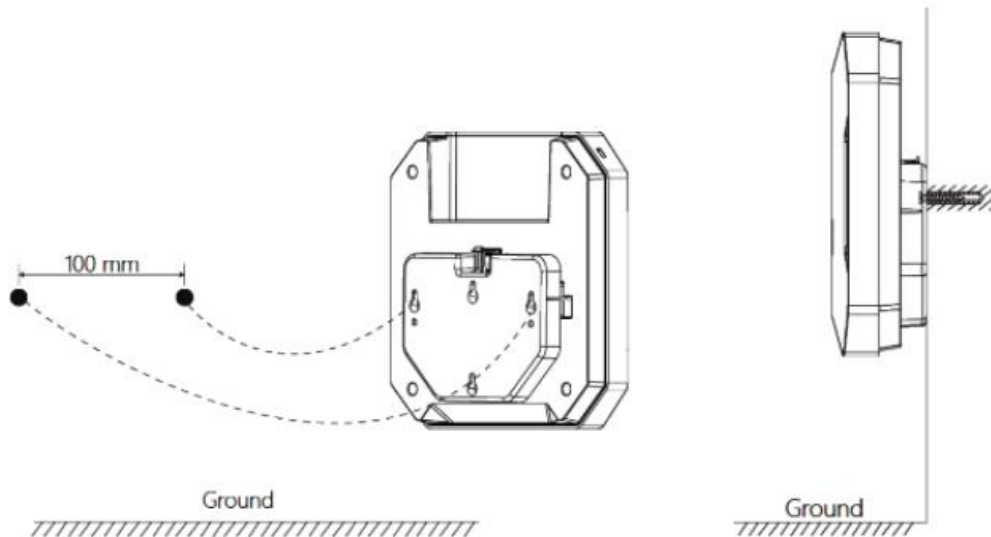

### 2.2.1.2 Ceiling Mount

Ceiling mount support structural ceiling and suspended ceiling.

**Note:**

- *Ceiling mount requires necessary PPE;*
- *To make sure the weight that ceiling material can bear should be greater than 4 times the total weight of the DAP and mounting bracket (Refer to 《EN 300 019 -2 -*

3: Environmental conditions and environmental tests for telecommunications equipment; Part 2-3: Specification of environmental tests; Stationary use at weather protected locations» ) .

### 2.2.1.2.1 Structural ceiling installation steps:

- Mark two drilling hole center marks on the Structural ceiling at a proper location.

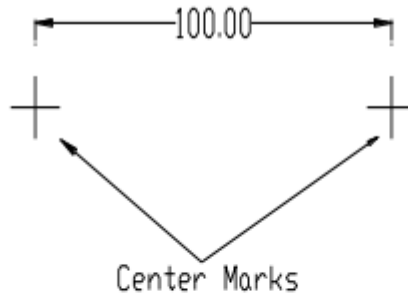

- Drill two holes at the center marks about 6mm in diameter and 25mm in depth. This is approximately the same size as the wall anchors.

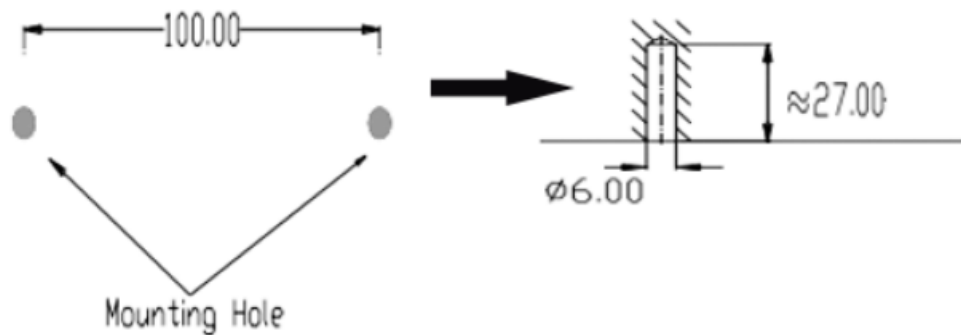

- Align the bottom holes of mounting bracket with the mounting screws, use the two screws to secure the mounting bracket to the ceiling.

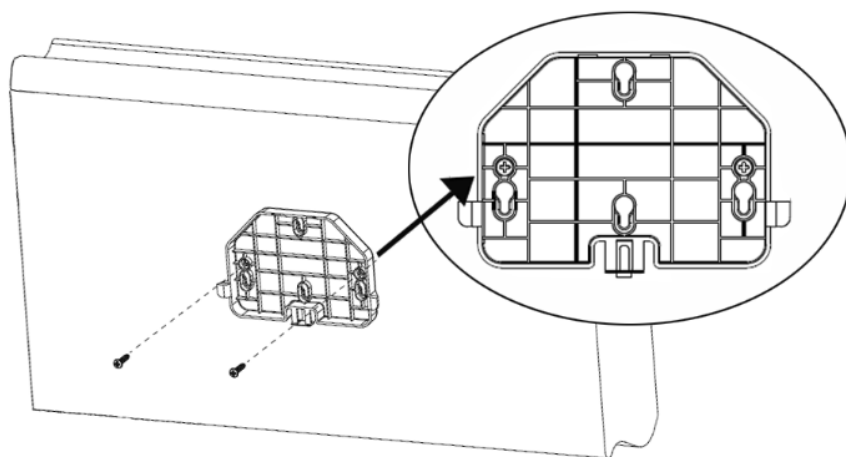

- Connect the cable to the port on the AP.
- Push the AP along the direction of the arrows until it locks in the slot, see Figure below.

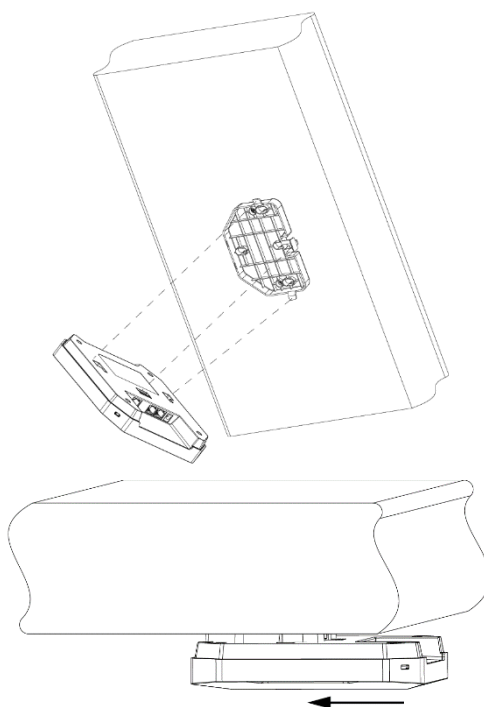

**Note:** Ceiling mount just applicable to DAP620 & DAP640.

#### 2.2.1.2.2 Suspended ceiling installation steps:

- To select installation point, the operator can enter the ceiling to select the best installation point if ceiling is accessible; If not, recommended to select the installation point close to maintenance opening.
- Drill one hole at the installation point, approximately the same size as the network cable.

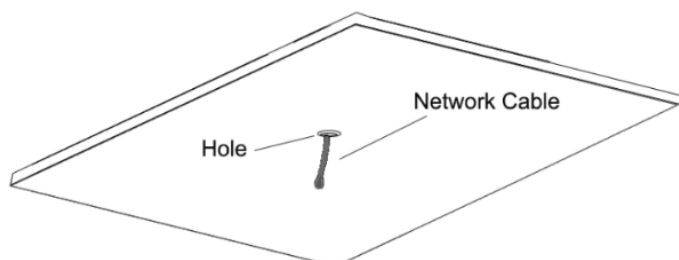

- Mark the position of mounting holes, close to network cable.

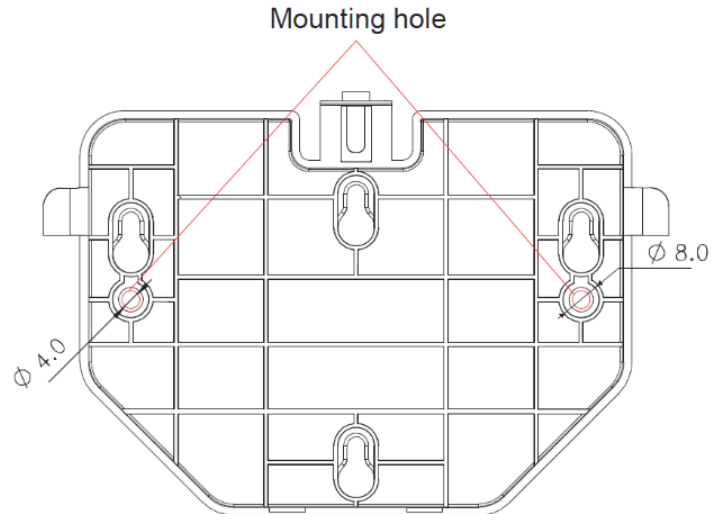

- Drill the holes and follow the anchor instruction to secure the anchor.

**Note:** *The special anchor should be purchased according to the onsite ceiling thickness and installation conditions, and to prepare associated tools.*

- To secure the mounting bracket to the ceiling. See figure below.

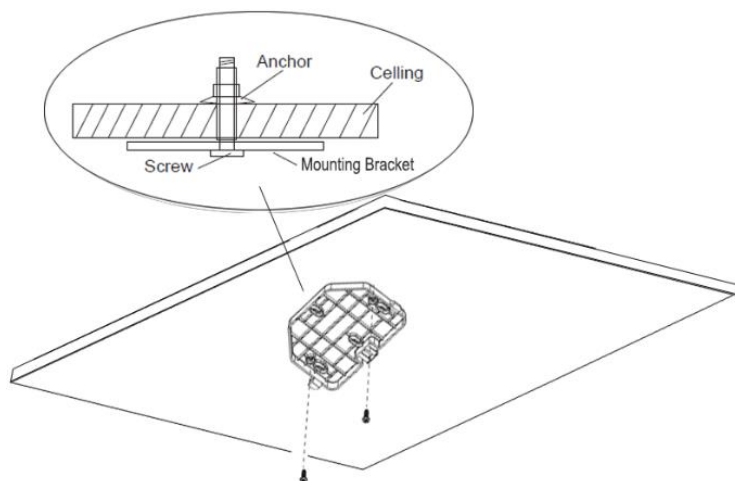

- Push the AP along the direction of the arrows until it locks in the slot.

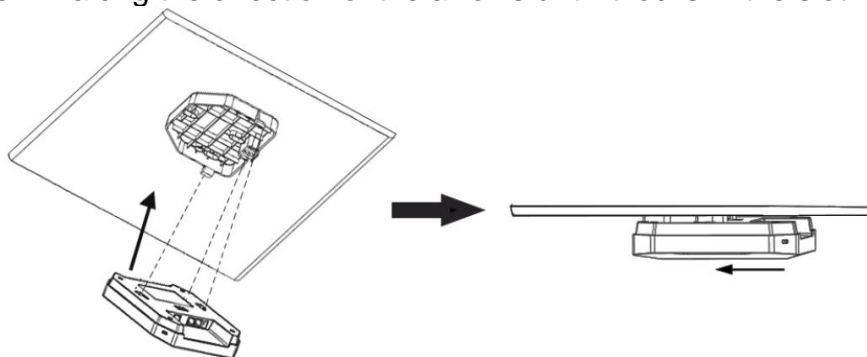

## 2.3 Connecting the power supply

### **WARNING**

#### **ELECTRIC SHOCK**

Before connecting the electrical wires, **always** verify that the requirements listed are complied with.

See “Requirements for connecting electrical wires” on page 8.

See “Requirements for connecting the supply voltage” on page 8.

**Failure to follow this instruction can result in death, serious injury, or equipment damage.**

### **2.3.1 Supply voltage with 48V DC**

The device is powered with AC/DC adaptor, The requirements for connectors as below.

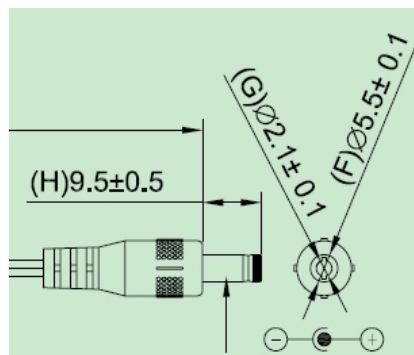

### **2.3.2 Supply voltage with PoE**

### **NOTICE**

#### **MATERIAL DAMAGE**

In a PoE installation, use only devices that comply with the IEEE 802.3af/at standard.

**Failure to follow this instruction can lead to equipment damage.**

You start up the device by connecting the power supply via RJ45 socket for PoE port



- Only connect the device to a PoE network indoors.
- Only run data links indoors (IEEE 802.3 area A).

## 2.4 Connecting data cables

Note the following general recommendations for data cable connections in environments with high electrical interference levels:

- Keep the length of the data cables as short as possible.
- When using copper cables, provide a sufficient separation between power supply cables and the data cables. Ideally, install the cables in separate cable channels.
- Verify that power supply cables and data cables do not run parallel over longer distances. To reduce inductive coupling, verify that the power supply cables and data cables cross at a 90° angle.
- Use shielded data cables for gigabit transmission via copper cables, for example SF/UTP cables according to ISO/IEC 11801.
- Connect the data cables according to your requirements. [See “Ethernet ports” on page 21.](#)
- You find the prescribed tightening torque of the locking screw in chapter: [“General technical data” on page 40.](#)

### 3 First login (Password change)

To help prevent undesired access to the device, it is imperative that you change the default password during initial setup.

Perform the following steps:

- By default, DAP will broadcast the WLAN 'mywifi-xxxx' (xxxx = the last two bytes of the AP MAC address). You can connect to 'mywifi-xxxx' and browse <http://find.dragonflyap.com:8080> to access the AP web page.

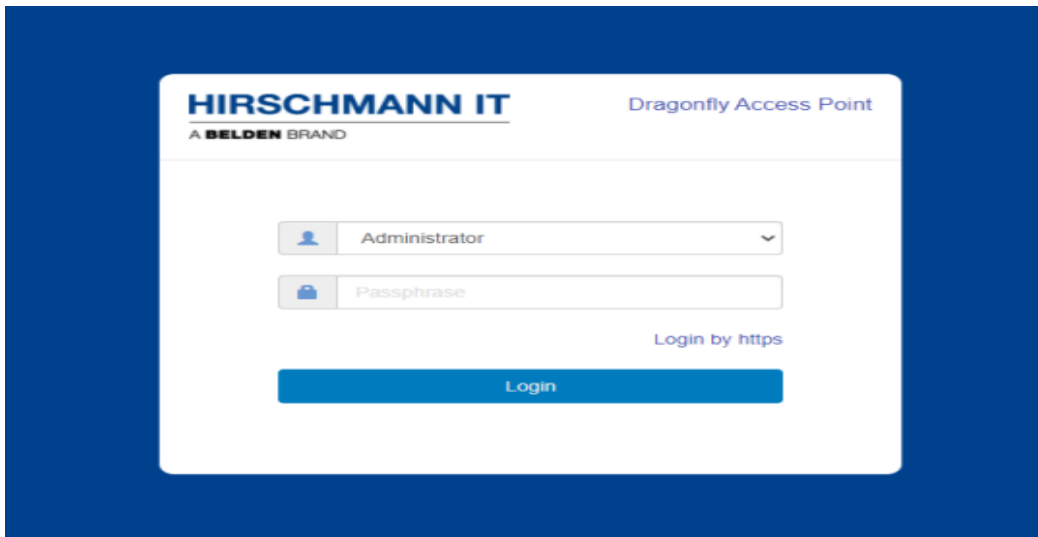

**Note:** Recommend to access AP web Page by Chrome Browser for best user experience.

- Choose Administrator and default password is admin. Login AP web page, and you can access with below figure. Select "Cluster" to cluster mode, or you can select "DAC" to DAC mode.

#### Setup Wizard

Please select management mode of the AP:

Cluster  DAC

Next

**Note:** There are three pre-configured login accounts: Administrator, Viewer and Guest Manager. You may modify the account password, but the account name isn't modifiable. Administrator can configure and check the AP status, Viewer can check the AP status ONLY, while Guest Operator can check the AP status and register accounts for portal authentication. By default, the password for all accounts is 'admin' and the wizard will guide you to modify the Administrator password upon AP login. More detailed configuration guide, please refer to DAP User Manual.

- When initially logging into an AP, a configuration wizard will pop up. The following steps show how to use the setup wizard to modify the Administrator password and create a WLAN.

## Setup Wizard

Welcome to the AP Cluster Web Manager

---The AP Cluster Management System

Back

Next

- Confirm your new password.

## Setup Wizard

Step 1/3 Change your administrator password

Password:

Confirm:

Back

Next

**Note:** *The page below will be displayed to select the country or region*

## Setup Wizard

Step 2/3 Choose your Country or Region

Country/Region:

Albania - AL

Time Zone:

(UTC-12:00)International-Date-Line-West

Back

Next

## 4 Defining WLAN basic settings

You have the following options to define the WLAN basic settings:

- ▶ via the wired local network (LAN)
- ▶ via the wireless network (WLAN), if the WLAN encryption (for example WPA2) is set accordingly in a device with a wireless interface and in the configuration computer.
- ▶ via the RS232 interface

For More details, please refer to user manual.

# 5 Configuring the transmit power

You can modify the transmission power and working channel for the DAP in the RF Configuration Window, shown below, by default, the working channel and transmitting power are automatically managed by Dynamic Radio Management (DRM) technology. If you want to set the channel and power values for an AP manually, you need to disable the Automatic Channel Selection (ACS) and Automatic Power Control (APC); in manual mode the AP transmits power can be adjusted in 1 dB increments

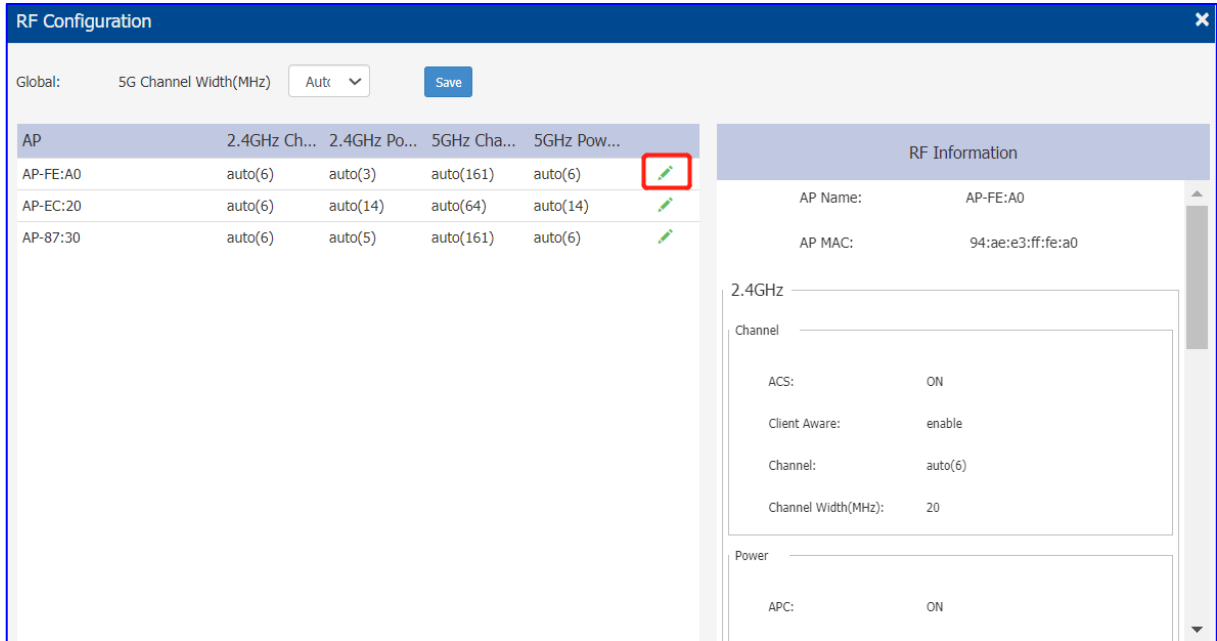

You can specify the channels list/power range applicable for auto selection, which can reduce the risk of low power transmitting or DFS channel conflict, as shown below.

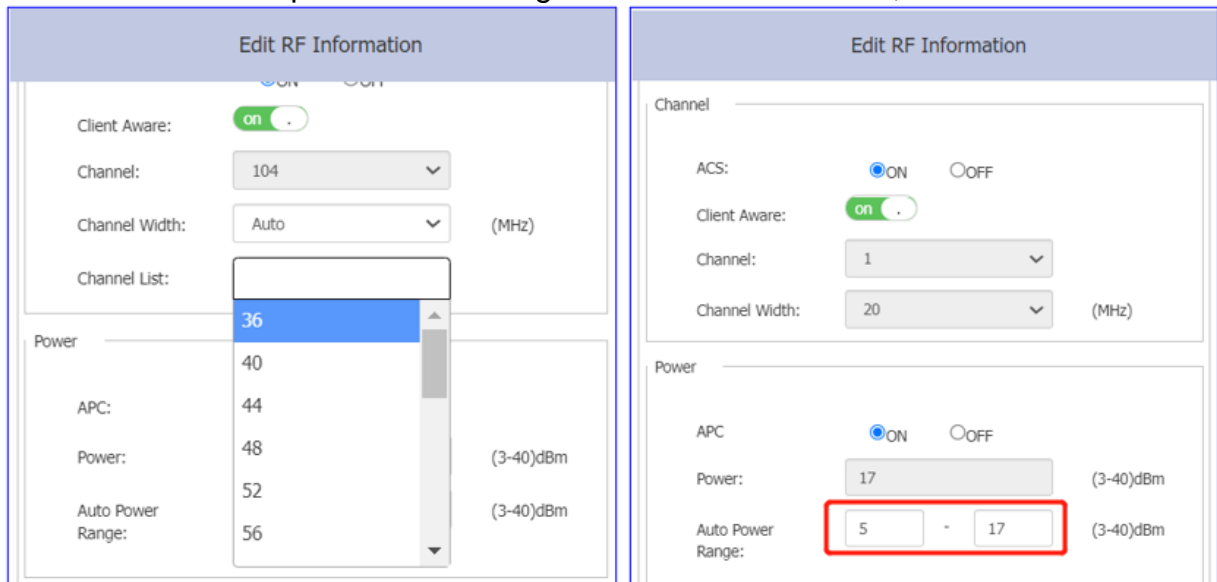

**Note:** DFS relies on the background scanning feature. To ensure the DFS is effective, make sure the background scanning is ON.

Key word specification in RF Configuration Window

Parameter	Specification
<b>Client Aware</b>	When enabled, Auto Channel Selection does not change channels for DAPs with connected clients, except for high-priority events such as RADAR detected. If "Client Aware" is Disabled, the DAP may change to a more optimal channel, which may temporarily disrupt current client traffic.
<b>Short GI</b>	<p>Enable/Disable Short Guard Interval. In IEEE 802.11 OFDM-based communications, Guard Interval is used to ensure that distinct transmissions occur between the successive data symbols transmitted by a device. The standard symbol Guard Interval used in 802.11 OFDM is 800 nanoseconds in duration. To increase data rates, the 802.11 standard added optional support for a 400 nanoseconds guard interval (Short Guard Interval). This would provide approximately an 11% increase in data rates. However, using the Short Guard Interval will result in higher packet error rates when the delay spread of the RF channel exceeds the Short Guard Interval, or if timing synchronization between the transmitter and receiver is not precise. By Default, Short Guard Interval is enabled on the wireless radio.</p> <p>If the multipath effect is too serious (too many metals or other reflecting materials), disabling Short Guard Interval is recommended.</p>
<b>High Efficiency</b>	Enable/Disable 802.11ax high efficiency wireless functionality. When disabled, the HE mode capable AP will downgrade to VHT (Very High Throughput) mode.

## 6 Maintenance and service

- When designing this device, Hirschmann largely avoided using high-wear parts. The parts subject to wear and tear are dimensioned to last longer than the lifetime of the product when it is operated normally. Operate this device according to the specifications.
- Hirschmann is continually working on improving and developing their software. Check regularly whether there is an updated version of the software that provides you with additional benefits. You find information and software downloads on the Hirschmann IT product pages on the Internet (<https://catalog.belden.com/>)
- Depending on the degree of pollution in the operating environment, check at regular intervals that ports in the device are not obstructed.

**Note:** You find information on settling complaints on the Internet at:  
<http://www.beldensolutions.com/en/Service/Repairs/index.phtml>.



## 7 Disassembly

- Disconnect the data cables.
- Disable the supply voltage.
- Disconnect the power supply cable.

# 8 Technical data

## 8.1 General technical data

Dimensions W x H x D	DAP620	See "Dimension drawings" on page 42
Weight	0.574 kg (1.265 lb)	
Supply voltage	Connection type	AC/DC adapter PoE Input
	Rated voltage	AC/DC adapter: 48 V DC PoE Input: 48 V
	Rated current	AC/DC adapter: $\geq 0.35A$ PoE Input: $\geq 0.35A$
	maximum tolerances	AC/DC adapter: 48 V DC PoE Input: 37~57 V
	Overload current protection on the device	Non-replaceable fuse
Climatic conditions during operation	Minimum clearance around the device	Top and bottom device side: 10 cm (3.94 in) Left and right device side: 2 cm (0.79 in)
	Ambient air temperature	0°C ... +45°C (+32°F ... +113°F)
	Humidity	5% to 95% non-condensing
Climatic conditions during storage	Ambient air temperature	-40°C ... +70°C (-40°F ... +158°F)
	Humidity	5% to 95% non-condensing
Pollution degree	2	
Protection classes	Laser protection	Class 1 in compliance with IEC 60825-1
	Degree of protection	IP41

Dimensions W x H x D	DAP640	See "Dimension drawings" on page 42
Weight		0.74 kg (1.631 lb)
Supply voltage	Connection type	AC/DC adapter PoE Input
	Rated voltage	AC/DC adapter: 48 V DC PoE Input: 48 V
	Rated current	AC/DC adapter: ≥0.5A PoE Input: ≥0.6A
	maximum tolerances	AC/DC adapter: 48 V DC PoE Input: 42.5~57 V
	Overload current protection on the device	Non-replaceable fuse
Climatic conditions during operation	Minimum clearance around the device	Top and bottom device side: 10 cm (3.94 in) Left and right device side: 2 cm (0.79 in)
	Ambient air temperature	0°C ... +50°C (+32°F ... +122°F)
	Humidity	5% to 95% non-condensing
Climatic conditions during storage	Ambient air temperature	-40°C ... +70°C (-40°F ... +158°F)
	Humidity	5% to 95% non-condensing
Pollution degree		2
Protection classes	Laser protection	Class 1 in compliance with IEC 60825-1
	Degree of protection	IP41

# 8.2 Dimension drawings

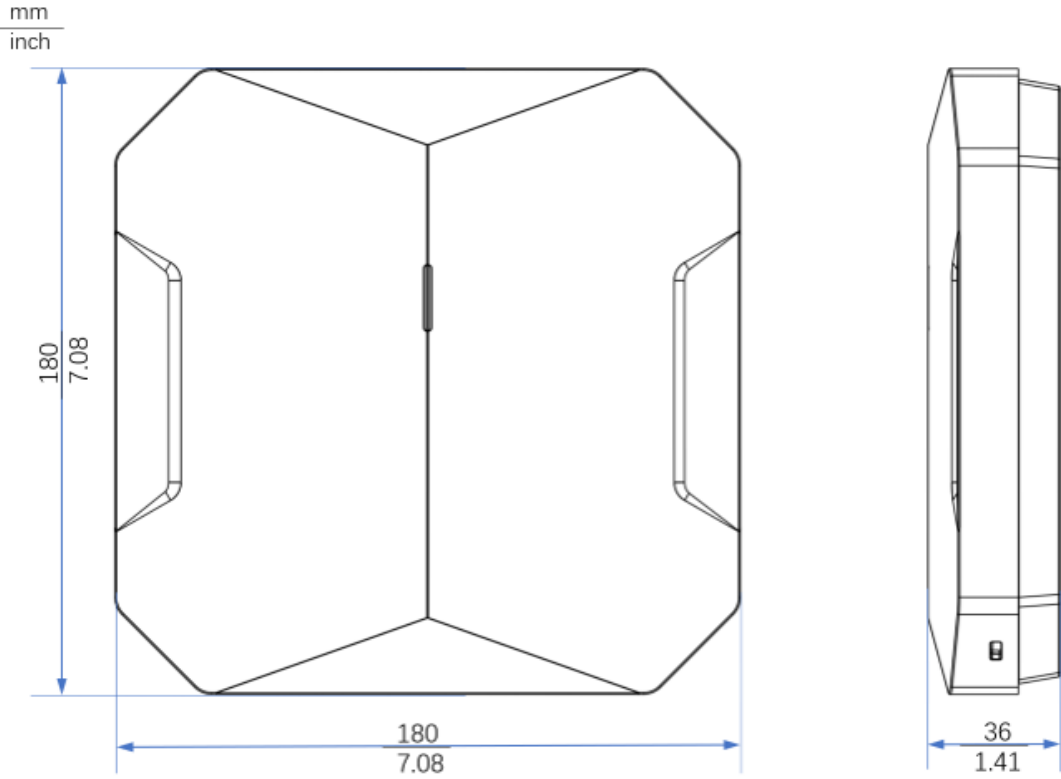

## 8.3 WLAN module specifications

### 8.3.1 Radio technology

Range	Depending on the antenna used, frequency range and data rate
Encryption	<ul style="list-style-type: none"><li>▶ Static WEP</li><li>▶ WPA3 Personal</li><li>▶ WPA2 Personal</li><li>▶ WPA Personal</li><li>▶ 802.1x/EAP</li><li>▶ WPA3 Enterprise</li><li>▶ WPA2 Enterprise</li></ul>
Frequency range	<ul style="list-style-type: none"><li>▶ Support of 2.4 GHz: 2400 MHz to 2483.5 MHz</li><li>▶ Support of 5 GHz: 5150 MHz to 5250 MHz 、 5250 MHz to 5350 MHz、 5470 MHz to 5725 MHz、 5725 MHz to 5850 MHz</li></ul>
Modulation technology	<ul style="list-style-type: none"><li>▶ 802.11b: BPSK, QPSK, CCK</li><li>▶ 802.11a/g/n/ac: BPSK, QPSK, 16-QAM, 64-QAM, 256-QAM</li><li>▶ 802.11ax: BPSK, QPSK, CCK, 16-QAM, 64-QAM, 256-QAM, 1024-QAM</li></ul>
Radio topology	▶ WLAN Access-Point, MESH, Bridge

### 8.3.2 Roaming

- ▶ IEEE 802.11k(Radio Resource Measurement)
- ▶ IEEE 802.11v(Wireless Network Management)
- ▶ IEEE 802.11r(Fast Roaming)
- ▶ OKC (Opportunistic Key Caching)
- ▶ PMK Caching

### 8.3.3 Receiving sensitivity, transmit power, and data rate of the WLAN module

The values shown in the following tables are the maximum values of the WLAN module. The values are in no case to be perceived as a guaranteed property of the overall product. For some country profiles, the module reduces data rate and transmit power automatically. The reason for are national standards.

#### DAP620

RF performance table				
Rate	Receive sensitivity (per chain)		Maximum transmit power (per chain)*	
	2.4 GHz	5 GHz	2.4 GHz	5 GHz
1 Mb/s	-97		18 dBm	
11 Mb/s	-90		18 dBm	
6 Mb/s	-93	-93	18 dBm	18 dBm
54 Mb/s	-76	-77	16 dBm	16 dBm
HT20 (MCS0/8)	-93	-93	18 dBm	18 dBm
HT20 (MCS7/15)	-73	-76	15 dBm	15 dBm
HT40 (MCS0/8)	-91	-91	18 dBm	18 dBm
HT40 (MCS7/15)	-72	-74	15 dBm	15 dBm
VHT20 (MCS0)	-93	-93	18 dBm	18 dBm
VHT20 (MCS8)	-71	-73	14 dBm	15 dBm
VHT40 (MCS0)	-91	-91	18 dBm	18 dBm
VHT40 (MCS9)	-67	-68	14 dBm	15 dBm
VHT80 (MCS0)		-88		18 dBm
VHT80 (MCS9)		-64		14 dBm
HE20 (MCS0)	-93	-93	18 dBm	18 dBm
HE20 (MCS11)	-64	-65	14 dBm	15 dBm
HE40 (MCS0)	-90	-91	18 dBm	18 dBm
HE40 (MCS11)	-62	-62	14 dBm	15 dBm
HE80 (MCS0)		-88		18 dBm
HE80 (MCS11)		-59		14 dBm

#### DAP640

RF performance table				
Rate	Receive sensitivity (per chain)		Maximum transmit power (per chain)*	
	2.4 GHz	5 GHz	2.4 GHz	5 GHz
1 Mb/s	-99		18 dBm	
11 Mb/s	-90		18 dBm	
6 Mb/s	-93	-93	17 dBm	18 dBm
54 Mb/s	-77	-77	16 dBm	16 dBm
HT20 (MCS0/8)	-93	-93	17 dBm	17 dBm
HT20 (MCS7/15)	-76	-74	14 dBm	15 dBm
HT40 (MCS0/8)	-91	-90	17 dBm	17 dBm
HT40 (MCS7/15)	-74	-71	14 dBm	15 dBm
VHT20 (MCS0)	-93	-93	17 dBm	17 dBm
VHT20 (MCS8)	-72	-70	14 dBm	15 dBm
VHT40 (MCS0)	-91	-90	17 dBm	17 dBm
VHT40 (MCS9)	-68	-66	14 dBm	15 dBm
VHT80 (MCS0)		-87		17 dBm
VHT80 (MCS9)		-62		15 dBm
HE20 (MCS0)	-94	-93	17 dBm	17 dBm
HE20 (MCS11)	-65	-65	12 dBm	13 dBm
HE40 (MCS0)	-91	-91	17 dBm	17 dBm
HE40 (MCS11)	-62	-62	12 dBm	13 dBm
HE80 (MCS0)		-88		17 dBm
HE80 (MCS11)		-59		13 dBm

## 8.4 EMC

EMC interference immunity			
EN 61000-4-2	Electrostatic discharge		
EN 60601-1-2	Contact discharge, test level 4		8 kV
	Air discharge, test level 4		15 kV
EN 61000-4-3	Electromagnetic field		
EN 60601-1-2	80 MHz ... 3000 MHz		max. 10 V/m
	3000 MHz ... 6000 MHz		3 V/m
EN 61000-4-4	Fast transients (burst), test level 4		
EN 60601-1-2	Power line		2 kV
	Data line		1 kV
EN 61000-4-5	Voltage surges		
EN 60601-1-2	Power line	line/line	1 kV
	Power line	line/ground	2 kV
	Data line	line/ground	2 kV
EN 61000-4-6	Conducted interference voltages, test level		
EN 60601-1-2	3		
	150 kHz ... 80 MHz		6 V
EMC interference emission			
EN 55032	Class B		
FCC 47 CFR Part 15	Class B		

## 8.5 Mechanical

Immunity	
Vibration	IEC 60068-2-6 Test FC test level according to IEC 61131-2
	IEC 60068-2-64 test level in accordance with IEC 61131-2
Shock	IEC 60068-2-27 Test Ea test level in accordance with IEC 61131-2

## 8.6 Network range

### 10/100/1000/2500 Mbit/s twisted pair port

Length of a twisted pair segment                      max. 100 m (328 ft) (for Cat5e cable)

*Network range: 10/100/1000/2500 Mbit/s twisted pair port*

## 8.7 Power consumption/power output

Name	Maximum power consumption	Power output
DAP620	13 W	44.35 Btu (IT)/h
DAP640	24.8W (802.3at)	84.61 Btu (IT)/h



## 9 Scope of delivery

Number	Article
1 x	Device
1 x	Qualification
1 x	Mounting kit

## 10 Order number

Device	Order number
DAP620	942 999-300
DAP640	942 999-304

# 11 Underlying technical standards

Name	
CAN/CSA 22.2 No. 62368-1	Information Technology Equipment - Safety - Part 1: General Requirements
EN 300 328	Electromagnetic compatibility and radio spectrum matters (ERM) - bandwidth transfer systems - data transmission equipment operating in 2.4 GHz ISM band and using spread spectrum modulation technology
EN 301 893	Broadband radio access networks (BRAN) - 5 GHz high performance Remote Local Area Network (RLAN)
EN 301 489-1	Electromagnetic compatibility for radio equipment and services
EN 301 489-17	Electromagnetic compatibility (EMC) for radio equipment and services - specific conditions for 2.4 GHz broadband transmission systems and 5 GHz high-performance RLAN equipment
UL 62368-1	Audio/video, information and communication technology equipment - Part 1: Safety requirements
EN 55032	Electromagnetic compatibility of multimedia equipment - Emission Requirements
IEC/EN 62368-1	Equipment for audio/video, information and communication technology - Part 1: safety requirements
FCC 47 CFR Part 15	Code of Federal Regulations
EN 60601-1-1	Medical electrical equipment -Part 1: General requirements for safety – Collateral standard - Safety requirements for medical electrical systems
EN 60601-1-2	Medical electrical equipment -Part 1-2: General requirements for basic safety and essential performance - Collateral Standard: Electromagnetic disturbances - Requirements and tests
Wi-Fi 6	IEEE 802.11ax - IEEE Standard for Information Technology- Telecommunications and Information Exchange between Systems Local and Metropolitan Area Networks--Specific Requirements Part 11: Wireless LAN Medium Access Control (MAC) and Physical Layer (PHY) Specifications Amendment 1: Enhancements for High-Efficiency WLAN

The device has an approval based on a specific standard exclusively if the approval indicator appears on the device casing.

The device generally fulfills the technical standards named in their current versions.

# **A Further support**

## **Technical questions**

For technical questions, please contact any Hirschmann IT dealer in your area or Hirschmann IT directly

You find the addresses of our partners on the Internet at <https://catalog.belden.com/>

A list of local telephone numbers and email addresses for technical support directly from Hirschmann IT is available at <https://catalog.belden.com/>

This site also includes a free of charge knowledge base and a software download section.

# HIRSCHMANN IT

---

A **BELDEN** BRAND