



HIRSCHMANN

A **BELDEN** BRAND

User Manual

WLAN Outdoor Guide

The naming of copyrighted trademarks in this manual, even when not specially indicated, should not be taken to mean that these names may be considered as free in the sense of the trademark and tradename protection law and hence that they may be freely used by anyone.

© 2020 Hirschmann Automation and Control GmbH

Manuals and software are protected by copyright. All rights reserved. The copying, reproduction, translation, conversion into any electronic medium or machine scannable form is not permitted, either in whole or in part. An exception is the preparation of a backup copy of the software for your own use.

The performance features described here are binding only if they have been expressly agreed when the contract was made. This document was produced by Hirschmann Automation and Control GmbH according to the best of the company's knowledge. Hirschmann reserves the right to change the contents of this document without prior notice. Hirschmann can give no guarantee in respect of the correctness or accuracy of the information in this document.

Hirschmann can accept no responsibility for damages, resulting from the use of the network components or the associated operating software. In addition, we refer to the conditions of use specified in the license contract.

You can get the latest version of this manual on the Internet at the Hirschmann product site (www.hirschmann.com).

Hirschmann Automation and Control GmbH
Stuttgarter Str. 45-51
72654 Neckartenzlingen
Germany

Contents

	Safety instructions	5
	About this manual	7
1	Introduction	9
1.1	Device Roles	10
1.1.1	Access Point	11
1.1.2	WLAN Bridge (point-to-point)	12
1.1.3	WLAN Bridge Relay	13
1.1.4	WLAN Distribution Point - (Point-to-Multipoint)	14
1.1.5	WLAN Client	15
1.1.6	WLAN Roaming Clients	16
1.2	Components of the WLAN system	17
1.2.1	Access Points	17
1.2.2	Power supply to the Access Points	18
1.2.3	External antennas	18
1.2.4	Components for lightning protection and surge protection	19
1.3	Selecting the frequency band	20
1.3.1	2.4 GHz band or 5 GHz band	20
1.3.2	Special regulations for the 5 GHz band	21
2	Setting up P2P connections	27
2.1	The Antenna Calculator	29
2.1.1	Data throughput: Nominal vs. Actual	29
2.2	Geometric dimensioning of P2P links	30
2.3	Antenna alignment	34
2.4	Measuring wireless bridges	38
3	Lightning protection and surge protection	39
3.1	Formation of lightning discharges	40
3.2	External lightning protection	43

3.3	Internal lightning protection	44
3.4	Selecting the components for lightning protection and surge protection	47
3.4.1	Classification of surge protective devices	47
3.4.2	External lightning protection	48
3.4.3	Internal lightning protection	49
3.4.4	Example applications	50
4	Installation	57
4.1	Mounting Notes	58
4.2	Mounting the Access Points	60
4.2.1	Selecting the location for mounting	61
4.2.2	Installing the device onto or on a flat surface	61
4.2.3	Installing the device on a pole	62
4.3	Mounting antennas	63
4.3.1	Selecting the location for mounting	64
4.3.2	Flat surface mounting	65
4.3.3	Pole mounting	66
4.4	Mounting the lightning rods	67
4.4.1	Dimensioning of the lightning rod	68
4.4.2	Distance to the components at risk	68
4.4.3	Lightning charge conduction (grounding)	70
A	Appendix	71
A.1	Antenna characteristics	72
A.2	Troubleshooting	73
B	Further support	75

Safety instructions

■ Notes on safety

This manual contains instructions to be observed for ensuring your personal safety and for preventing damage. The warnings appear next to a warning triangle with a different heading depending on the degree of danger posed:



Danger!

Means that death, serious physical injury or significant damage to property **will occur** if the corresponding safety measures are not carried out.



Warning!

Means that death, serious physical injury or significant damage to property **could occur** if the corresponding safety measures are not carried out.



Caution!

Means that minor physical injury or damage to property can occur if the required safety measures are not carried out.

Note: Contains important information on the product, on how to manage the product, or on the respective section of the documentation to which your special attention is being drawn.

About this manual

The advantages of wireless LANs (WLANs) are obvious – they offer flexibility, mobility and convenience at a lower cost than cabled networks. WLANs can be quickly installed without any changes to the construction of the building, and they offer new applications not available with cabled LANs. Access Points in combination with suitable antennas are ideal for setting up WLANs, either indoors or outdoors.

This document applies for all BAT Access Points in combination with appropriate antennas and it provides general information on the outdoor operation of wireless LAN systems. Information on the installation and basic configuration of the various Access Points and antennas is available from the corresponding installation manual.

Note: Protecting the components employed from the consequences of lightning strikes and other electrostatic influences is one of the most important aspects to be considered when designing and installing wireless LAN systems for outdoor use. Please refer to the appropriate notes ([see on page 39 “Lightning protection and surge protection”](#)) as otherwise Hirschmann cannot provide any guarantee for damage to the components.

Note: Safety notices concerning the mounting and installation of WLAN system components are to be found at relevant locations in the following chapters.

1 Introduction

This chapter presents the basic scenarios for wireless local area network (WLAN) outdoor systems. It also lists the type of components required to set up a WLAN system outdoors.

1.1 Device Roles

Wireless local area networks (WLANs) can either extend or replace a traditional cable-based network. In some cases, a wireless LAN provides new application design possibilities, providing streamlined work flows and cost savings.

You can use the Access Point in many different roles, depending upon the specific features and the requirements of your network design. These roles include:

- ▶ **Access Point:**
The Access Point provides client devices with a means of wireless entry to a cable-based local area network.
- ▶ **WLAN Bridge:**
Two Access Points provide a wireless point-to-point communication link between two cable-based LANs.
- ▶ **WLAN Bridge Relay:**
One or more dual radio Access Points serve as message relay stations providing a communications link between two cable-based LANs.
- ▶ **WLAN Distribution Point:**
A single master Access Point connects multiple slave access points to a central LAN in a point-to-multipoint design.
- ▶ **WLAN Client:**
A Access Point is designed or configured to serve as an Ethernet adapter and provide a wireless communication link to a WLAN access point.
- ▶ **WLAN Roaming Client:**
WLAN clients wirelessly connect one or more mobile units as they move between multiple WLAN access points, providing continuous, dynamic communications.

Each of these roles is briefly described below. The following chapter describes how to configure a Access Point to perform each of these roles.

1.1.1 Access Point

The Access Point can act as a central Access Point, connected to multiple wireless clients. In this role, the Access Point provides client access to one or more wireless local area networks and regulates the following:

- ▶ Client's rights to access the WLANs
- ▶ Communication between the clients
- ▶ Access to networks linked to other networks

In larger scale WLAN scenarios (for example in companies with facilities extending between several buildings or floors) multiple access points can provide WLAN clients with access to a common, shared network. The clients can roam between the different Access Points, if necessary. Such a design is commonly referred to as campus coverage because this solution has been adopted by a large number of colleges and universities to provide students and staff with network access.

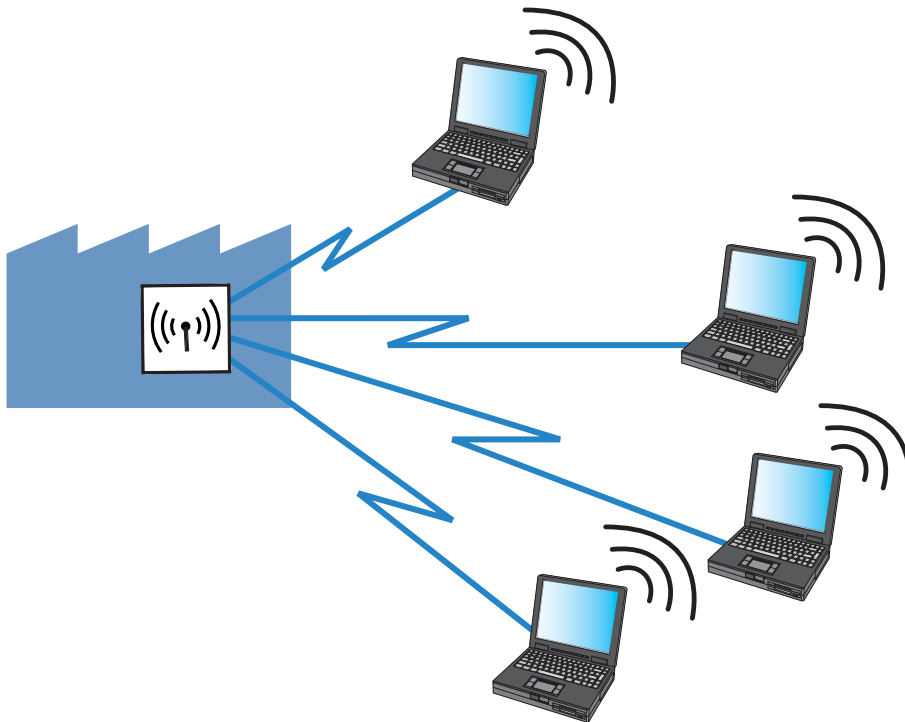

Figure 1: A single access point connected to wireless clients

1.1.2 WLAN Bridge (point-to-point)

Outdoor WLAN systems are especially useful for providing a point-to-point link between 2 Access Points. This design makes it possible, for example, to integrate a distant production building into the company network using 2 Access Points.



Figure 2: A wireless link between 2 Access Points

You can also use a point-to-point connection to span difficult terrain (such as mountainous areas or water) to provide network access in areas where cabling would be too expensive. With a direct line of sight between the 2 Access Points and a sufficient fresnel zone, you can bridge distances of several kilometers by this type of wireless link.

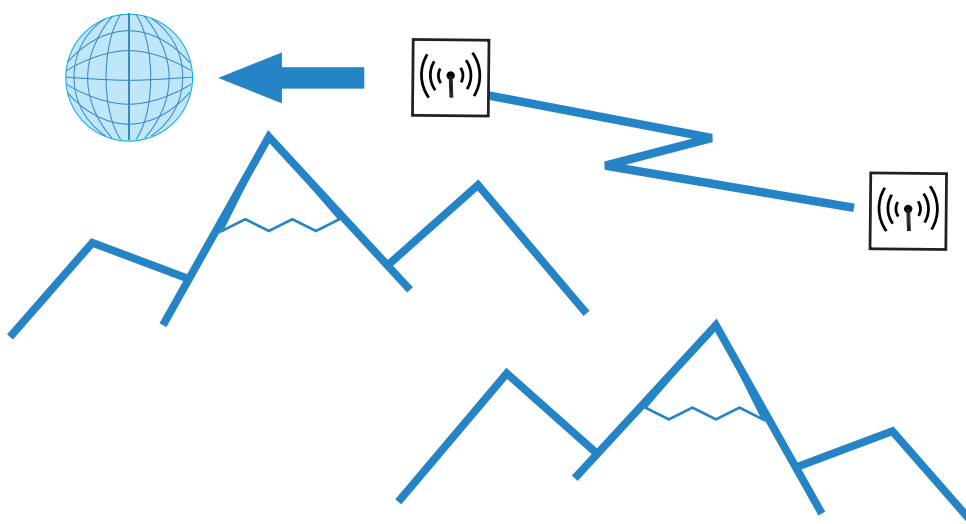

Figure 3: Point-to-point connection with a direct line of sight

1.1.3 WLAN Bridge Relay

Sometimes the required distance between 2 Access Points may exceed the maximum radio range of a wireless link. Also, physical obstacles may exist that prevent an uninterrupted line-of-sight connection between the Access Points. In these cases, you can connect the 2 end points by stringing together multiple Access Points, where each intermediate Access Point is equipped with 2 radio modules. Because the intermediate Access Points often operate only as relay stations, this design is referred to as "Relay mode".

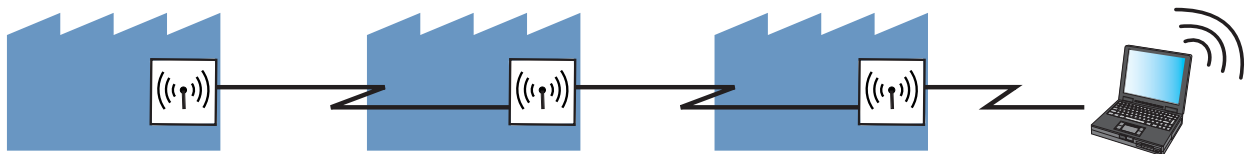

Figure 4: WLAN bridge in relay mode

BAT Access Points can run several point-to-point links simultaneously on each radio module, in addition to supporting WLAN clients. However, for performance reasons we recommended the use of BAT Access Points with 2 radio modules for the relay stations. If you use directional antennas, the relay station needs to be equipped with 2 radio modules.

1.1.4 WLAN Distribution Point - (Point-to-Multipoint)

A special type of wireless link is the connection of several distributed Access Points to a central – the point-to-multipoint (P2MP) WLAN or Wireless Distribution System (WDS). With this mode of operation you can establish connections for several buildings on the premises of a company with the central administrative building, for example. The central Access Point is configured as "master" and the remote stations as "slaves". All wireless links share the bandwidth of the central Access Point.

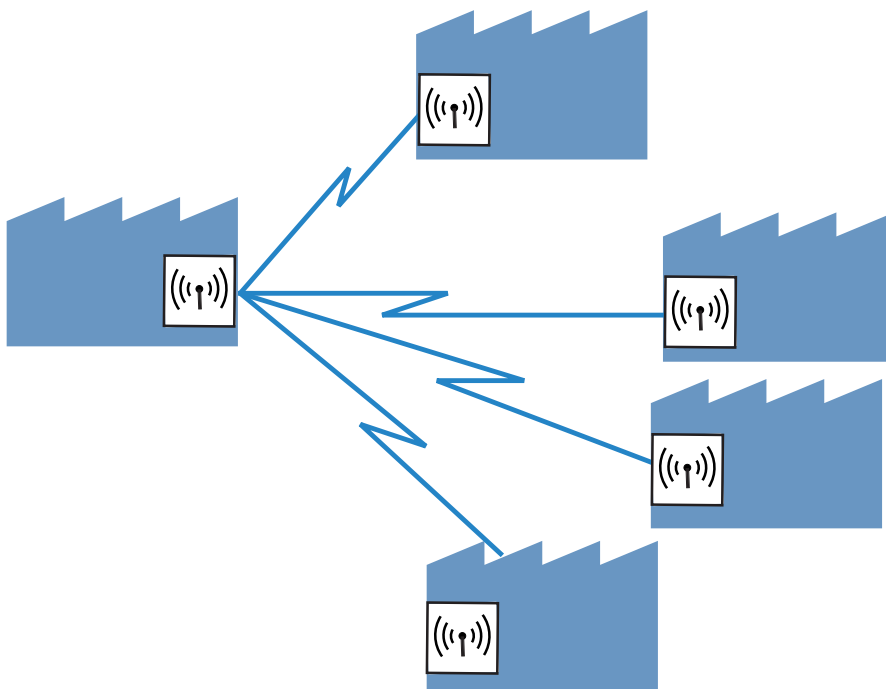

Figure 5: Point-to-multipoint wireless LAN

1.1.5 WLAN Client

A WLAN client can be either:

- ▶ equipped with an Ethernet interface (for example, a PC or printer), or
- ▶ an Access Point that is configured to serve as a conventional wireless LAN adapter, and avoids to use its full capability as an Access Point.

You can purchase special BAT access points that can operate exclusively as a WLAN client.

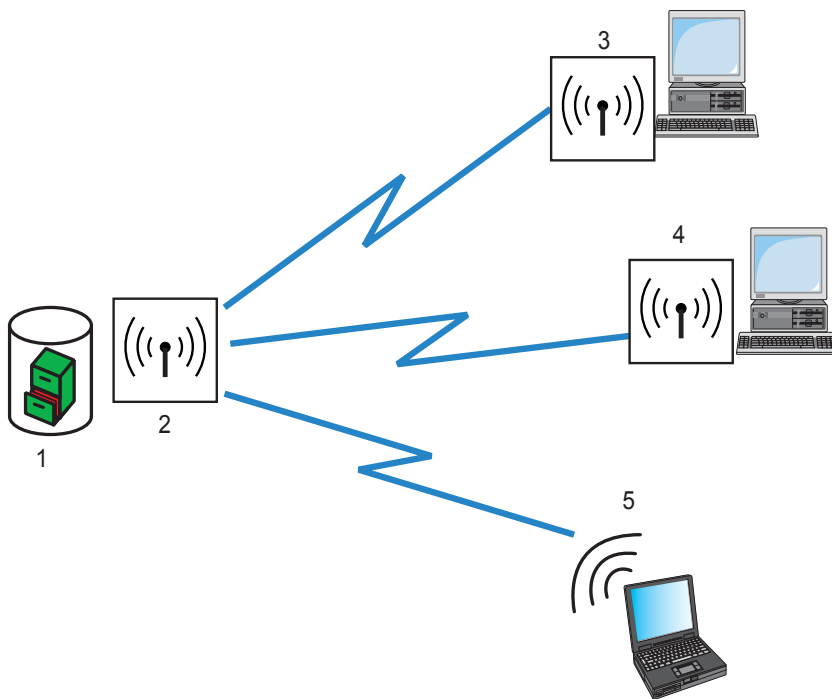

Figure 6: WLAN client

1 Authentication server, Authorization server, Accounting server

2 WLAN device in AP mode

3 WLAN device in client mode

4 WLAN device in client mode

5 End device in WLAN client mode

1.1.6 WLAN Roaming Clients

Using BAT Access Points, you can develop WLAN systems in industrial environments for the transmission of data to and from mobile objects. In the following logistics example, fork-lift trucks remain continuously connected to the company network via the WLAN. When combined with mobile barcode scanners, this system permits the real-time monitoring of the flow of inventory within a warehouse. Data obtained in this system pass through to an enterprise resource planning (ERP) system, which continuously provides up-to-the-minute information on current inventories

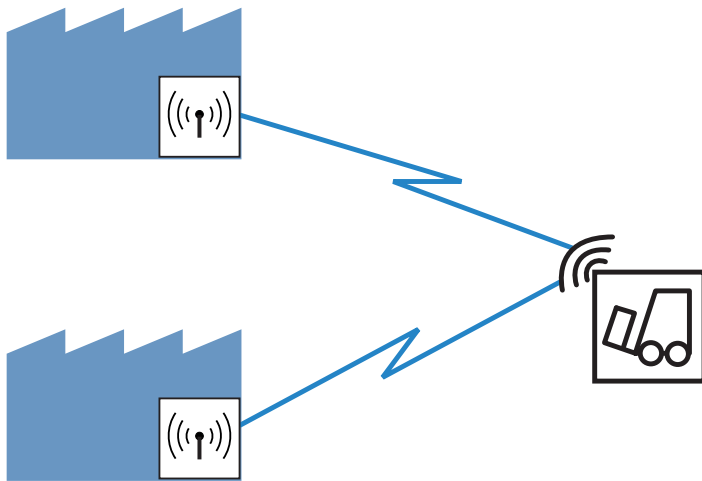

Figure 7: A WLAN client roaming between access points

1.2 Components of the WLAN system

An outdoor WLAN system consists of the following components:

1.2.1 Access Points

Hirschmann supplies Access Points for various applications. You can use Access Points to establish WLAN networks Service Set Identifiers (SSIDs) or wireless links point-to-point (P2P). Some models also provide router functionality, including a WAN interface.

The following characteristics are important when considering the use of WiFi devices:

- ▶ Environmental conditions: Some models are suitable for operation in an office environment (IP20), some are suitable for rugged conditions such as those found in logistics warehouses (IP40). Other models are designed for water resistance in extreme weather conditions (IP67) or for use in a very wide temperature range.
- ▶ Depending on model type, the Access Points support one of the following standards: IEEE 802.11a (5 GHz band), IEEE 802.11b or IEEE 802.11g (2.4 GHz band), IEEE 802.11n (2.4 GHz band and 5 GHz band) or IEEE 802.11ac (2.4 GHz band and 5 GHz band). The 5 GHz band is highly suitable for directional radio links due to the higher performance.
- ▶ Number of radio modules: For operating directional radio links over distances that exceed the range of a single point-to-point connection, such as when operating a relay, you can use devices fitted with 2 radio modules.

Note: Please refer to the appendix in this manual for more information on the frequency bands and their permitted use in different countries.

1.2.2 Power supply to the Access Points

Refer to the Installation Guide for further information.

The manual is available for download on the Internet: <https://www.doc.hirschmann.com>

1.2.3 External antennas

Refer to the Antenna Guide for further information.

The manual is available for download on the Internet: <https://www.doc.hirschmann.com>

1.2.4 Components for lightning protection and surge protection

Besides the central components (Access Point, antenna and power supply) the most important components are those for lightning protection and surge protection. Lightnings and other electrostatic occurrences can impinge on the WLAN system and cause harm to people, machines and equipment.

Hirschmann provides accessories (BAT-ANT-Protector m-f, BAT-LAN-Protector IP68) to be used as part of an installation of a lightning protection system for your outdoor installation. These accessories by themselves are part of a lightning protection solution. It is the responsibility of the lightning protection professional to take appropriate measures to reduce the risks due to electrostatic effects. Make sure the components are installed in accordance with local, regional and national regulations for codes and standards (IEC 62305 / DIN EN 62305 (VDE 0185-305)) and according to best practices for your application and environment.



DANGER

LIGHTNING STRIKE AND SURGE

Protect antennas installed outdoors with suitable lightning protection devices (for example lightning rods).

Install a surge protection device on every cable.

Failure to follow these instructions will result in death, serious injury, or equipment damage.

1.3 Selecting the frequency band

1.3.1 2.4 GHz band or 5 GHz band

One of the first steps in the planning of a WLAN system is to determine which frequency band to use. The following aspects are helpful for making this decision:

■ Advantages of the 2.4 GHz band

- ▶ Simple technical implementation with no need for functions such as Transmission Power Control (TPC) or Dynamic Frequency Selection (DFS).
- ▶ Widespread WLAN client base.
- ▶ Better transmission through obstacles (for example walls)

■ Disadvantages of the 2.4 GHz band

- ▶ Frequency band is also used by Bluetooth, microwave ovens, etc., and is thus prone to interference.
- ▶ There are 3 separate channels, meaning that 3 networks can be operated in parallel without interference.

■ Advantages of the 5 GHz band

- ▶ The frequency band is sparsely used, so that interference from other applications is uncommon.
- ▶ Depending on local regulations, there may be between 16 and 21 non-overlapping channels. This makes it possible to operate channel bundling or multiple overlapping radio cells.
- ▶ High ranges due to power levels of up to 1000 mW.

Note: You can use up to 4000 mW EIRP for applications in Broadband Fixed Wireless Access (BFWA): [See “Broadband Fixed Wireless Access \(BFWA\)” on page 23.](#)

■ **Disadvantages of the 5 GHz band**

- ▶ Regulations in Europe require techniques such as Dynamic Frequency Selection (DFS) for channel selection and Transmission Power Control (TPC) for power control.

Note: WLAN systems based on the 2.4 GHz band suit well to applications where WLAN clients need short-range connection to an Access Point (for example campus coverages, hot spots, transmission of data to mobile objects). The advantages of the 5 GHz band lie mainly with point-to-point systems, in which 2 Access Points can connect by a wireless link (WLAN bridge) over longer distances.

1.3.2 Special regulations for the 5 GHz band

With the 802.11h enhancement of September 2003, the private use of the 5 GHz band became possible outside closed spaces. To help protect military applications in the 5 GHz band, the European Telecommunications Standards Institute (ETSI) prescribed Dynamic Frequency Selection (DFS) and Transmission Power Control (TPC) procedures. However, when using DFS and TPC with a maximum of 1000 mW, or 4000 mW for commercial network operators in compliance with Broadband Fixed Wireless Access (BFWA) regulations, much higher transmission power can be generated than allowed by previous standards.

■ Dynamic Frequency Selection

If you want to use the maximum permitted performance of 1 watt in the 5 GHz band for outdoor use or 4 watts in Broadband Fixed Wireless Access (BFWA), you must comply with certain conditions. It is vital to avoid interference with radar systems that are active in this spectrum (for example meteorological, military). For this reason the European Telecommunications Standards Institute (ETSI) regulates WLAN devices operating in the 5 GHz band to employ the Dynamic Frequency Selection (DFS) mechanism.

With DFS, radar and WLAN systems can co-exist without interfering with one another and capacity utilization is spread evenly across available frequencies. When starting a wireless cell, the Access Point checks all channels for the presence of radar systems. The check uses an inactive period of 1 minute, during which the wireless cell is not available. During this interval, the Access Point generates a list of radar-free channels which is valid for 24 hours. The Access Point selects the best possible channel for operation from this list and continuously checks it for radar activity.

If a radar system subsequently starts operation, the device releases the channel immediately. In this case, the Access Point selects the next available channel, informs the participants in the wireless cell of the impending change, and switches to that channel.

Note: The currently selected channel can be used for any length of time, unless radar signals are detected. Only the restart of the radio cell interrupts the use of the channel in this case (for example due to device reconfiguration, firmware upload or reboot).

Note: If the system is able to respond to a channel switch instantaneously, the device repeats the check within 24 hours, following a 1-minute period of inactivity. The parameter "DFS Rescan Hours" (available in the HiLCOS menu tree under "Setup/Interfaces/WLAN/Radio settings") allows a time to be set for conducting the channel check assuming that the time is available, for example via Network Time Protocol (NTP).

Dynamic Frequency Selection (DFS) is mandatory for the frequency ranges from 5250 MHz to 5350 MHz, from 5470 MHz to 5725 MHz and from 5775 MHz to 5875 MHz in Broadband Fixed Wireless Access (BFWA). It is optional for the frequency range from 5150 MHz to 5250 MHz.

■ **Transmission Power Control**

Automatic adjustment of the transmit power reduces radio interference. When operating without Dynamic Frequency Selection (DFS) and Transmission Power Control (TPC) (at 5150 MHz to 5250 MHz), use a maximum of 200 mW EIRP. When operating Dynamic Frequency Selection (DFS) and Transmission Power Control (TPC), you have permission to use a maximum of 200 mW (at 5150 MHz to 5350 MHz) and 1000 mW EIRP (at 5470 MHz to 5725 MHz) as transmit power (as compared to 100 mW for 802.11b/g, 2.4 GHz, where DFS and TPC are unnecessary). The higher maximum transmit power compensates for the higher attenuation of 5 GHz radio waves in air and also allows for significantly longer ranges than in the 2.4 GHz range.

■ **Broadband Fixed Wireless Access (BFWA)**

In July 2007, Germany's Federal Network Agency released additional frequencies for broadband fixed wireless bridges in the 5 GHz band. These additional frequencies, located in the frequency range from 5755 MHz to 5875 MHz, are also referred to as Broadband Fixed Wireless Access (BFWA). You can use the additional frequencies for long-distance point-to-point (P2P) or point-to-multipoint (P2M) links to help provide high-speed Internet access to other users from a central node. You can use this method to help provide rural areas with high-speed Internet access.

Exclusively commercial providers may use the operation of BFWA. There are no charges for using these frequencies, but providers need to register at the Germany's Federal Network Agency. This band covers 120 MHz and offers 6 channels with a bandwidth of 20 MHz each. Maximum transmit power is 36 dBm or 4000 mW. Operating BFWA links requires Transmission Power Control (TPC) and Dynamic Frequency Selection (DFS).

■ **Available channels in the 5 GHz band**

In the available frequency range of 5.150 GHz to 5.875 GHz, you can use the following channels in Europe, divided into frequency ranges to which different conditions of use apply:

- ▶ 5150 MHz to 5250 MHz (channels 36, 40, 44, 48)
- ▶ 5250 MHz to 5350 MHz (channels 52, 56, 60, 64)

- ▶ 5470 MHz to 5725 MHz (channels 100, 104, 108, 112, 116, 132, 136, 140)
- ▶ 5755 MHz to 5875 MHz
 - Channels 151, 155, 159, 163, 167: In Germany only with Dynamic Frequency Selection (DFS) and only for commercial use in Broadband Fixed Wireless Access (BFWA).
 - Channels 149, 153, 157, 161, 165: For FCC use in the USA, without DFS.

Note: Channels 120, 124 and 128 were available in the past but are now blocked.

The following table shows which channels you can use in the different regions:

Channel	Frequency	ETSI (EU)	FCC (US)
36	5180 MHz	Yes	Yes
40	5200 MHz	Yes	Yes
44	5220 MHz	Yes	Yes
48	5240 MHz	Yes	Yes
52	5260 MHz	Yes	Yes
56	5280 MHz	Yes	Yes
60	5300 MHz	Yes	Yes
64	5320 MHz	Yes	Yes
100	5500 MHz	Yes	No
104	5520 MHz	Yes	No
108	5540 MHz	Yes	No
112	5560 MHz	Yes	No
116	5580 MHz	Yes	No
132	5660 MHz	Yes	No
136	5680 MHz	Yes	No
140	5700 MHz	Yes	No
147	5735 MHz	Yes *	No
149	5745 MHz	No	Yes
151	5755 MHz	Yes *	No
153	5765 MHz	No	Yes
155	5775 MHz	Yes *	No
157	5785 MHz	No	Yes
159	5795 MHz	Yes *	No
161	5805 MHz	No	Yes
163	5815 MHz	Yes *	No
165	5825 MHz	No	Yes

Channel	Frequency	ETSI (EU)	FCC (US)
167	5835 MHz	Yes *	No

* The frequency ranges and radio channels in band 3 underlie certain restrictions depending on country (for example, in Germany they are only permitted for public BFWA communications providers).

■ Frequency ranges for indoor use and outdoor use in the 5 GHz band

The use of the methods described in ETSI 301 893 for reducing mutual interference in the 5 GHz band (Transmission Power Control (TPC) and Dynamic Frequency Selection (DFS)) is mandatory for some fields of application. The following table provides information about the permitted use and corresponding transmission powers within the European Union (EU):

Frequency (GHz)	Transmit power (mW/dBm)	Use	DFS	TPC
5.15-5.25	200/23	Indoor	not mandatory	not mandatory
5.25-5.35	200/23	Indoor	mandatory	mandatory
5.470-5.725	1000/30	Indoor/Outdoor	mandatory	mandatory
5.755-5.875	4000/36	Outdoor (BFWA)	mandatory	mandatory

Note: Other regulations may apply for use in other countries. Please refer to the current wireless network regulations for the country in which you wish to operate a WLAN device, and set the country of operation in the WLAN settings.

The USA and Asia use frequency bands and maximum signal strengths that are different than the European standard.

In the USA, you can use 3 sub-bands, each 100 MHz wide, for wireless networks in the 5 GHz band. These are the "lower band" ranges from 5150 MHz to 5250 MHz, the "middle band" ranges from 5250 MHz to 5350 MHz and the "upper band" ranges from 5725 MHz to 5825 MHz. In the lower band, you have permission to use a maximum average EIRP of 50 mW; in the middle band this is 250 mW; and 1 W in the upper band.

2 Setting up P2P connections

This chapter introduces the basic principles involved in designing point-to-point links, and provides tips on aligning the antennas.

Note: Refer to the appendix for information on the frequency ranges used. For instructions on configuration of the Access Point, refer to the HiLCOS Configuration Guide.

The manual is available for download on the Internet: <https://www.doc.hirschmann.com>

BAT Access Points can serve as central stations in a wireless network, and also can also operate in point-to-point mode to bridge longer distances. For example, they can help provide a reliable connection between 2 networks that are several kilometers apart – without direct cabling or expensive leased land lines.

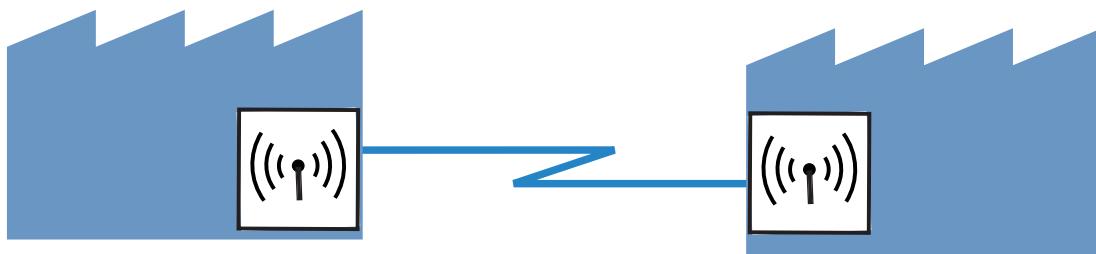

Figure 8: Point-to-point (WLAN bridge) connection

When you use Access Points and appropriately polarized antennas in accordance with IEEE 802.11n, you may establish 2 wireless links ("spatial streams") simultaneously between the end points of a point-to-point connection. This allows you to achieve higher data throughput, or to cover greater distances, than when using other standards.

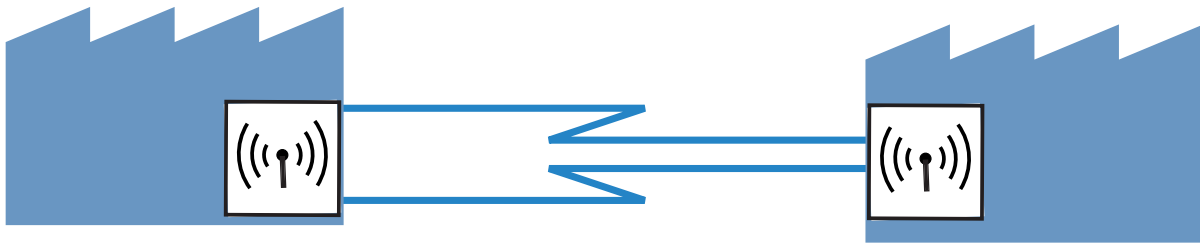

Figure 9: Usage of 2 spatial streams

2.1 The Antenna Calculator

You can use the Antenna Calculator to calculate the output power of the access points, as well as the achievable distances and data rates. You can download the program at www.hirschmann.com.

After selecting your components (Access Points, antennas, lightning protection and cable) the calculator works out the data rates, ranges, and antenna gain settings that you need for the configuration of the Access Points.

2.1.1 Data throughput: Nominal vs. Actual

The throughput for WLANs is called the "nominal data rate". This is the result of the signal quality and the WLAN standard you use and its method of modulation. Security methods and collision avoidance result in more overhead than in cabled networks. The actual data rate comes up to 50 % of the nominal data rate. 802.11g/a WLANs with a nominal data rate of 54 Mbps achieves a maximum net data rate of 24 Mbps. WLANs using the current 802.11n standard with 300 Mbps nominal data rate achieve a maximum net value of approximately 130 Mbps. Depending on the existing signal quality, WLAN systems may reduce their throughput performance step by step in order to counteract impairments in radio signals. When there is radio interference, packet retransmissions are necessary, leading to a reduction in net throughput. You need to consider time delays over distances of several kilometers, which require greater tolerances when they access the radio medium.

In the 5 GHz band it is helpful for you to configure one central access point as "master" and the other point-to-point partners as "slaves". Even in the 2.4 GHz band with automatic channel selection this setting helps to establish point-to-point connections.

2.2 Geometric dimensioning of P2P links

Answer the following basic questions when you design wireless links:

- ▶ Which antennas are suitable for the desired application? You can find answers to these questions with the help of the BAT Antenna Calculator ([see on page 29 “The Antenna Calculator”](#)).
- ▶ How do you align the antennas to enable reliable connections?
- ▶ What performance characteristics do the antennas need to provide sufficient data throughput within the legal regulations?

■ Positioning the antennas

Antennas broadcast their signals at a model-dependent angle. The spherical expansion of the signal waves produces amplification or interference of the effective power output at certain distances along the connection between the transmitter and receiver. The areas where the waves amplify or cancel themselves out are known as Fresnel zones.

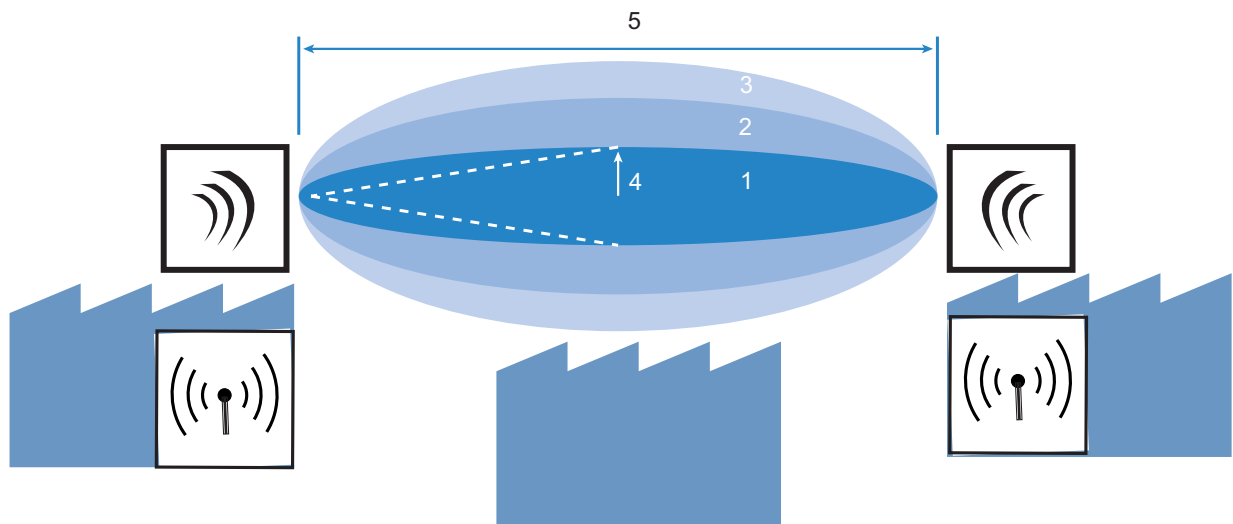

Figure 10: Fresnel zones

- 1 Fresnel zone 1
- 2 Fresnel zone 2
- 3 Fresnel zone 3
- 4 Radius
- 5 Distance

Ensure that Fresnel zone 1 is free from obstruction so that an acceptable level of output from the transmitting antenna reaches the receiving antenna. Any obstructing element protruding into this zone will significantly impair the effective signal power. The object screens off a portion of the Fresnel zone and the resulting reflections also lead to a significant reduction in signal reception.

You can calculate the radius (R[m]) of Fresnel zone 1 by using the following formula, assuming that you know the signal wavelength (l[m]) and the distance between transmitter and receiver (d[m]):

$$R = 0,5 * \sqrt{(\lambda * d)}$$

The wavelength in the 2.4 GHz band is approximately 0.125 m (0.41 ft), and in the 5 GHz band approximately 0.05 m (0.16 ft).

Example: With a separating distance of 8 km (5 miles) between the two antennas, the radius of Fresnel zone 1 in the 2.4 GHz band is 15.8 m (51.8 ft), and in the 5 GHz band is 10 m (32.8 ft).

So that the Fresnel zone 1 remains unobstructed, it is necessary that the height of the antennas is bigger than the highest obstruction within this radius. You can calculate the full height of the antenna mast (M) as depicted below:

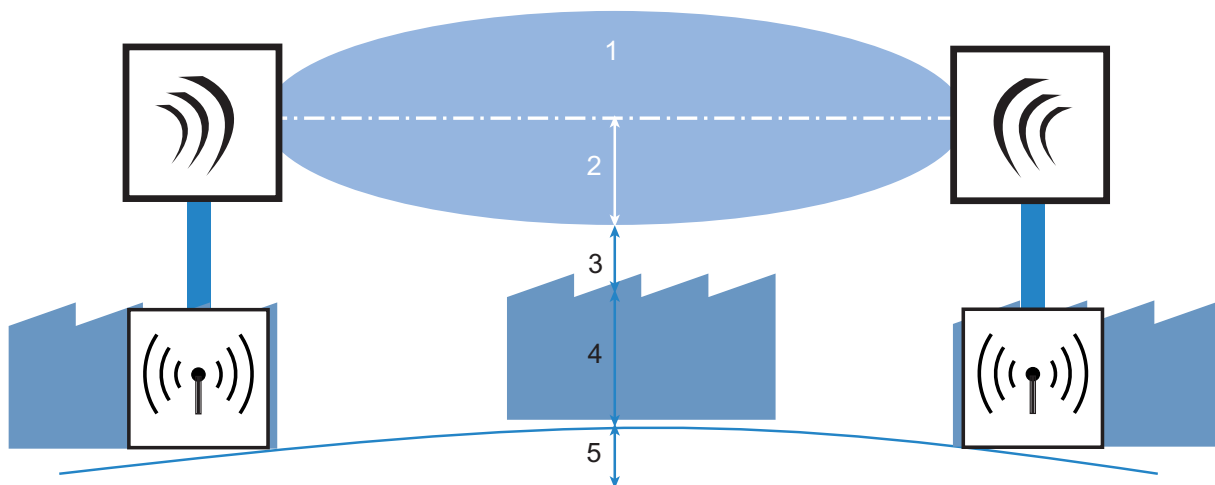

Figure 11: Mast height calculation

- 1 Fresnel zone
- 2 Radius R
- 3 Security: 1m
- 4 Obstruction height H
- 5 Earth curvature E

$$M = R + 1\text{m} + H + E \text{ (earth's curvature)}$$

You can calculate the allowance for the earth's curvature (E) at a distance (d) with the following formula for the metric length system:

$E[\text{m}] = d[\text{km}]^2 * 0.0147$ – e.g., at a distance of 8 km this is approximately 1 m.

For the anglo-american length system the formula is:

$E[\text{ft}] = d[\text{miles}]^2 * 0.1234$ – e.g., at a distance of 5 miles this is approximately 3.1 ft.

Example:

With a distance of 8 km (5 miles) between the antennas, the result in the 2.4 GHz band is a mast height above the level of the highest obstruction of approximately 17.8 m (58.4 ft), and in the 5 GHz band 12 m (39.4 ft).

Note: You can compute the necessary mast heights with the BAT Antenna Calculator.

■ Antenna power

Ensure that the power of the antennas is high enough to allow acceptable data transfer rates. In addition, the antenna power needs to comply with the country-specific legal regulations regarding maximum transmission power.

The calculation of effective power considers everything from the radio module in the transmitting access point to the radio module in the receiving access point. In between there are attenuating elements such as the cable, plug connections and the air transmitting the signals, as well as amplifying elements such as the external antennas.

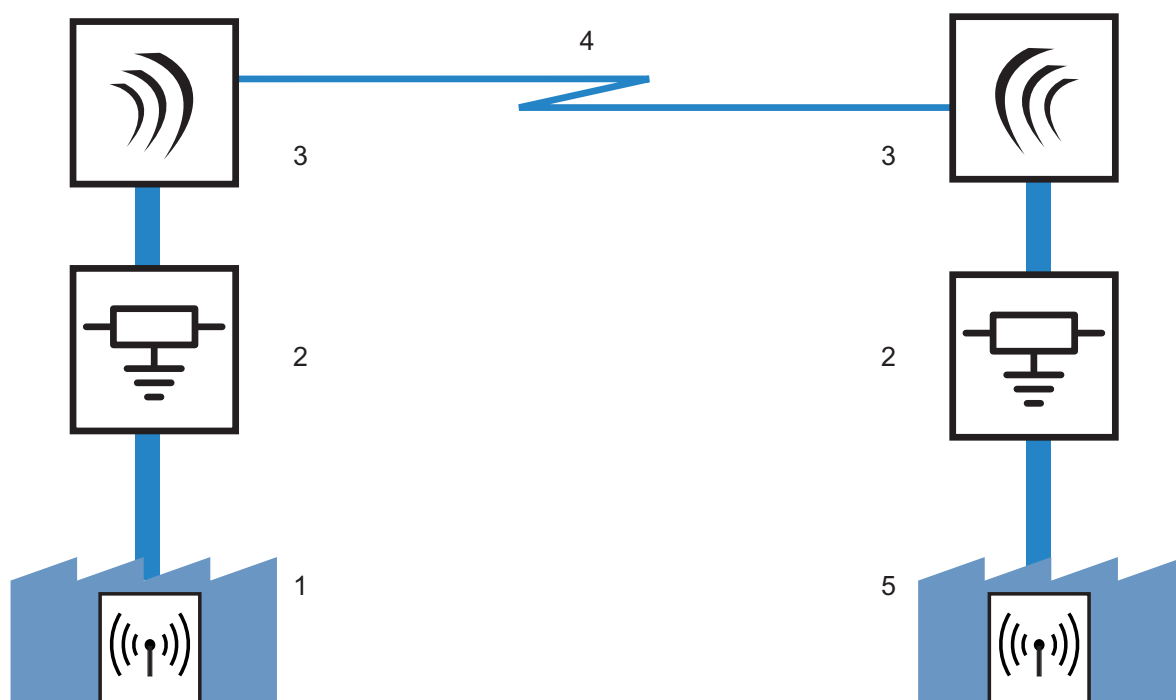

Figure 12: Elements influencing power

- 1 Output power of the radio module
- 2 Loss through cable, plugs and surge protection
- 3 Amplification with antenna gain
- 4 Free-space loss
- 5 Input signal at the radio module

2.3 Antenna alignment

The precise alignment of the antennas is important in establishing P2P connections. The more central you locate the receiving antenna in the "ideal line" of the transmitting antenna, the better the actual performance and effective bandwidth. As shown in the following illustration, if the receiving antenna is outside of this ideal area (1) significant losses in performance (2) will be the result.

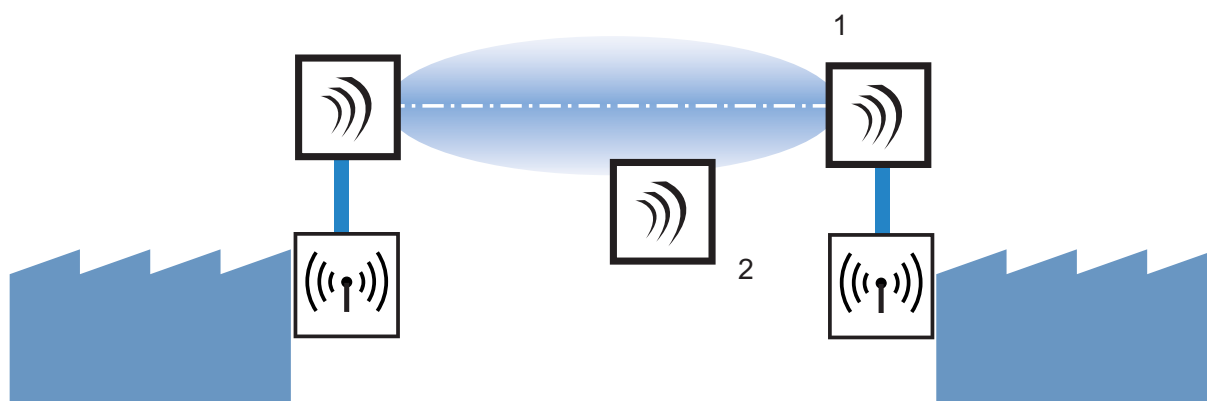

Figure 13: Antenna alignment

Note: You can find further information on the geometrical design of wireless paths and the alignment of antennas with LANconfig in the HiLCOS Configuration Guide.

The manual is available for download on the Internet: <https://www.doc.hirschmann.com>

You can display the current signal quality over a P2P connection device's LEDs, or in the LANmonitor, to help find the optimal alignment for the antennas.

You can activate the display of signal quality on the LEDs for the WLAN interface (LANconfig: WLAN > General > Physical WLAN settings > Operation). The faster the LED blinks, the better the connection (a blinking frequency of 1 Hz represents a signal quality of 10 dB, double this frequency indicates that the signal strength is twice as high).

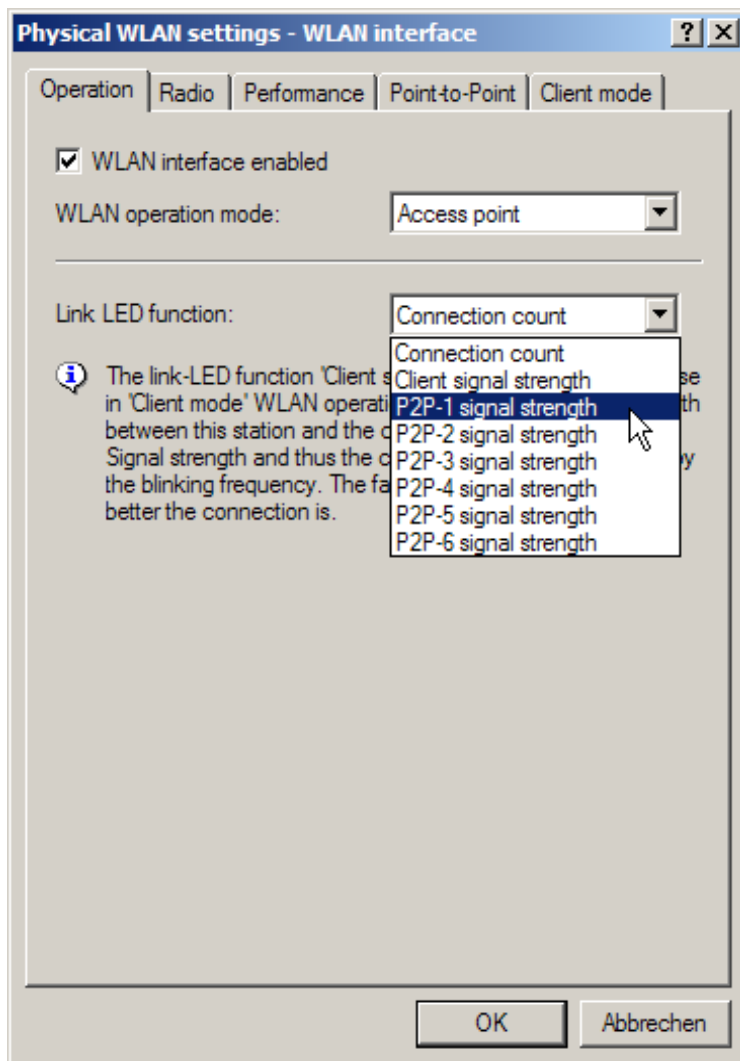

Figure 14: Link LED function in physical WLAN settings in LANconfig

In LANmonitor, you can open the connection quality display by using the context menu. Right-clicking with the mouse on 'Point-to-point' activates the option 'Adjusting Point-to-Point WLAN Antennas...

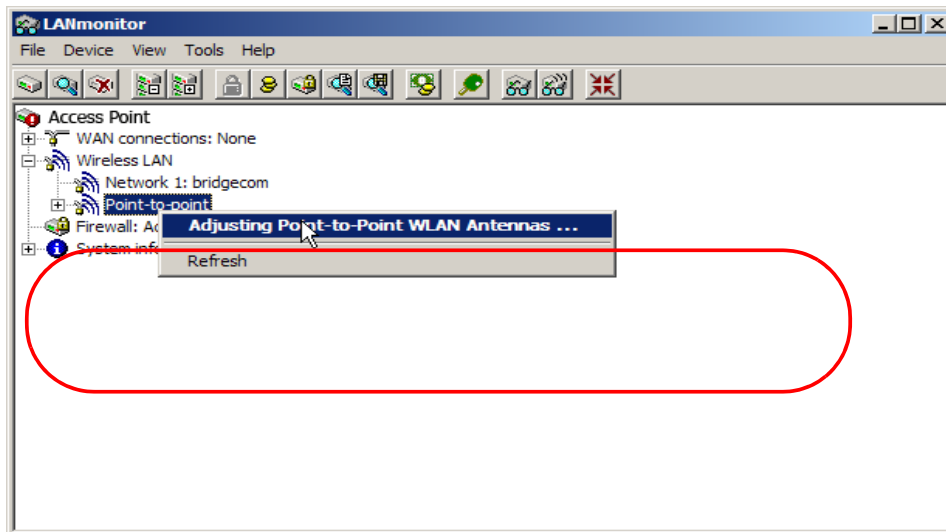

Figure 15: Adjusting Point-to-Point WLAN antennas in LANConfig

Note: The 'Point-to-Point' entry is visible in the LANmonitor if the monitored device has at least one base station defined as a remote site for a P2P connection (LANconfig: WLAN > General > Physical WLAN settings > Point-to-Point).

In the dialog for setting up point-to-point connections, LANmonitor prompts for the information necessary to establish the P2P connection:

- ▶ Is the P2P connection configured at both ends with MAC address or station name of the remote base station?
- ▶ Is the point-to-point mode of operation activated?
- ▶ Which access point do you want to monitor? Select any of the base stations defined as P2P remote sites in the device.
- ▶ Are both antennas approximately aligned? Ensure that the basic P2P connection work before you can perform fine-tuning with the aid of LANmonitor.

Once signal monitoring has commenced, the P2P dialog displays the absolute values for the current signal strength and the maximum value since starting the measurement. LANmonitor displays the development of the signal strength over time and the maximum value, as shown below:

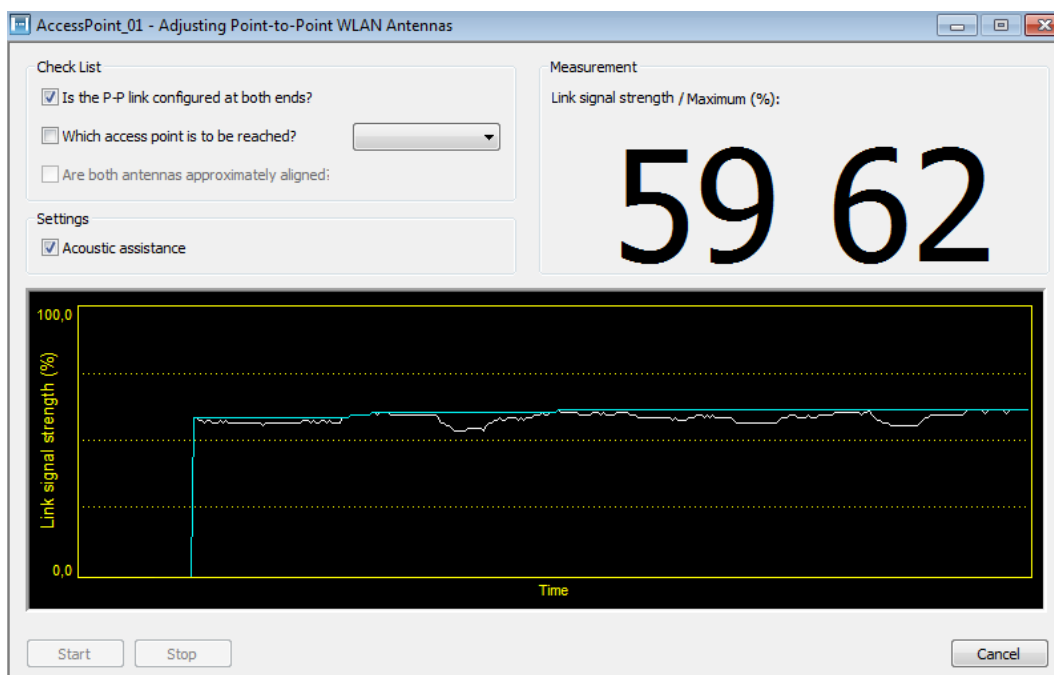

Figure 16: Diagram displaying the development of signal strength

Initially adjust one of the two antennas until a maximum value is achieved. Then secure this first antenna and adjust the second antenna to attain the optimal signal quality.

2.4 Measuring wireless bridges

After planning and installation, you can analyze the wireless bridge with a benchmark program (for example iPerf) to determine the actual data throughput.

3 Lightning protection and surge protection

When you mount devices or antennas outdoors, there is a risk of them being struck by a lightning strike. Additionally, surges may get into the interior of the building. Assign a lightning protection professional to implement the necessary measures to reduce these risks. The lightning protection professional installs the equipment in accordance with local, regional and national regulations for codes and standards (such as IEC 62305 / DIN EN 62305 (VDE 0185-305)) and according to best practices for your application and environment.



DANGER

LIGHTNING STRIKE AND SURGE

Protect antennas installed outdoors with suitable lightning protection devices (for example lightning rods).

Install a surge protection device on every cable.

Failure to follow these instructions will result in death, serious injury, or equipment damage.

3.1 Formation of lightning discharges

Lightning flashes are electromagnetic discharges that are caused by differences in electric potential. Water particles are charged through friction when there is weather movement in the atmosphere. The predominantly positively charged particles rise upwards while the negatively charged particles tend to remain at the lower levels. This uneven distribution of electrical charge can cause discharges within the clouds that can be observed as cloud-to-cloud lightning.

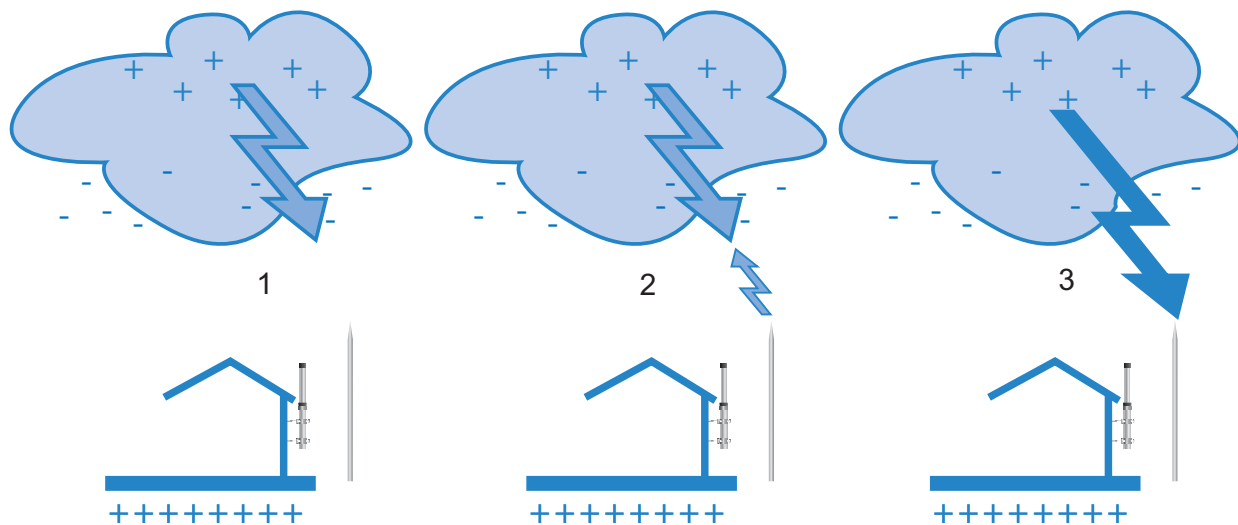

Figure 17: Formation of lightning discharges
1 Leader lightning
2 Conductive discharge
3 Lightning discharge

As the earth is predominantly positively charged, a difference between the potential of the cloud and the earth arises. As soon as this potential difference is large enough, leader lightning descends earthwards.

■ **Direct lightning strike**

The most frequent type of lightning is cloud-earth lightning. A so-called lightning leader develops from a negatively charged center of a thundercloud. This leader descends, and when it is between 10 m and several 100 m from the earth the electrical field strength increases so strongly in exposed places – for example at the roof of a house or top of a tree or even the tip of an antenna – that similar and opposite discharges to the lightning leader develop there, the so-called conductive discharges. One of possibly many conductive discharges meets the lightning leader and "earths" it. This determines the point where lightning strikes.

If an antenna is struck by lightning, the instant increase in voltage is conducted via the coaxial cable to any connected devices which generally results in the destruction of the devices. In a WLAN system, for example, this is the Access Point. Additionally, any ungrounded components of a WLAN system may be subject to sparks or arcs to any earthed metal parts in the vicinity.

■ **Partial discharges**

Even if a conductive discharge originates in an antenna it does not necessarily mean that lightning will strike the antenna. In order to feed the conductive discharge in the antenna, a momentary electrical impulse flows through the antenna system – this is called a partial discharge. A partial discharge is therefore a conductive discharge without leading to a direct lightning strike. These partial discharges can also result in damage to connected electronic equipment such as Access Points unless you take protective measures.



DANGER

INVISIBLE ELECTRICAL DISCHARGES

Even when there are no visible phenomena such as thunderstorms or a direct lightning strike, invisible electrical discharges from the atmosphere can still occur. These invisible electrical discharges can destroy or damage sensitive radio modules or other electronic devices.

Failure to follow these instructions will result in death, serious injury, or equipment damage.

■ **Risks to antennas**

Antennas for wireless LAN systems are at particular risk from lightning strike as they tend to be mounted in exposed positions and they are designed to be very good electrical conductors.

The more pointed, needle-shaped and exposed antennas are, the greater the danger posed by a conductive discharge that could result in a direct lightning strike or partial discharge.

Note: Please note that the explanations of lightning protection in this documentation only refer to protection for wireless LAN systems. Ensure to plan and install the protection of the buildings themselves and other equipment and associated networks (LANs) separately, if necessary.

3.2 External lightning protection

External lightning protection includes all measures for you to prevent a direct lightning strike in the equipment to be protected. This includes, for example, arrester equipment such as lightning rods which intentionally offer an exposed point for electrical discharges. Any lightning that strikes this arrester equipment is channeled by a conductor along the shortest path to the grounding system. Intentionally "catching" the lightning with the arresting equipment creates a protected area where direct lightning strike is impossible. The actual design and construction of the external lightning protection depends on the prevailing structural circumstances.

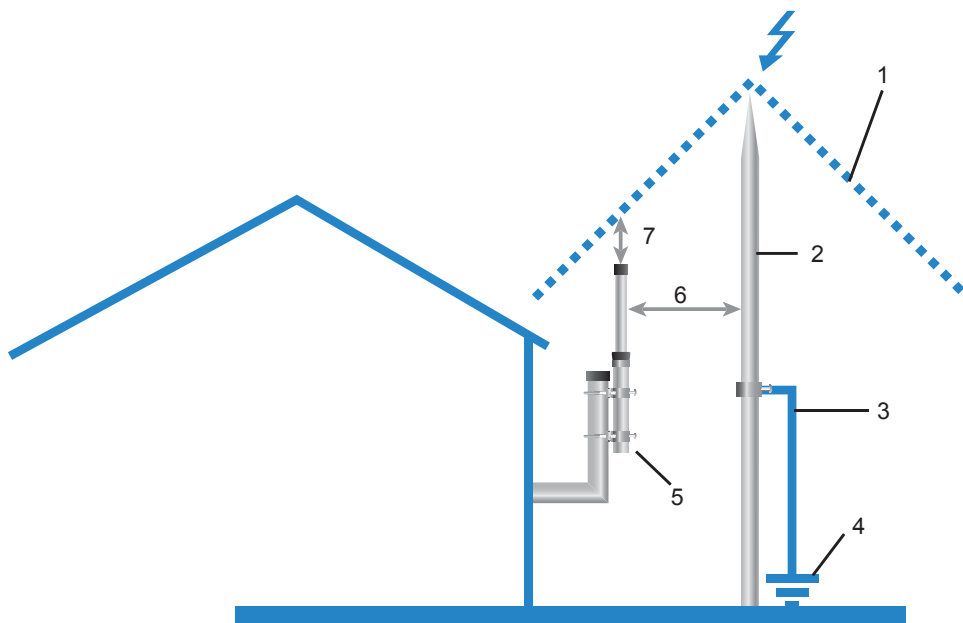

Figure 18: External lightning protection

- 1 Area protected by insulated lightning protection system (LPS)
- 2 Lightning rod
- 3 Conductor
- 4 Grounding
- 5 Antenna
- 6 Safety clearance according to IEC 62305 / DIN EN 62305 (VDE 0185-305)
- 7 Separation distance according to IEC 62305 / DIN EN 62305 (VDE 0185-305)

3.3 Internal lightning protection

Internal lightning protection refers to measures which counteract the effects of lightning strikes and surges that may arise despite the external lightning protection. The following events can cause these disturbances:

- ▶ A lightning strike some distance away, which subsequently diffuses through the power network.
- ▶ Discharges in the atmosphere that are not accompanied by visible lightning.

There are 2 ways in which these surges can get into a building and then spread: Via the connection to the public power supply or via cable entry points, for example antennas fixed to the outside of the building.

The following is a description of how to protect the system from the antenna side. Only a lightning protection professional is authorized to plan and implement the protection for equipment connected to the power supply from surges emanating from the public power supply.

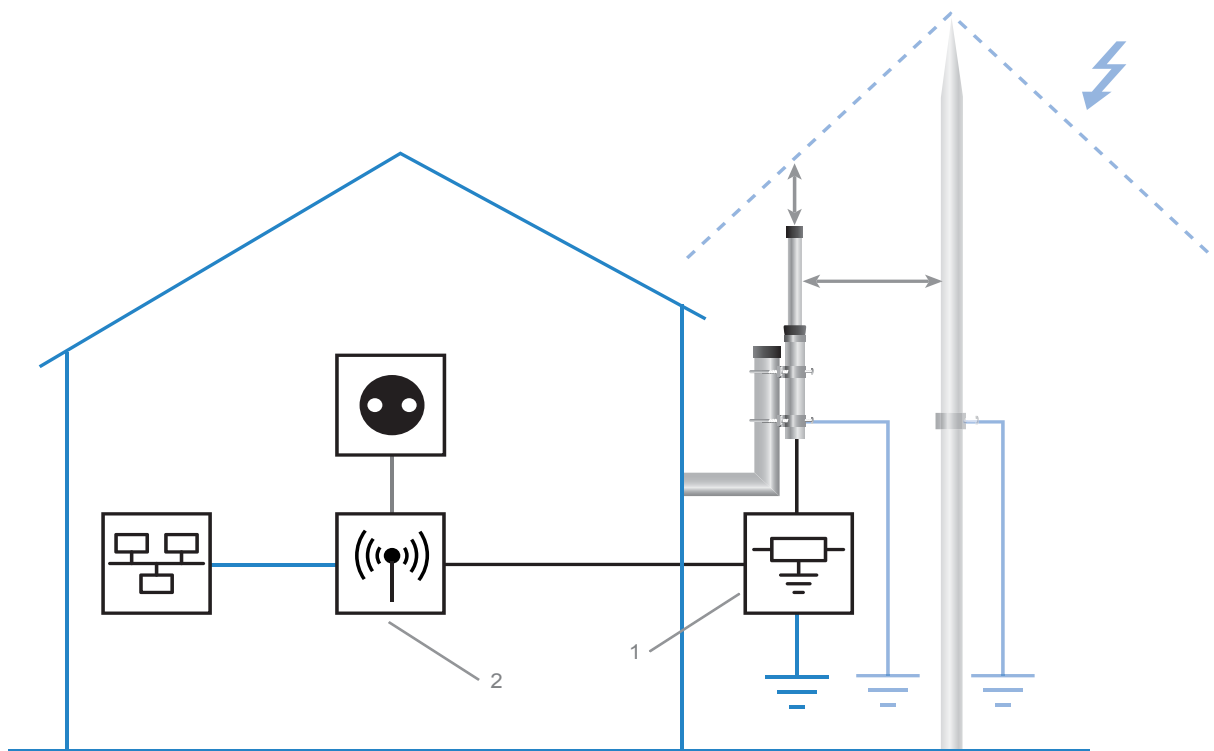

Figure 19: BAT-ANT-Protector m-f between BAT Access Point and antenna
1 BAT-ANT-Protector m-f
2 BAT Access Point

The central component for internal lightning protection is the surge protection device BAT-ANT-Protector m-f. The use of the BAT-ANT-Protector m-f is essential under all circumstances – despite external lightning protection measures, partial discharges can still give rise to surges that can damage sensitive radio modules.

Make sure that the lightning protection professional always mounts the BAT-ANT-Protector m-f between the Access Point and the antenna, preferably as near as possible to the Access Point. The BAT-ANT-Protector m-f should be positioned behind the endangered portion of the antenna cable in a location where it can be grounded. If the Access Point is installed outside, the lightning protection professional connects its grounding and that of the BAT-ANT-Protector m-f with the conductor of the antenna, for example via the clamps on the mounting of the antenna.

In addition to this, the lightning protection professional can use a LAN surge protection device to reduce possible surges in the Ethernet cable or PoE cable.

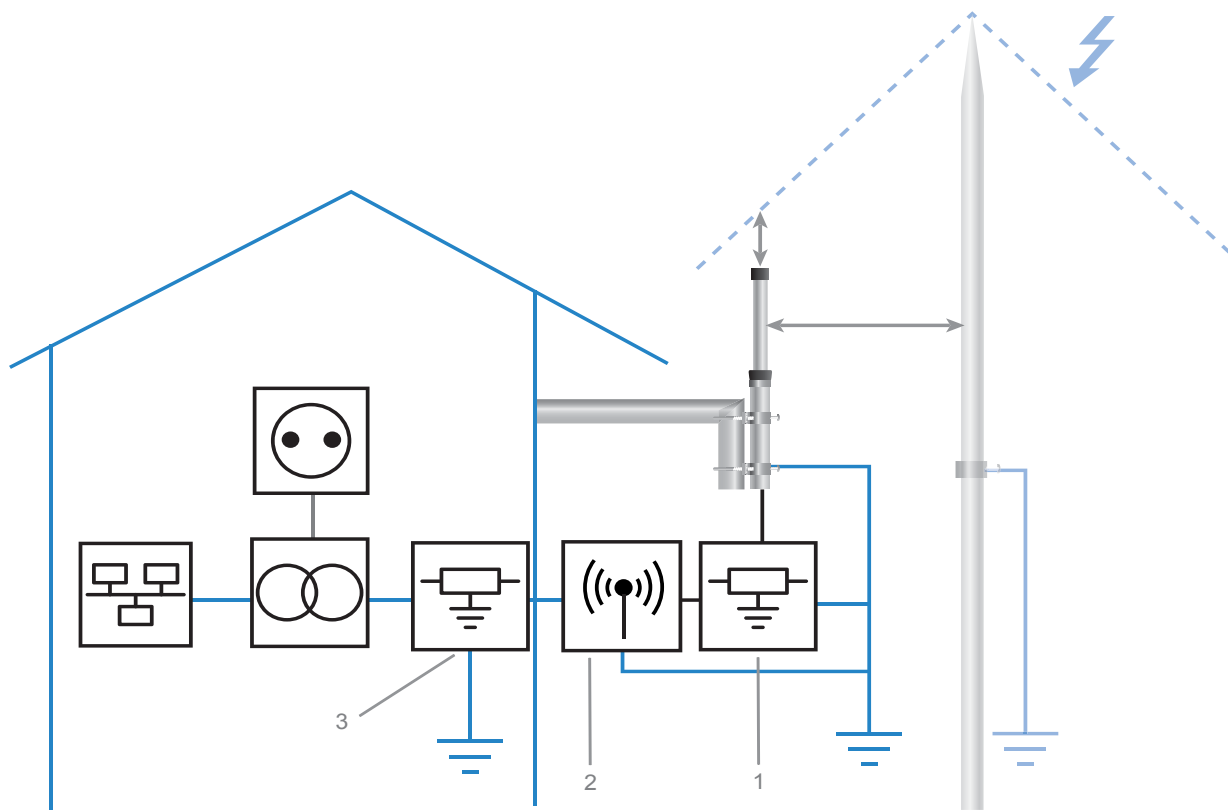

Figure 20: Lightning protection for outdoor installations

- 1 BAT-ANT-Protector m-f
- 2 BAT Access Point
- 3 BAT-LAN-Protector IP68

3.4 Selecting the components for lightning protection and surge protection

3.4.1 Classification of surge protective devices

So-called surge protection devices (SPDs) are used to protect electrical and electronic devices in buildings. These are divided into various categories depending on the purpose of their application:

- ▶ Buildings: The greatest danger from the effects of lightning strikes is the transmission of high lightning currents via the cables that from exposed objects such as the antennas directly into the building. Additionally to lightning currents, surges can enter the building via these cables. Make sure that the lightning protection professional that performs the work installs a lightning arrester (Type 1) and a surge protection device such as the BAT-ANT-Protector m-f) to the relevant cables directly where they enter the building.
- ▶ Power supply: Surges can also find their way into the building via the power supply and can thereby endanger electronic equipment. Type 2 surge protection devices protect from these surges by lowering the surge peaks to a sufficiently low level. The lightning protection professional uses these Type 2 surge protection devices, for example, in the control cabinet.
- ▶ End devices: The last stage in the surge protection chain is the direct protection of the end devices. Make sure that the lightning protection professional uses Type 3 surge protection devices for this, for example in the form of power socket adapters. These surge protection devices work by lowering any surges that may occur to a level that is not dangerous for highly sensitive equipment.

The risk assessment and the resulting design of a suitable lightning protection system always depends on local conditions (for example the frequency with which lightning strikes are to be expected). Make sure that the risk assessment is carried out by a lightning protection professional.

Note: Make sure that in addition to implementing lightning protection for WLAN systems, the lightning protection professional plans and installs protection for the building itself and for other equipment separately.

3.4.2 External lightning protection

■ Lightning rod

- ▶ When? Required if the antenna or any other element of the WLAN system is mounted in an exposed position.
- ▶ Where? Calculate the safety clearance to the antenna or other conductive elements of the WLAN system according to IEC 62305 / DIN EN 62305 (VDE 0185-305), taking into account the local conditions and the selected protection class.
- ▶ Conductor? Grounding via potential equalization line (PEL, 16 mm² Cu) always required.

■ Antenna potential equalization

- ▶ Installation of the antenna in a protected position (without lightning rod): Grounding via potential equalization line (PEL, 16 mm² Cu).
- ▶ Installation of the antenna without lightning rod: Grounding via separate potential equalization line (PEL, 16 mm² Cu). Separation distance according to IEC 62305 / DIN EN 62305 (VDE 0185-305).

3.4.3 Internal lightning protection

■ **Surge protection device BAT-ANT-Protector m-f (Order number 943 903-373)**

- ▶ When? Always absolutely necessary. Also protects against partial discharges that can damage sensitive radio modules when there is no direct lightning strike.
- ▶ Where? Position as near as possible to antenna connector on the Access Point.
- ▶ Conductor? Potential equalization via the building's grounding system using a PE line (protective earth – 1.5 mm² Cu).

Note: Hirschmann will only fulfill its warranty obligations when you operate WLAN devices in combination with a BAT-ANT-Protector m-f surge protection device. This lightning protection device is explicitly designed for the radio modules in BAT devices. Hirschmann fulfills no warranty obligations if you use different surge protection devices.

■ **LAN surge protection device BAT-LAN-Protector IP68 (Order number 943 903-374)**

- ▶ When? Depends on the individual risk and protection requirements of the devices and cabling in the LAN, e.g. the outdoor equipment with integrated antennas.
- ▶ Where? As near as possible to the Access Point's ETH connector.
- ▶ Conductor? Potential equalization via the building's grounding system using a PE line (protective earth – 1.5 mm² Cu).

3.4.4 Example applications

Depending on where the Access Point, antennas and lightning rods are positioned there are numerous combinations of equipment for lightning protection and surge protection. The following illustrations show some sample scenarios that are frequently found in practice.

■ Scenario 1:

Antenna in a protected position

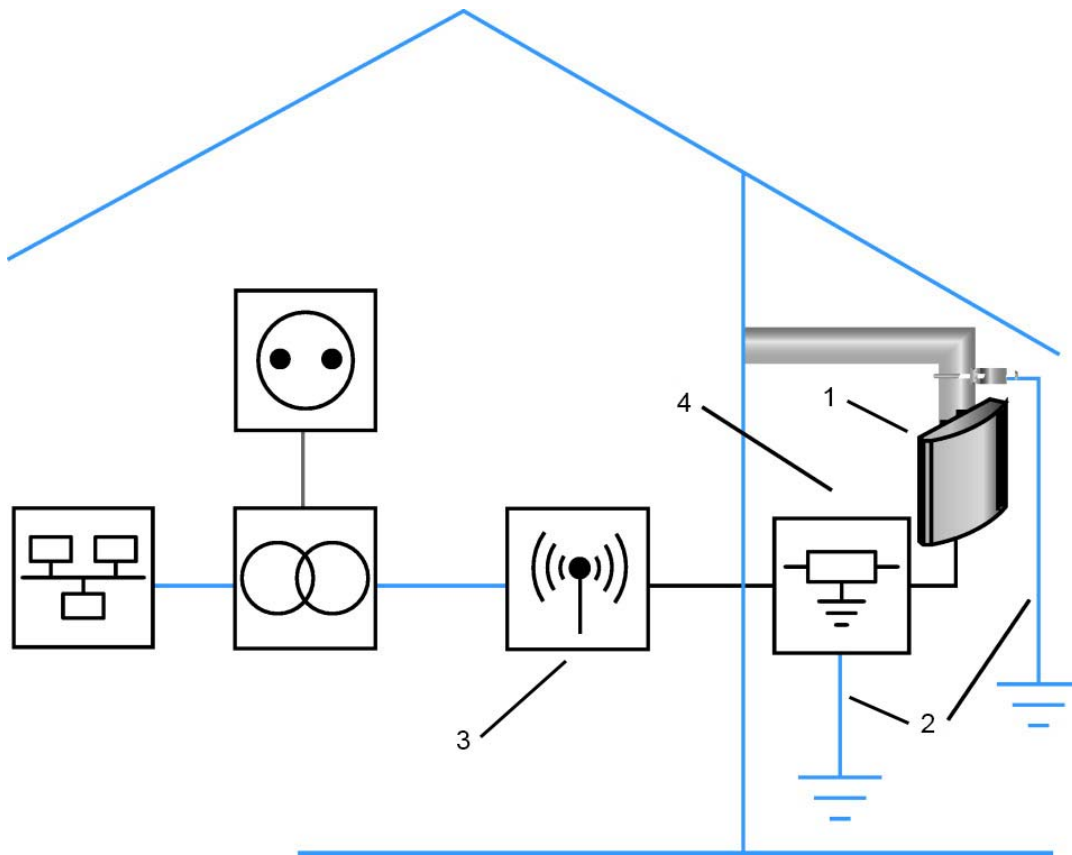

Figure 21: Scenario 1: Antenna in a protected position

1 Antenna

2 Potential equalization line (PEL), 16 mm² Cu

3 BAT Access Point

4 BAT-ANT-Protector m-f

The basic situation shows an application where the antenna is mounted in a protected place – there is therefore no danger of a direct lightning strike.

- ▶ It is sufficient for lightning protection to have an adequately dimensioned potential equalization line for the antenna.
- ▶ Make sure to protect The Access Point with a BAT-ANT-Protector m-f for internal protection in any case.

■ **Scenario 2:**

Antenna in an exposed position, safety clearance to lightning rod observed

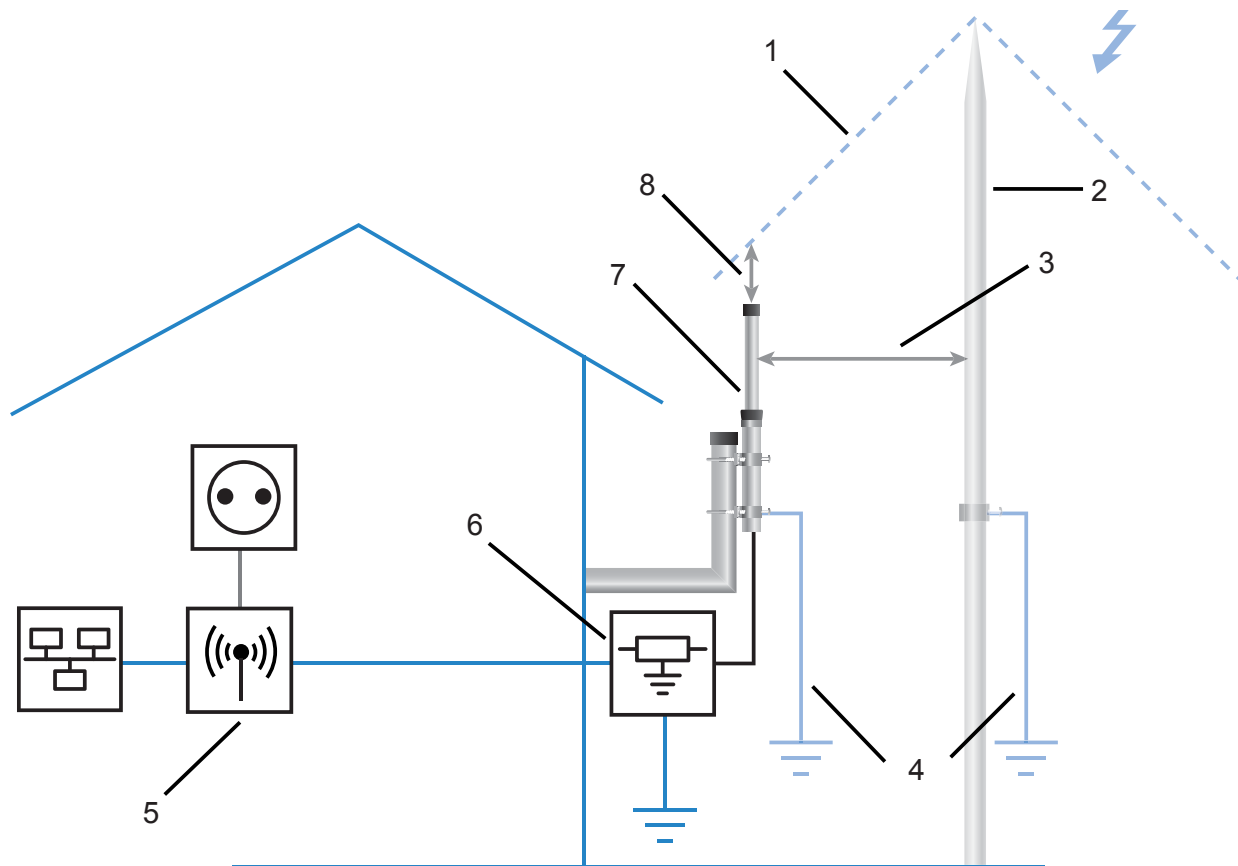

Figure 22: Scenario 2: Antenna in an exposed position

- 1 Area protected by insulated lightning protection system (LPS)
- 2 Lightning rod
- 3 Safety clearance according to IEC 62305 / DIN EN 62305 (VDE 0185-305)
- 4 Potential equalization line (PEL), 16 mm² Cu
- 5 BAT Access Point
- 6 BAT-ANT-Protector m-f
- 7 Antenna
- 8 Separation distance according to IEC 62305 / DIN EN 62305 (VDE 0185-305)

In this example the antenna is mounted in such a way that a direct lightning strike is possible. As a protective measure, the lightning protection professional installed a lightning rod with a sufficient safety clearance according to IEC 62305 / DIN EN 62305 (VDE 0185-305).

- ▶ As external lightning protection both the antenna and the lightning rod are separately grounded with their own potential equalization lines.
- ▶ There are no other aspects to be considered for internal lightning protection.

■ **Scenario 3:**
BAT Access Point installed outdoors

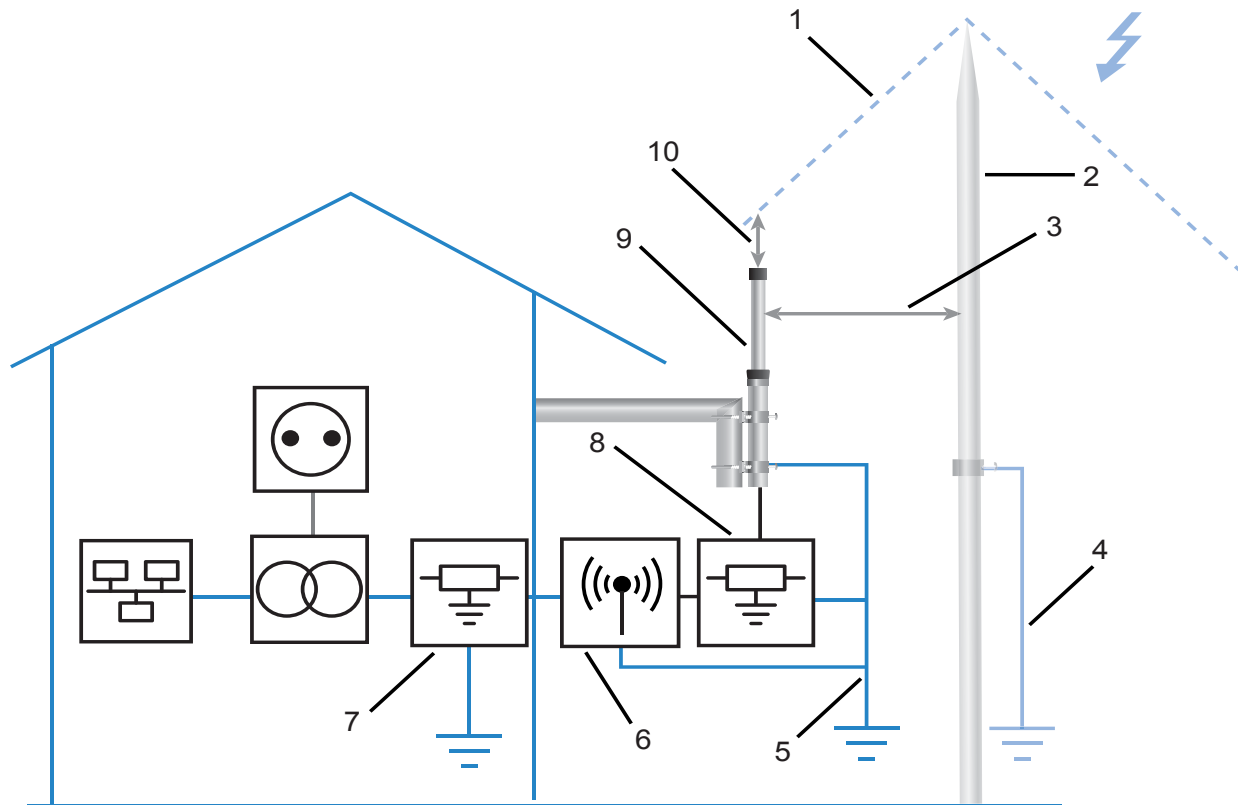

Figure 23: Scenario 3: BAT Access Point installed outdoors

- 1 Area protected by insulated lightning protection system (LPS)
- 2 Lightning rod
- 3 Safety clearance according to IEC 62305 / DIN EN 62305 (VDE 0185-305)
- 4 Potential equalization line (PEL), 16 mm² Cu
- 5 Potential equalization line (PEL), 16 mm² Cu
- 6 BAT Access Point
- 7 BAT-LAN-Protector IP68
- 8 BAT-ANT-Protector m-f
- 9 Antenna
- 10 Separation distance according to IEC 62305 / DIN EN 62305 (VDE 0185-305)

In this case, the lightning protection professional installs the BAT-ANT-Protector m-f surge protection device directly between Access Point and antenna and grounds the BAT-ANT-Protector m-f for example via the potential equalization line of the antenna.

If you operate any Access Point installed outdoors with the supplied rod antenna instead of an external antenna, you cannot employ the lightning protection device BAT-ANT-Protector m-f due to the connector shape. In this case it is imperative to employ a lightning rod!

- ▶ If the Access Point is installed outdoors, the lightning protection professional connects its grounding and that of the BAT-ANT-Protector m-f with the conductor of the antenna, for example via the clamps on the mounting of the antenna.
- ▶ The lightning protection professional can fix the BAT-ANT-Protector m-f directly to the antenna socket with the aid of a short adapter (gender changer), depending on the model of the Access Point.

4 Installation

4.1 Mounting Notes



DANGER

LIGHTNING STRIKE AND SURGE

The installation and mounting of the Access Points and antennas may only be carried out by a lightning protection professional. The lightning protection professional must be familiar with the local conditions and any country-specific safety regulations.

Also follow the instructions in chapter [“Lightning protection and surge protection”](#) and make sure that the grounding system meets the requirements.

Failure to follow these instructions will result in death, serious injury, or equipment damage.

Observe the following instructions for protection against accidents:

- Do not mount Access Points or antennas in weather conditions when lightning may be expected.
- Similarly, refrain from connecting or disconnecting cables during weather of this type.
The components of a WLAN can be subject to variations in electrical charge even in normal weather conditions. Perform all work with the utmost care.
- Make sure that the Access Points, antennas and mounting equipment such as masts intended for outdoor use are properly grounded.
- Carry out work of this type with a minimum of 2 people. This helps ensure that help can be quicker to hand if an accident occurs despite all safety precautions.
- Only use ladders with the appropriate insulation.
- Only work in dry weather without wind. If necessary, use a harness or similar for securing.
- Wear suitable working clothing, such as close-fitting clothing and safety shoes with non-slip soles.

- If you should drop components of the antennas or mountings, let them fall without attempting to catch them. Falling antennas, masts or cables may come into contact with live contacts and cause electric shock.
- The mounting location should be easily accessible in the interests of future maintenance work or for checking cable connections.
- Before starting with mounting, check that you have all the necessary tools and accessory parts available. Similarly, ensure that any openings required for the entry of the coaxial or Ethernet cable into the building are already available.

4.2 Mounting the Access Points



DANGER

LIGHTNING STRIKE AND SURGE

The installation and mounting of the Access Points and antennas may only be carried out by a lightning protection professional. The lightning protection professional must be familiar with the local conditions and any country-specific safety regulations.

Also follow the instructions in chapter [“Lightning protection and surge protection”](#) and make sure that the grounding system meets the requirements.

Failure to follow these instructions will result in death, serious injury, or equipment damage.

The method for mounting the Access Points depends on the model's design. This section presents the various mounting types, illustrated by examples. Please refer to the documentation for the relevant Access Points for more specific instructions.

Note: Only a lightning rod with a safety clearance according to IEC 62305 / DIN EN 62305 (VDE 0185-305) can protect the Access Points outdoors from direct lightning strikes!

- Ground the Access Points outdoors via a sufficiently dimensioned potential equalization line (PEL) with a cross-section of at least 16 mm² CU. Use a surge protection device for the protection of sensitive radio modules.

4.2.1 Selecting the location for mounting

Before mounting any antennas, a suitable location for mounting antennas should meet the following conditions:

- ▶ Avoid covering the Access Points and antennas to help ensure interference-free sending and receiving and to prevent overheating.
- ▶ Choose a location that is as close as possible to the necessary connections, such as LAN interfaces or power sockets.
- ▶ Position the Access Points as close as possible to the antennas. The length of the coaxial cable between Access Point and antenna has a considerable influence on the attenuation in the WLAN system as a whole, thus influencing such factors as the available range and data rates.
- ▶ Observe the maximum distance between Access Points and PoE Injectors. For example, some Access Points have an increased power requirement that can exclusively be supplied over a specific length of Ethernet cable. You can find detailed advice in the documentation for the Access Points or the PoE Injector.
- ▶ Locations where you mount components outdoors have to be as close as possible to the point where the coaxial or Ethernet cables enter the building. Excessive stretches of outdoor cabling are exposed to increased atmospheric effects.
- ▶ Avoid locations that are very dusty.
- ▶ Outdoors, avoid locations that are close to exposed metallic conductors, such as gutters.

4.2.2 Installing the device onto or on a flat surface

You have the option of attaching the device with suitable hardware to a vertical flat surface.

- ▶ The diameter of the mounting hardware is maximum 0.20 in (5 mm).
- ▶ The head diameter is maximum 0.47 in (12 mm).
- ▶ The diameter of a flat washer used is maximum 0.48 in (12 mm).

Proceed as follows:

- Prepare the assembly at the installation site.
- Install the device with suitable fastening components.
- Seal all unused connections and ports with protection screws.

4.2.3 Installing the device on a pole

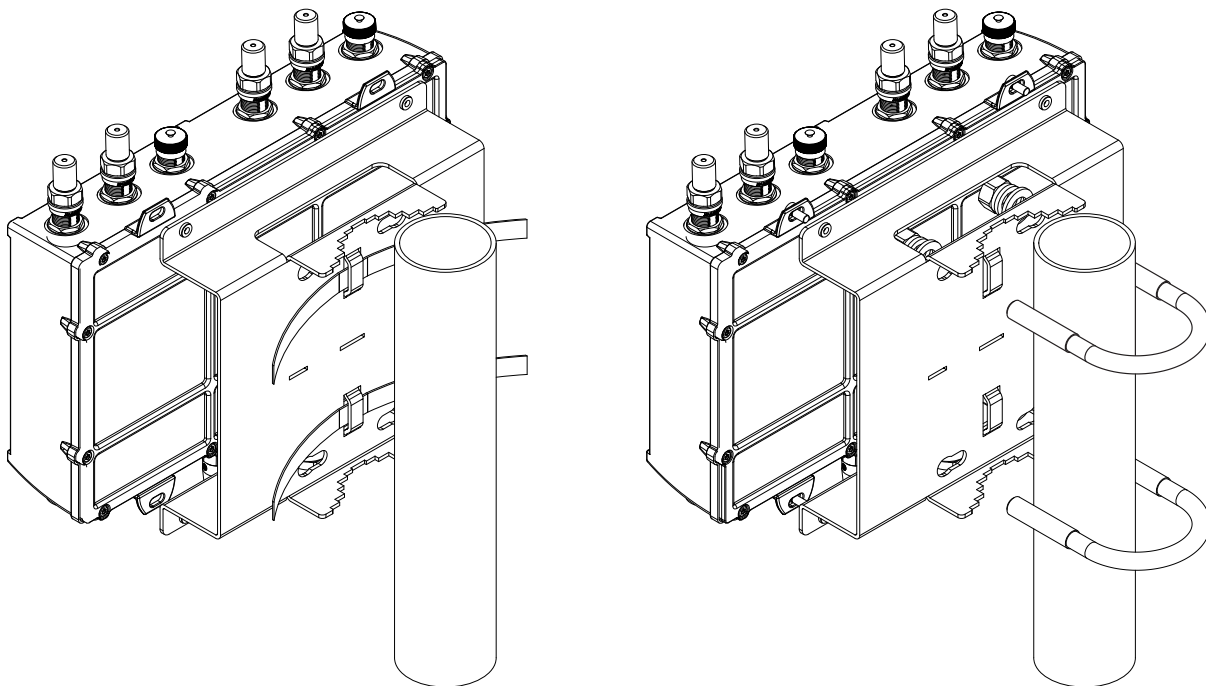

You have the option of installing the device on a pole, pipe, strut, or on a similarly stable construction using a pole mounting set.

The pole mounting set you obtain as an accessory.

- ▶ The clamping diameter of the mast clamp is maximum 2.56 in (65 mm).
- ▶ Tightening straps, available from a specialist dealer, enable you to clamp a larger mast diameter.
 - ▶ maximum width of the tightening strap: 0.63 in (16 mm)
 - ▶ maximum thickness of the tightening strap: 0.05 in (1.3 mm)

4.3 Mounting antennas



DANGER

LIGHTNING STRIKE AND SURGE

The installation and mounting of the Access Points and antennas may only be carried out by a lightning protection professional. The lightning protection professional must be familiar with the local conditions and any country-specific safety regulations.

Also follow the instructions in chapter [“Lightning protection and surge protection”](#) and make sure that the grounding system meets the requirements.

Failure to follow these instructions will result in death, serious injury, or equipment damage.

The mounting of the antennas depends on the design of the respective models. This section presents the various mounting types, illustrated by examples. Refer to the documentation of the relevant antenna for more specific instructions.

Note: Make sure that a lightning rod with a safety clearance according to IEC 62305 / DIN EN 62305 (VDE 0185-305) is fixed to antennas mounted outdoors in an exposed position with the risk of direct lightning strike!

- Ground the antennas mounted outdoors with a sufficiently dimensioned potential equalization line (PEL) with a cross-section of at least 16 mm² CU. Use a surge protection device for the protection of sensitive radio modules.

4.3.1 Selecting the location for mounting

Before mounting any antennas, choose a suitable location for mounting antennas that meet the following conditions:

- ▶ Mount the antennas in a place offering a good line of sight for transmitting data to mobile WLAN clients or remote point-to-point stations.
- ▶ Mount antennas as close as possible to the Access Points. The length of the coaxial cable between Access Point and antenna has a considerable influence on the attenuation in the WLAN system as a whole, thus influencing such factors as the available range and data rates.
- ▶ Locations where you mount components outdoors have to be as close as possible to the point where the coaxial or Ethernet cables enter the building. Excessive stretches of outdoor cabling are exposed to increased atmospheric effects.
- ▶ Outdoors, avoid locations that are close to exposed metallic conductors, such as gutters.

4.3.2 Flat surface mounting

Permanent mounting can take place directly on a flat surface or with the adjustable swivel fixture.

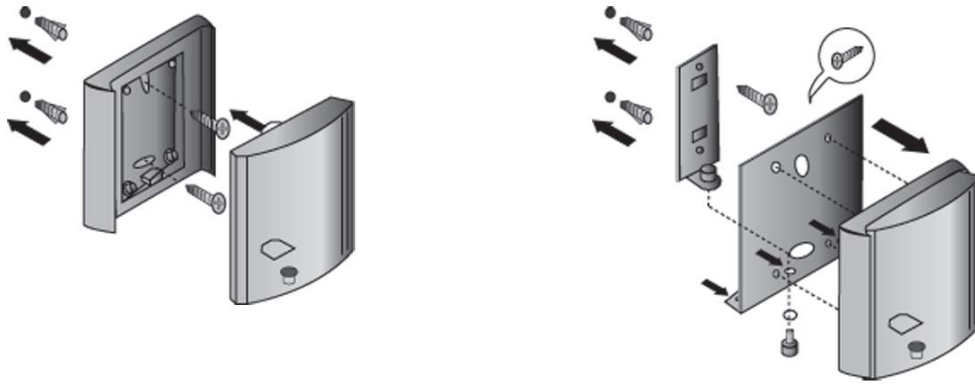

Figure 24: Flat surface mounting

4.3.3 Pole mounting

Alternatively mount the antenna directly on a pole or similar structure, giving the antenna a high degree of exposure.

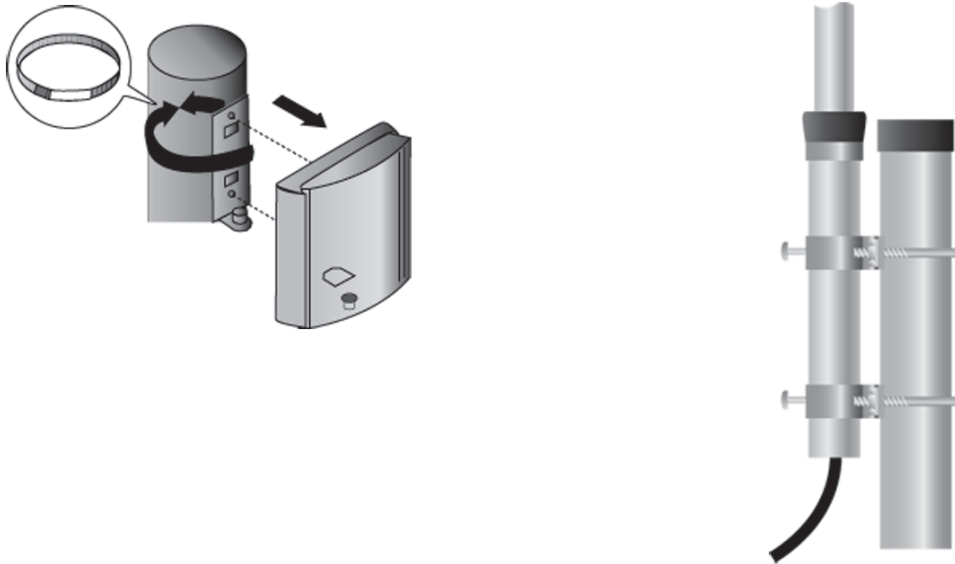

Figure 25: Pole mounting

4.4 Mounting the lightning rods



DANGER

LIGHTNING STRIKE AND SURGE

The dimensioning, installation and grounding of the lightning rods may only be carried out by a lightning protection professional. The lightning protection professional must be familiar with the local conditions and any country-specific safety regulations.

Also follow the instructions in chapter [“Lightning protection and surge protection”](#) and make sure that the grounding system meets the requirements.

Failure to follow these instructions will result in death, serious injury, or equipment damage.

Lightning rods create a protected area that is designed to protect the components in a WLAN system such as antennas or Access Points from a direct lightning strike.

Observe the following aspects for the selection of the mounting location:

- ▶ Dimensioning of the lightning rod
- ▶ Vertical and horizontal distance from the components at risk
- ▶ Grounding of the lightning rod

4.4.1 Dimensioning of the lightning rod

The task of the lightning rod is to be able to conduct the complete charge of a lightning strike. For this reason it is important for you to select lightning rods made from highly conductive metals, for example copper alloys or steel. It is important for you to select lightning rods with a cross-section that allows the conduction of the lightning charge without damaging the lightning rod. In general, a lightning rod with a diameter of 10 mm to 16 mm meets this requirement.

4.4.2 Distance to the components at risk

To dimension the lightning rods for a sufficiently large protected area, the lightning protection professional determines the safety clearance of the lightning rod from the equipment to be protected (for example an antenna) and the height of the lightning rod.

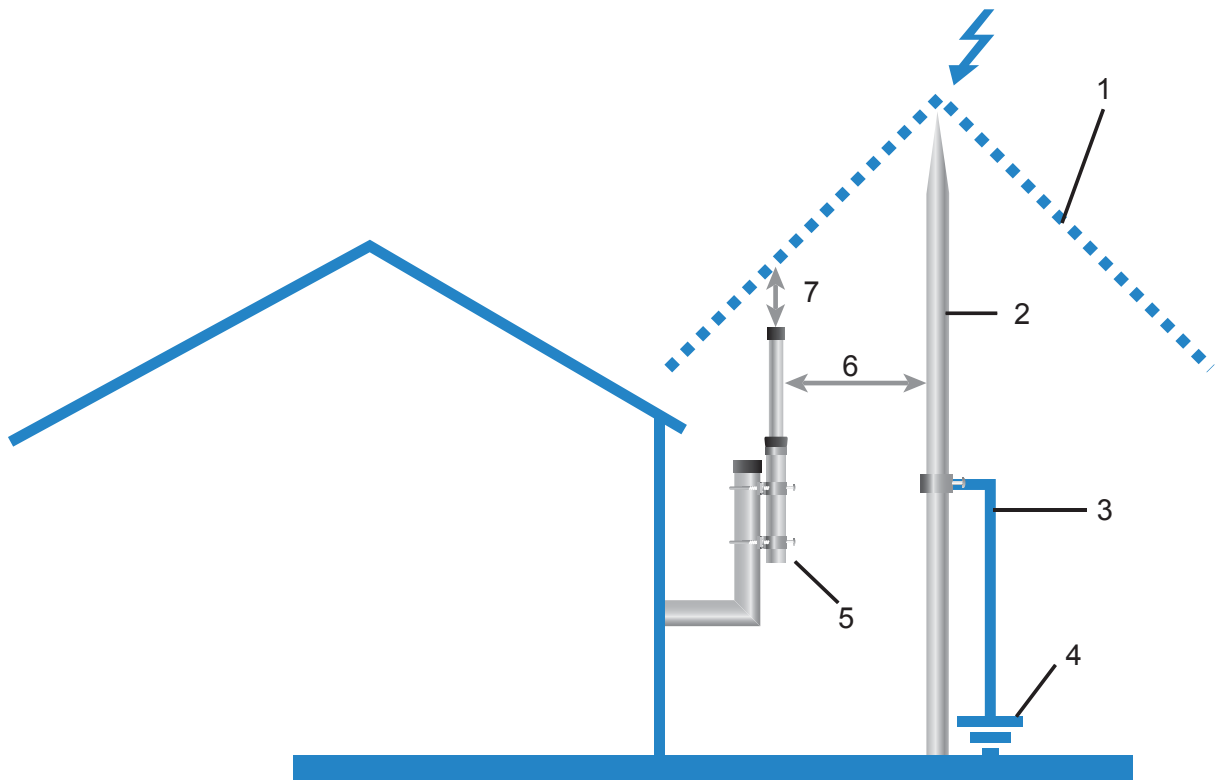

Figure 26: External lightning protection

- 1 Area protected by insulated lightning protection system (LPS)
- 2 Lightning rod
- 3 Conductor
- 4 Grounding
- 5 Antenna
- 6 Safety clearance according to IEC 62305 / DIN EN 62305 (VDE 0185-305)
- 7 Separation distance according to IEC 62305 / DIN EN 62305 (VDE 0185-305)

- ▶ Safety clearance of the lightning rod from the antenna: Positioning the lightning rod a sufficient distance away from the antenna prevents the conducted lightning charge from flashing over to the antenna or other conductive components. The lightning protection professional can exactly calculate the safety clearance on the basis of several factors.
- ▶ Lightning rod height: Make sure that the lightning rod is high enough so that the equipment that is to be protected, such as antennas, is within the protected area.

Note: The safety clearance between lightning rod and antenna has a direct influence on the grounding required by the components. Observe the instructions about grounding the lightning rod and grounding the antennas and Access Points.

4.4.3 Lightning charge conduction (grounding)

- Ground the lightning rods only via a separate, sufficiently dimensioned potential equalization line (PEL) with a cross-section of at least 16 mm² CU. Select the shortest path for the connection to the grounding system.

Note: The lightning rod and antenna require separate grounding if you mount the lightning rod with the antenna on the same mast. In this case, sufficiently insulate the lightning rod from the mast.

A Appendix

A.1 Antenna characteristics

Refer to the Antenna Guide for further information.
The manual is available for download on the Internet: [https://
www.doc.hirschmann.com](https://www.doc.hirschmann.com)

A.2 Troubleshooting

If your outdoor WLAN bridge produces throughput rates that are significantly lower than expected, consider the following possibilities:

■ **Antenna polarization**

Some antennas for WLAN transmission rely on certain directions of polarization of the electromagnetic waves. For point-to-point links, align the direction of polarization of the antennas at each end of the connection precisely in the same direction. If the directions of polarization are opposite, the data throughput can be reduced. For this reason check the correct alignment—both in direction and polarity—to provide optimal data throughput when installing outdoor WLAN systems.

■ **Weathering**

When mounted correctly, the Access Points and antennas of outdoor WLAN systems are protected from the effects of rainfall, humidity and other environmental influences. If the seals on the housing or cable connections are mounted deficiently, or if they become damaged, water or water vapor may enter the device, with adverse effects for the electronic components. If you experience sudden variations in data throughput over the WLAN bridge, check the cabling and seals for damage.

■ **Free line of sight and Fresnel zones**

Maximum performance requires a line of sight on one hand and a minimum separation between the line of sight and the ground or other obstructions on the other hand. Use the BAT Antenna Calculator tool that you can download from our Web site at www.hirschmann.com to calculate the necessary mast heights for obstruction-free Fresnel zones.

■ Antenna cable

To improve performance, use a short length of antenna cable with a low attenuation value.

■ DFS channel selection

Check if the Access Point detects vacant channels (see the HiLCOS menu tree under Status/WLAN/Channel scan results).

■ 40 MHz mode

To improve performance of 802.11n access points, provide a neighboring channel for channel bundling. The HiLCOS menu tree informs you whether an "extension channel" is available under "Status/WLAN/Radios."

■ Distance settings

For longer-range wireless links to function properly, specify the range between the two antennas (rounded up to the nearest kilometer). This allows you to adjust the system's internal timing values accordingly.

■ General diagnosis

You can inspect packet transmission statistics under Status/WLAN/Packets and status/WLAN/Errors. High values may indicate an environment with strong interference.

Check the following values for an indication of the signal/noise ratio and for detecting rogue WiFi Devices: Status/WLAN/Channel scan results, Status/WLAN/WLAN parameters and Status/WLAN/Competing networks.

If error rates are 100%, the most probable cause is a value for distance that is too low.

B Further support

Technical questions

For technical questions, please contact any Hirschmann dealer in your area or Hirschmann directly.

You find the addresses of our partners on the Internet at <http://www.hirschmann.com>.

A list of local telephone numbers and email addresses for technical support directly from Hirschmann is available at <https://hirschmann-support.belden.com>.

This site also includes a free of charge knowledge base and a software download section.

Hirschmann Competence Center

The Hirschmann Competence Center is ahead of its competitors on three counts with its complete range of innovative services:

- ▶ Consulting incorporates comprehensive technical advice, from system evaluation through network planning to project planning.
- ▶ Training offers you an introduction to the basics, product briefing and user training with certification.
You find the training courses on technology and products currently available at <http://www.hicomcenter.com>.
- ▶ Support ranges from the first installation through the standby service to maintenance concepts.

With the Hirschmann Competence Center, you decided against making any compromises. Our client-customized package leaves you free to choose the service components you want to use.

Internet:

<http://www.hicomcenter.com>



HIRSCHMANN

A **BELDEN** BRAND