

ECX SPLICE CASSETTE INSTALLATION GUIDE



ES: Visite nuestra pagina web www.belden.com para obtener el guía de instalación en español.
FR: Veuillez visiter notre site web au www.belden.com pour obtenir le guide d'installation en français.

Carton contents

1. Housing (1X)
2. Cover (1X)
3. Universal splice holder (optional)
4. Cable tie (not shown)

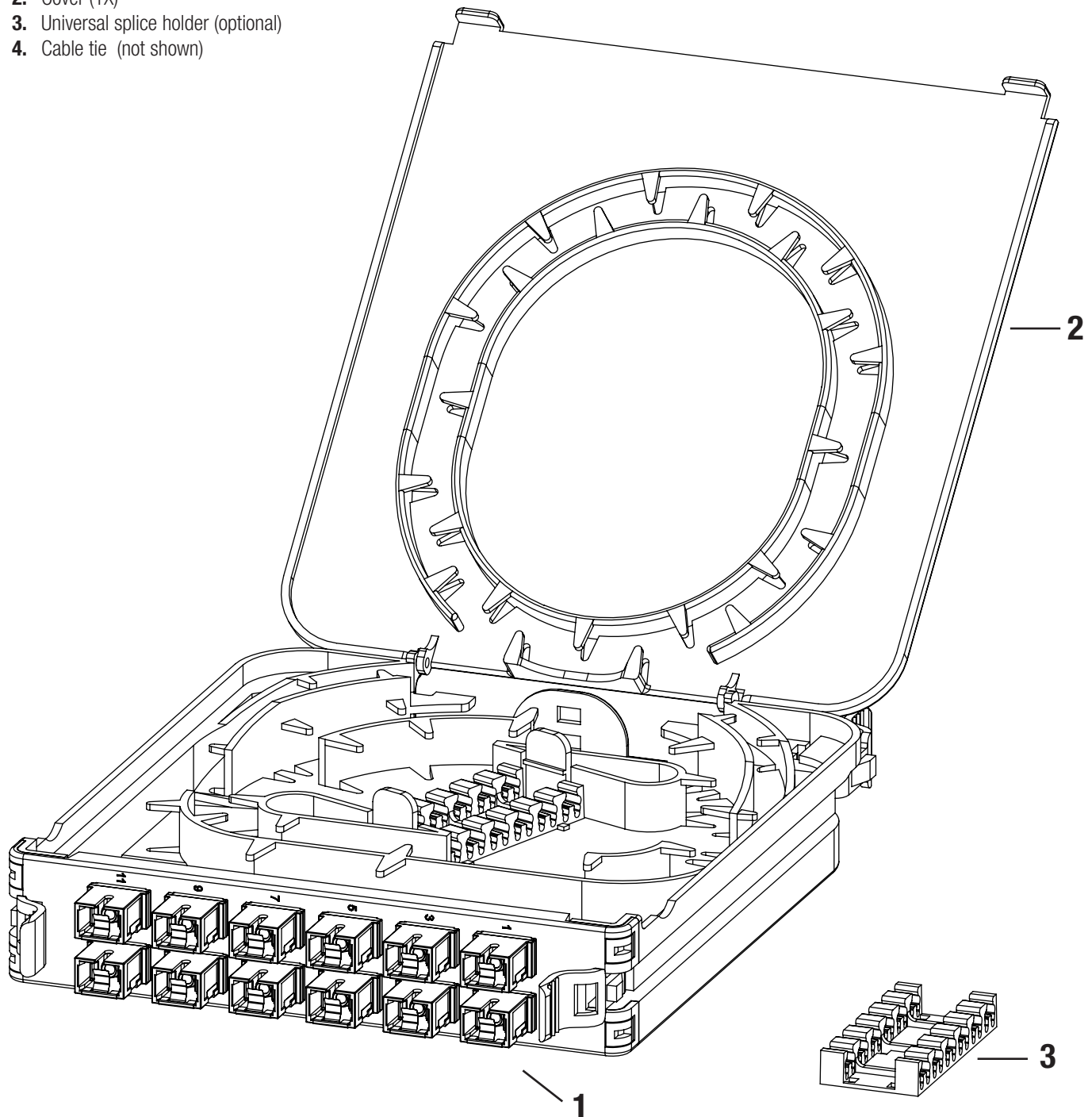

Routing fiber splice cassette

The following instructions describe fiber routing and splicing inside the splice cassette. Please take note that the splice cassette is adapted for splicing and managing 900 μ m (tight buffer) and 250 μ m optical fiber.

- 1 Cable preparation: Leave 53in approx. of sub-unit and another 34in approx. of 900 μ m.
Pigtail preparation: Leave 63in approx. of 900 μ m fiber.

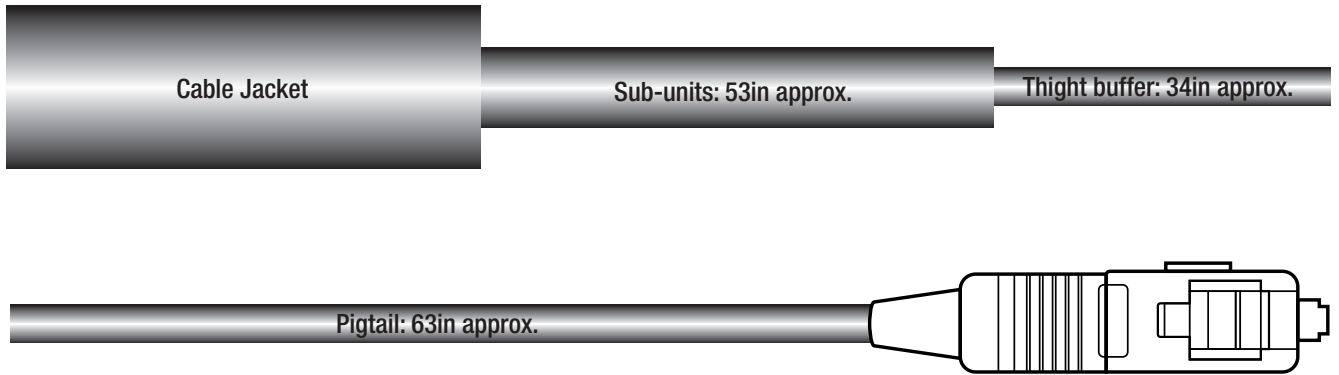

- 2 Open the splice cassette.
Remove the cover.

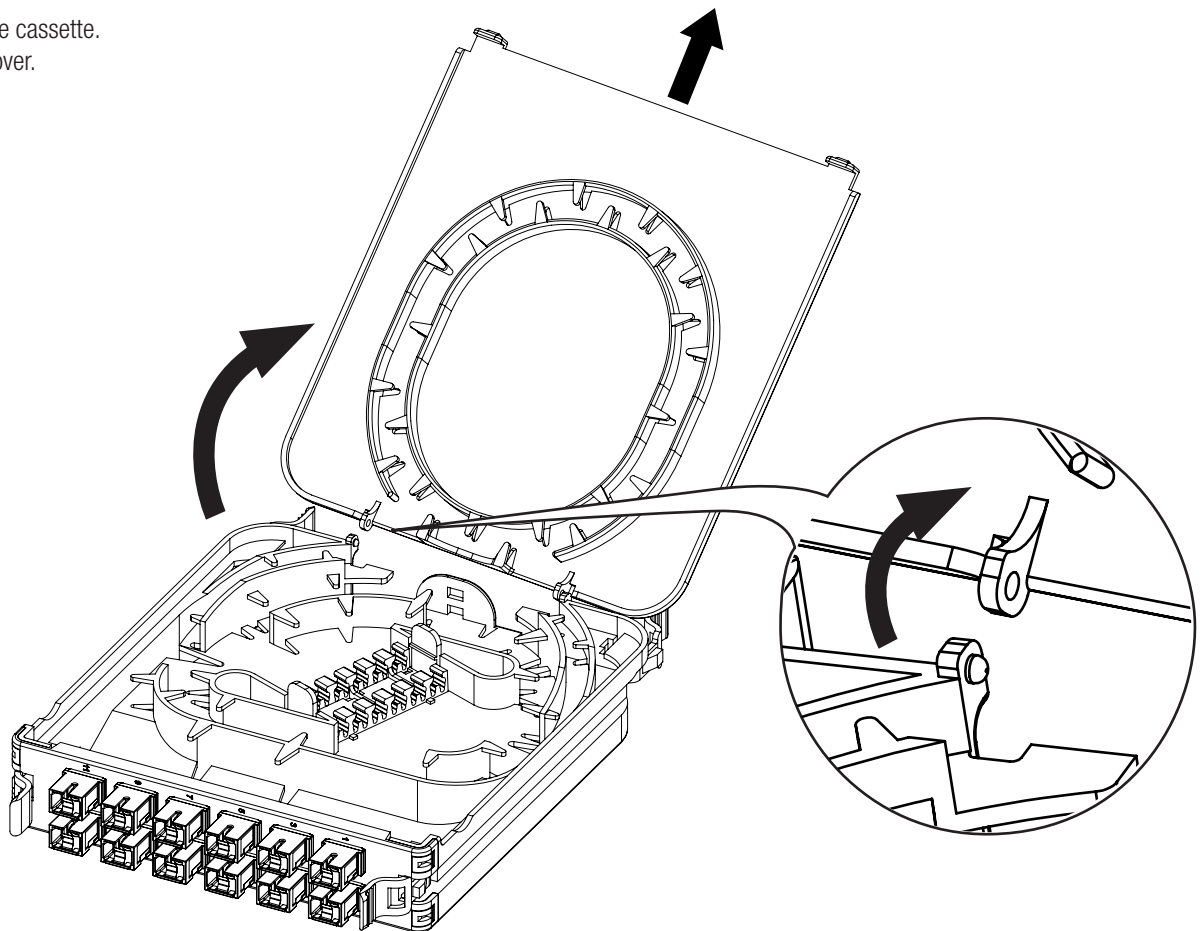

3 Secure the end of the sub-unit with the provided cable tie.

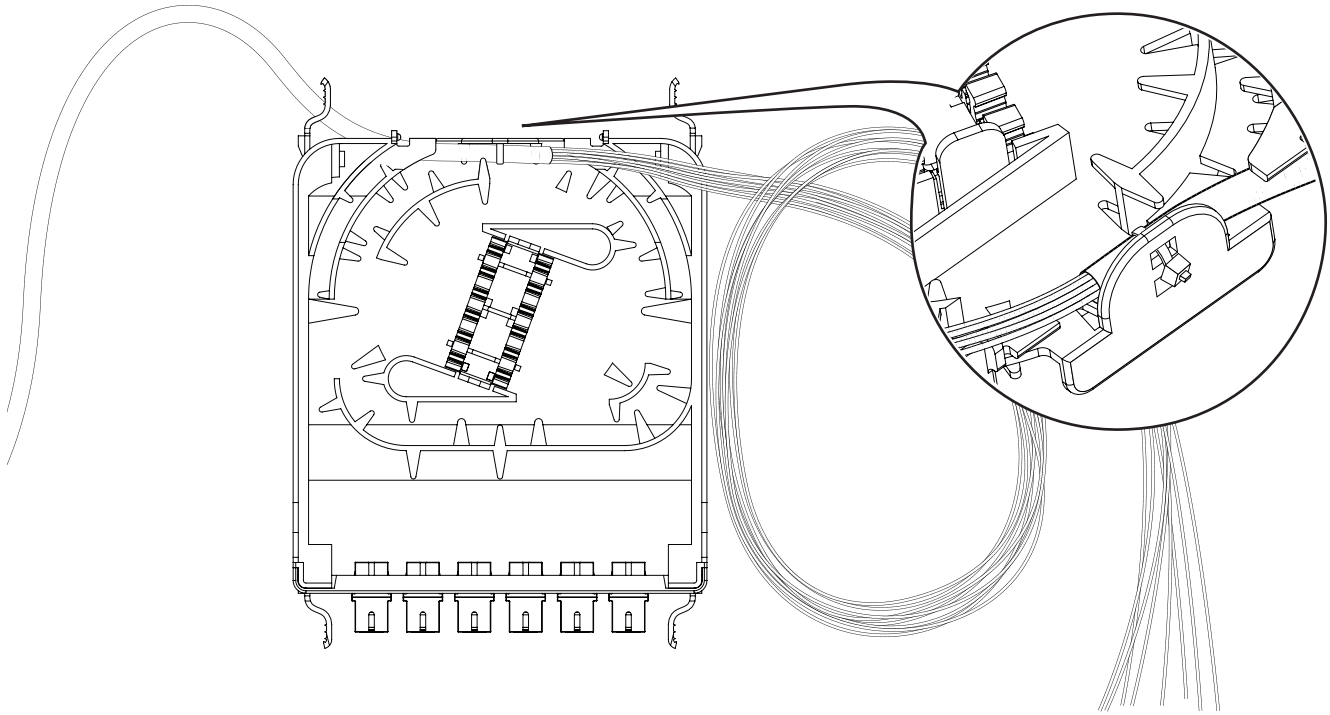

4 Loop the fiber twice (2) as shown.
Make sure fiber is well positioned under routing tabs.

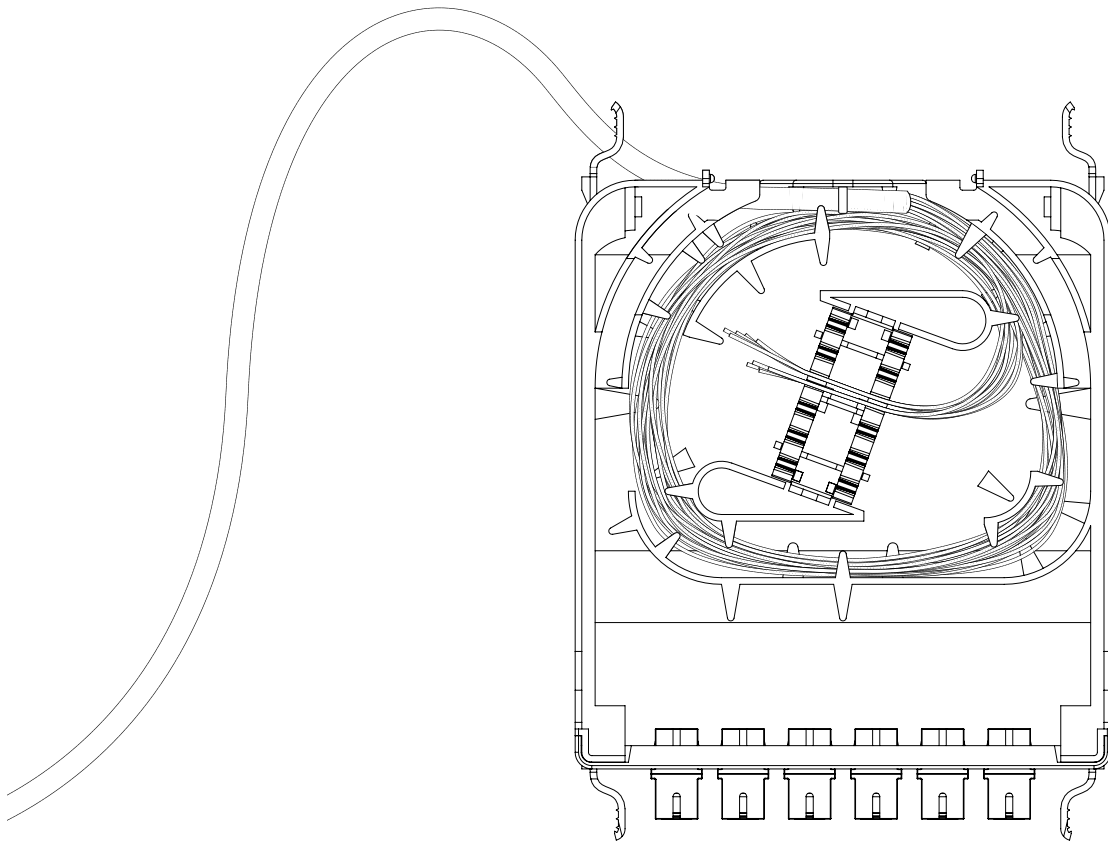

5 Reinstall and close the cover.

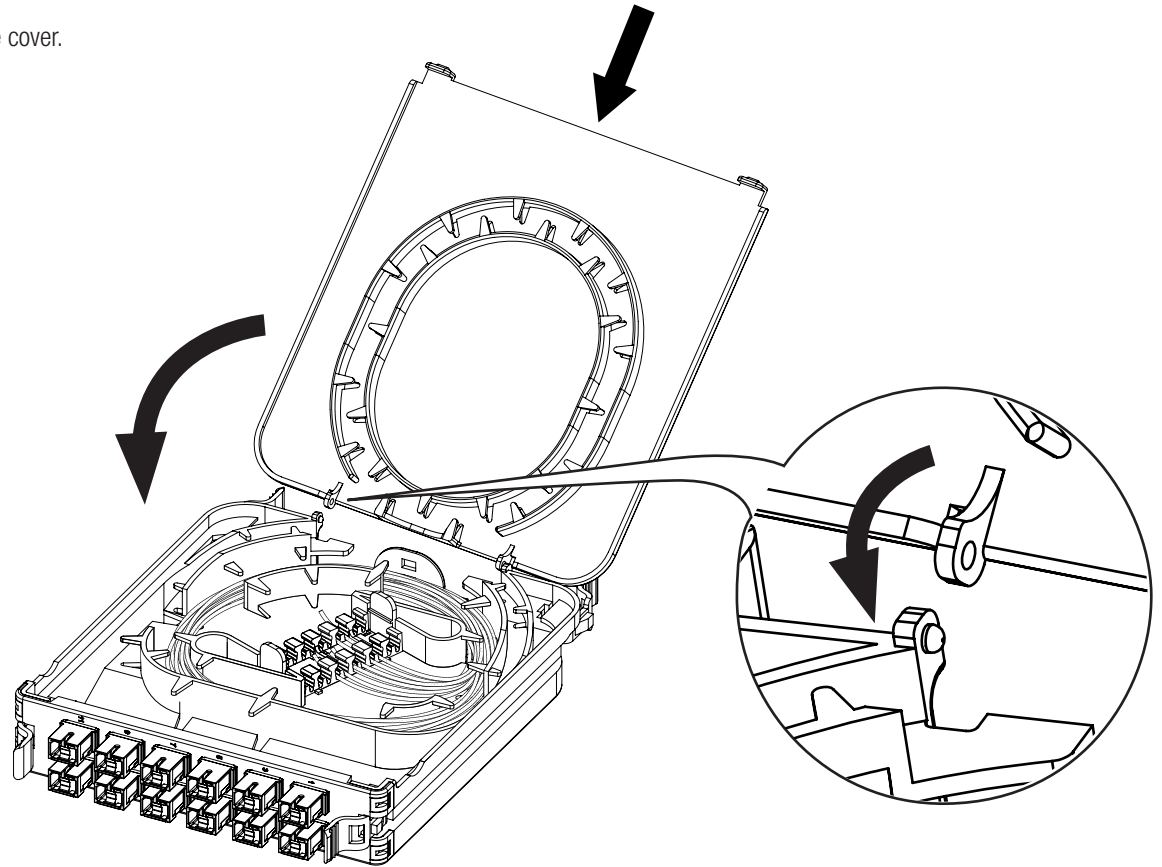

6 Flip the cassette.
Route the sub-unit cable under the routing tabs as shown.
Secure it with the provided cable tie.

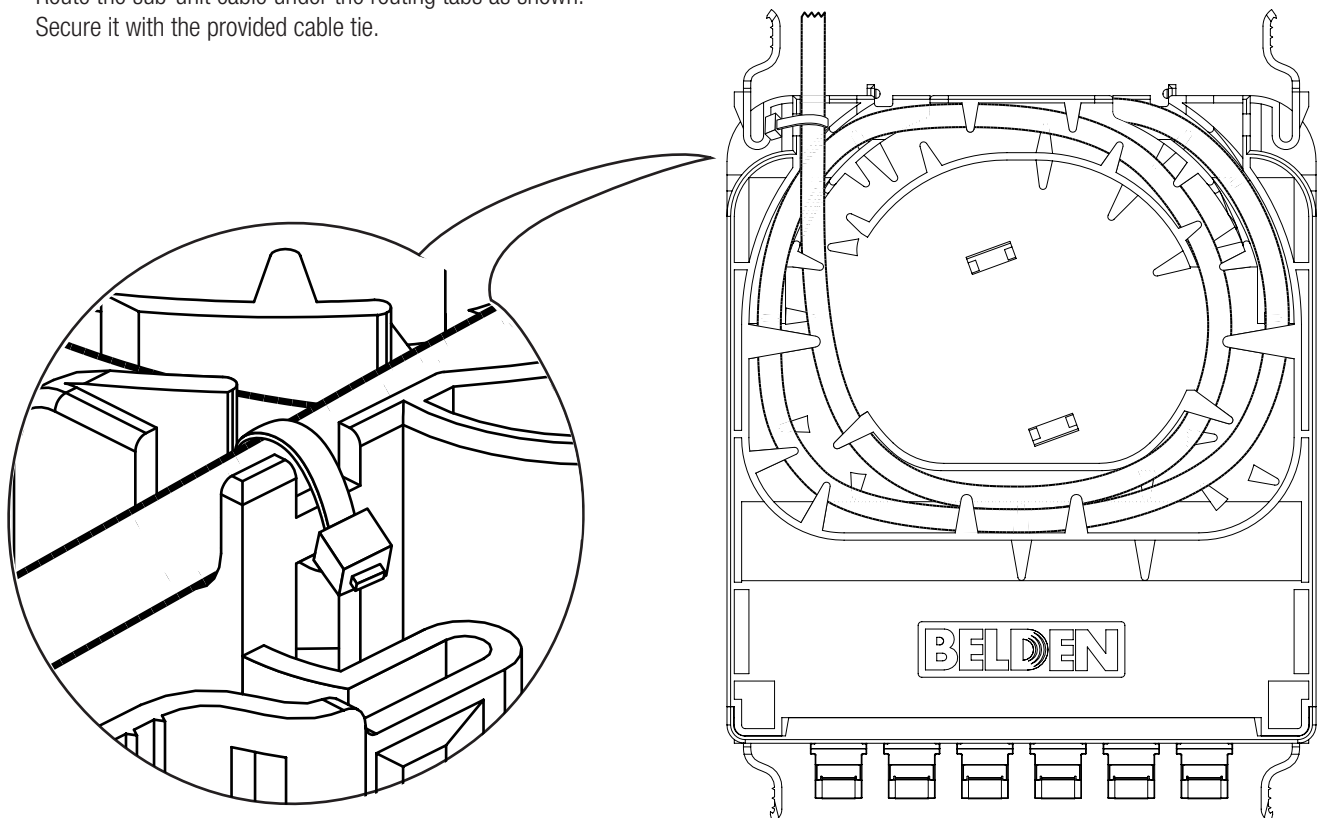

- 7** Flip the cassette.
Open the cover.
Mate connectors to adapters.

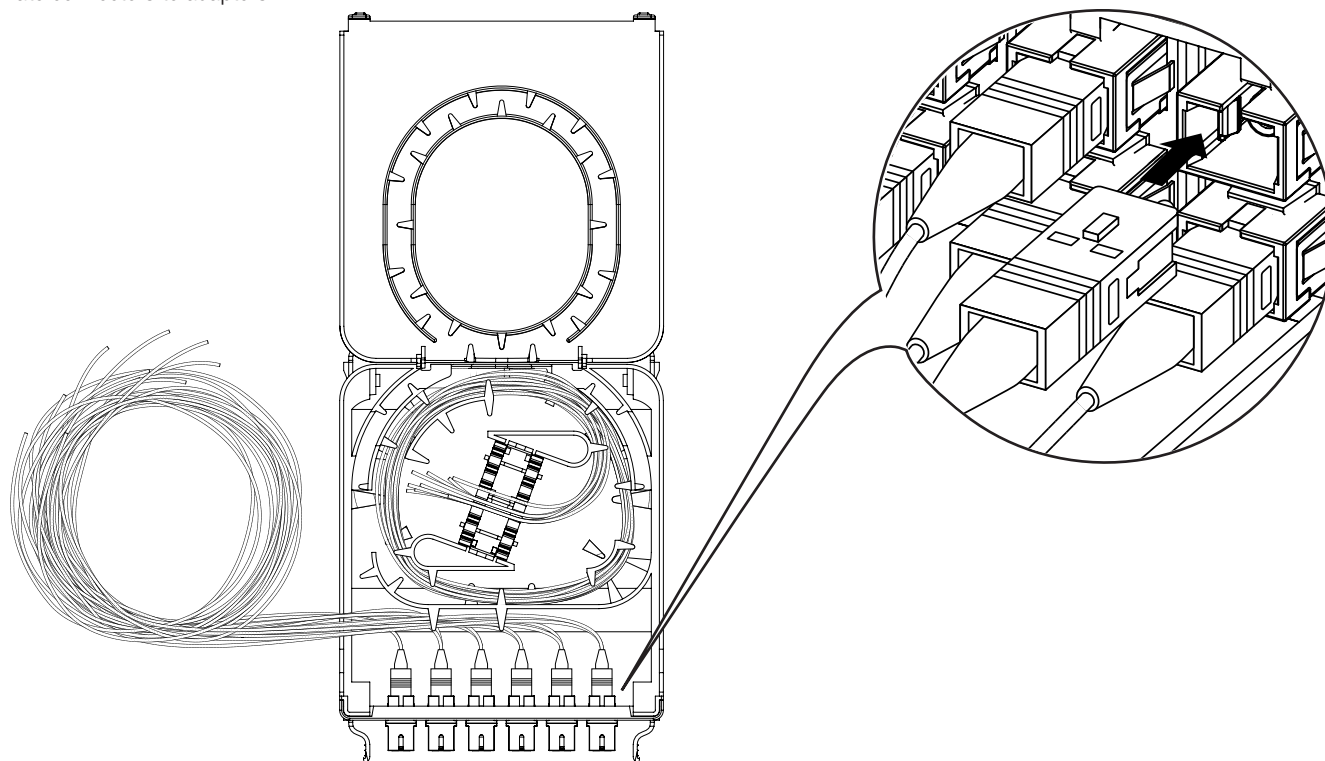

- 8** Route the pigtails as shown by looping twice (2) in the cover.
In order to prepare for splicing, unloop 900µm fiber from cassette.

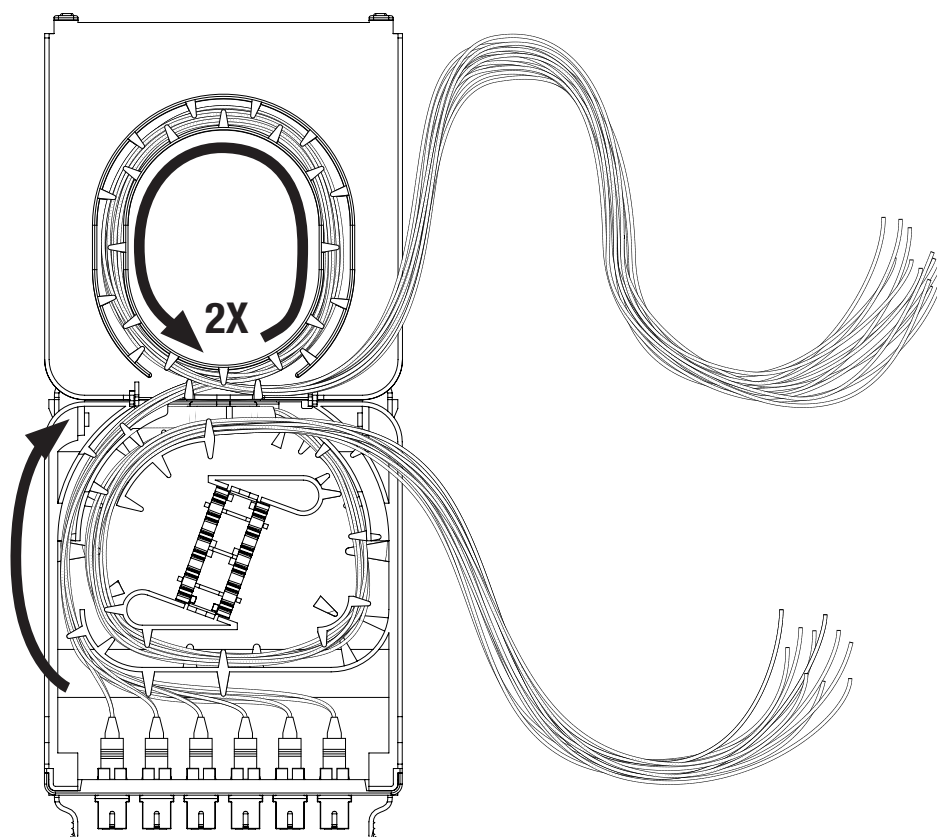

9 Splice the 900 μm fiber (tight buffer) to the pigtails.

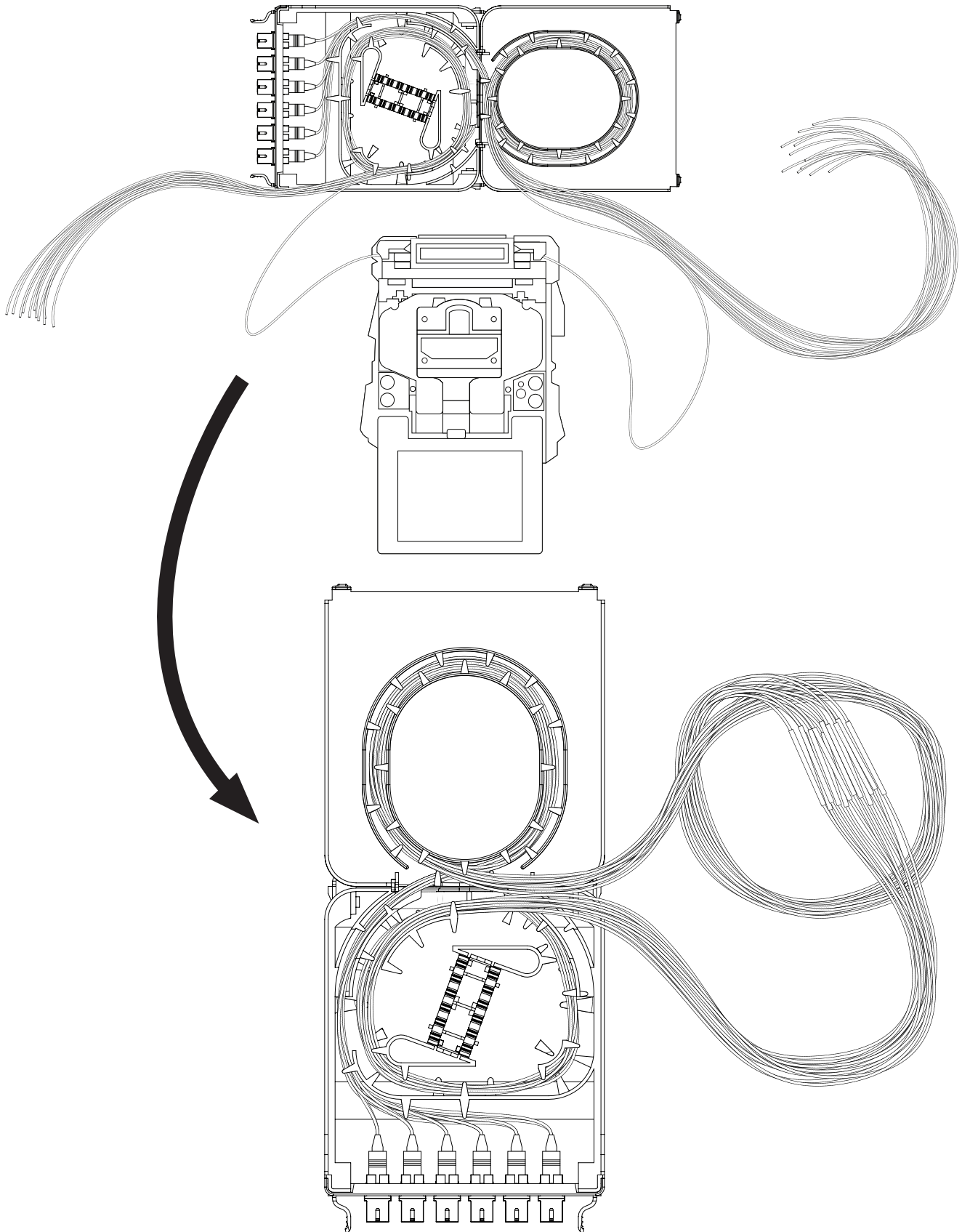

- 10** Route the pigtails by doing another loop in the cover.
Route the 900µm fiber (tight buffer) by doing another loop in the housing as shown.

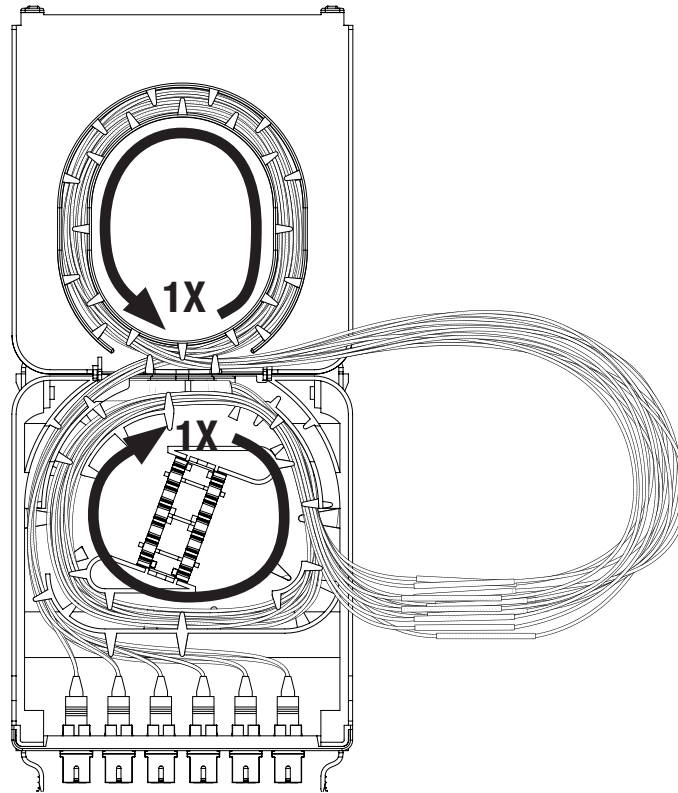

- 11** Insert the spliced fiber into the universal splice holder by doing an inverted "s" loop.

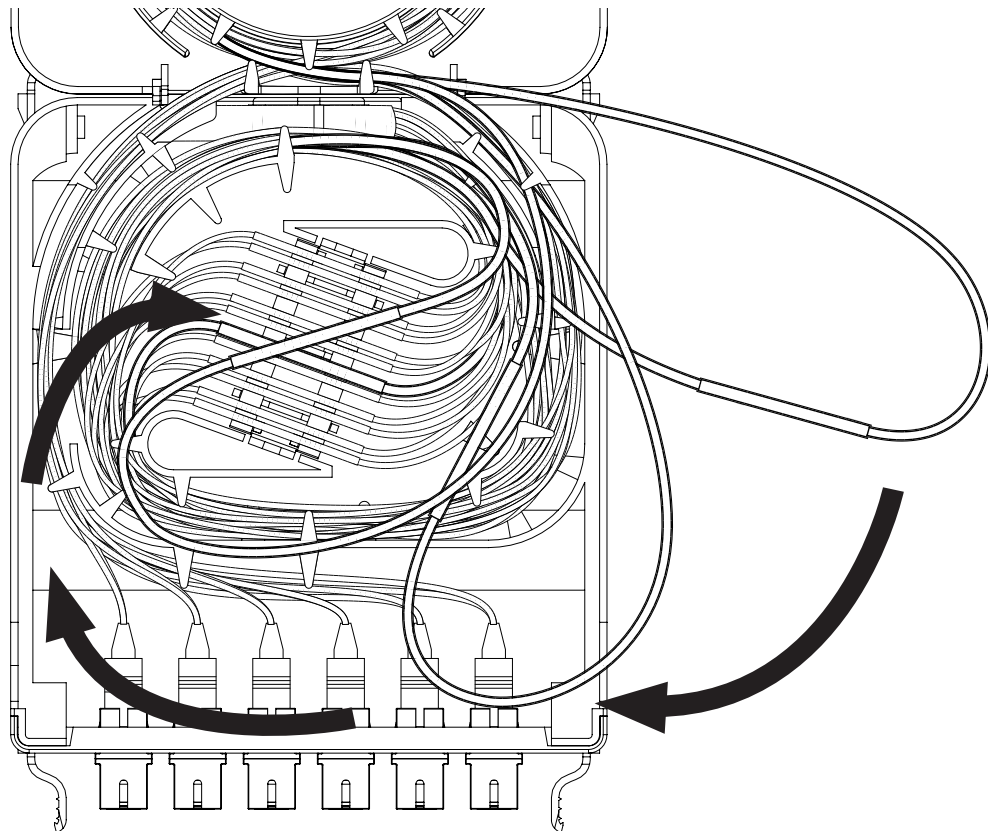

12 Manage the rest of the fiber as shown.
Store it under the routing tabs.

