



**HIRSCHMANN**

A **BELDEN** BRAND

# User Manual

## Installation Building Automation Switch BAS

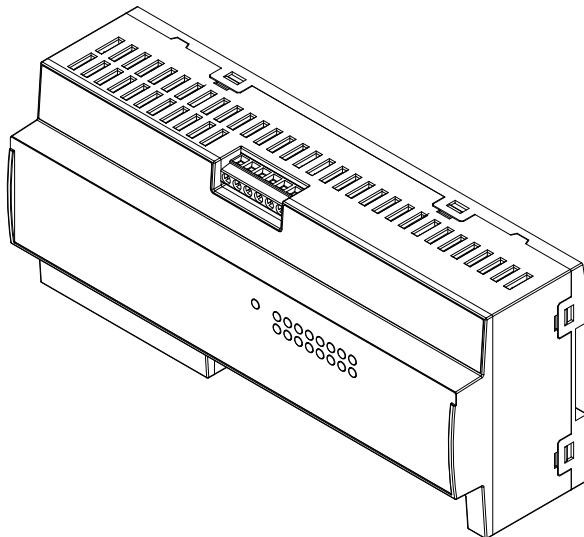

The naming of copyrighted trademarks in this manual, even when not specially indicated, should not be taken to mean that these names may be considered as free in the sense of the trademark and tradename protection law and hence that they may be freely used by anyone.

© 2021 Hirschmann Automation and Control GmbH

Manuals and software are protected by copyright. All rights reserved. The copying, reproduction, translation, conversion into any electronic medium or machine scannable form is not permitted, either in whole or in part. An exception is the preparation of a backup copy of the software for your own use.

The performance features described here are binding only if they have been expressly agreed when the contract was made. This document was produced by Hirschmann Automation and Control GmbH according to the best of the company's knowledge. Hirschmann reserves the right to change the contents of this document without prior notice. Hirschmann can give no guarantee in respect of the correctness or accuracy of the information in this document.

Hirschmann can accept no responsibility for damages, resulting from the use of the network components or the associated operating software. In addition, we refer to the conditions of use specified in the license contract.

You can get the latest version of this manual on the Internet at the Hirschmann product site ([www.hirschmann.com](http://www.hirschmann.com)).

Hirschmann Automation and Control GmbH  
Stuttgarter Str. 45-51  
72654 Neckartenzlingen  
Germany

# Contents

|   |           |
|---|-----------|
| <b>Important information</b>                  | <b>5</b>  |
| <b>Safety instructions</b>                    | <b>7</b>  |
| <b>About this Manual</b>                      | <b>13</b> |
| <b>Key</b>                                    | <b>14</b> |
| <b>1 Description</b>                          | <b>15</b> |
| 1.1 General device description                | 15        |
| 1.2 Device view                               | 15        |
| 1.2.1 Front view                              | 15        |
| 1.2.2 View from below                         | 16        |
| 1.3 Power supply                              | 17        |
| 1.3.1 Supply voltage LV                       | 17        |
| 1.3.2 Supply voltage HV                       | 17        |
| 1.4 Ethernet ports                            | 17        |
| 1.4.1 10/100/1000 Mbit/s twisted pair port    | 18        |
| 1.4.2 10/100 Mbit/s twisted pair port         | 18        |
| 1.4.3 Support of PoE                          | 18        |
| 1.4.4 10/100/1000 Mbit/s PoE port             | 20        |
| 1.4.5 10/100 Mbit/s PoE port                  | 20        |
| 1.5 Pin assignments                           | 21        |
| 1.6 Display elements                          | 22        |
| 1.6.1 Device state                            | 22        |
| 1.6.2 Port status                             | 22        |
| <b>2 Installation</b>                         | <b>23</b> |
| 2.1 Checking the package contents             | 23        |
| 2.2 Installing and grounding the device       | 23        |
| 2.2.1 Installing the device onto the DIN rail | 23        |
| 2.2.2 Grounding the device                    | 24        |
| 2.3 Connecting the terminal blocks            | 24        |
| 2.3.1 Supply voltage LV                       | 25        |
| 2.3.2 Supply voltage HV                       | 26        |

|          |   |           |
|----------|---|-----------|
| 2.4      | Connecting data cables                        | 26        |
| 2.5      | Attach touch protection                       | 27        |
| 2.6      | Operating the device                          | 27        |
| <b>3</b> | <b>Monitoring the ambient air temperature</b> | <b>28</b> |
| <b>4</b> | <b>Maintenance and service</b>                | <b>29</b> |
| <b>5</b> | <b>Disassembly</b>                            | <b>30</b> |
| 5.1      | Removing the device                           | 30        |
| <b>6</b> | <b>Technical data</b>                         | <b>31</b> |
| <b>A</b> | <b>Further support</b>                        | <b>38</b> |

# Important information

**Note:** Read these instructions carefully, and familiarize yourself with the device before trying to install, operate, or maintain it. The following notes may appear throughout this documentation or on the device. These notes warn of potential hazards or call attention to information that clarifies or simplifies a procedure.

## ■ Symbol explanation



This is a general warning symbol. This symbol alerts you to potential personal injury hazards. Observe all safety notes that follow this symbol to avoid possible injury or death.



If this symbol is displayed in addition to a safety instruction of the type “Danger” or “Warning”, it means that there is a danger of electric shock and failure to observe the instructions will inevitably result in injury.



This symbol indicates the danger of hot surfaces on the device. In connection with safety instructions, non-observance of the instructions will inevitably result in injuries.



## **DANGER**

**DANGER** draws attention to an immediately dangerous situation, which will **inevitably** result in a serious or fatal accident if not observed.



## **WARNING**

**WARNING** indicates a potentially hazardous situation which, if not avoided, **could** result in death or serious injury.



## **CAUTION**

**CAUTION** indicates a possible danger which, if not avoided, **may** result in minor injuries.

# NOTICE

**NOTE** provides information about procedures that do not involve the risk of injury.

# Safety instructions

## ■ General safety instructions

You operate this device with electricity. Improper usage of the device entails the risk of physical injury or significant property damage. The proper and safe operation of this device depends on proper handling during transportation, proper storage and installation, and careful operation and maintenance.

- Before connecting any cable, read this document, and the safety instructions and warnings.
- Operate the device with undamaged components exclusively.
- The device is free of any service components. In case of a damaged or malfunctioning device, turn off the supply voltage and return the device to Hirschmann for inspection.
- Disconnect the device from the power supply before mounting.

## ■ Certified usage

- Use the product only for the application cases described in the Hirschmann product information, including this manual.
- Operate the device only in a closed casing (distribution board).
- Operate the product only according to the technical specifications.  
[See "Technical data" on page 31.](#)
- Ensure that the minimum distance of 10 mm (0.39 in) between datalines/telecommunication lines and power lines is maintained.
- Connect to the product only components suitable for the requirements of the specific application case.

## ■ Strain relief

**Note:** If the strain relief is insufficient, there is a potential risk of torsion, contact problems and creeping interruptions.

- Relieve the connection points of cables and lines from mechanical stress.
- Design strain reliefs in such a way that they help prevent any mechanical damage to cables, wires or conductors caused by external influences or their own weight.
- To help prevent damage to device connections, connectors and cables, follow the instructions for proper installation in accordance with DIN VDE 0100-520:2013-06, sections 522.6, 522.7 and 522.13.

## ■ **Device casing**

Only technicians authorized by the manufacturer are permitted to open the casing.

- Never insert pointed objects (narrow screwdrivers, wires, etc.) into the device or into the connection terminals for electric conductors. Do not touch the connection terminals.
- Keep the ventilation slits free to ensure good air circulation.  
[See “General technical data” on page 31.](#)
- Mount the device in the vertical position.

## ■ **Qualification requirements for personnel**

- Only allow qualified personnel to work on the device.

Qualified personnel have the following characteristics:

- ▶ Qualified personnel are properly trained. Training as well as practical knowledge and experience make up their qualifications. This is the prerequisite for grounding and labeling circuits, devices, and systems in accordance with current standards in safety technology.
- ▶ Qualified personnel are aware of the dangers that exist in their work.
- ▶ Qualified personnel are familiar with appropriate measures against these hazards in order to reduce the risk for themselves and others.
- ▶ Qualified personnel receive training on a regular basis.

## ■ **National and international safety regulations**

Verify that the electrical installation meets local or nationally applicable safety regulations.

## ■ **Grounding the device**

The device is grounded via a 6-pin terminal block.

- Use a wire diameter for the ground conductor that is no smaller than the diameter of the supply voltage connection, however of at least 0.5 mm<sup>2</sup> (AWG20).

## ■ **Shielding ground**

The shielding ground of the connectable twisted pair cables is connected to the ground connection as a conductor.

- Beware of possible short circuits when connecting a cable section with conductive shielding braiding.



## ■ Requirements for connecting electrical wires

Before connecting the electrical wires, **always** verify that the requirements listed are complied with.

### General requirements for connecting electrical wires

#### The following requirements apply without restrictions:

- ▶ The electrical wires are voltage-free.
- ▶ The cables used are permitted for the temperature range of the application case.
- ▶ Relevant for North America:  
Exclusively use 60/75 °C (140/167 °F) or 75 °C (167 °F) copper (Cu) wire.
- ▶ Enable the supply voltage for the device only when the following requirements are fulfilled:
  - the terminal blocks are wired correctly
  - the device casing is closed

### Requirements for connecting the supply voltage

#### Supply voltage LV

#### Device variant

#### BAS20-8TX

#### The following requirements apply without restrictions:

- ▶ The supply voltage corresponds to the voltage specified on the type plate of the device.
- ▶ The power supply conforms to overvoltage category I or II.
- ▶ The power supply has an easily accessible disconnecting device (for example a switch or a plug). This disconnecting device is clearly identified. So in the case of an emergency, it is clear which disconnecting device belongs to which power supply cable.
- ▶ The power supply cable is suitable for the voltage, the current and the physical load. Hirschmann recommends a wire diameter of 0.5 mm<sup>2</sup> (AWG20).
- ▶ The cross-section of the ground conductor is the same size as or bigger than the cross-section of the power supply cables.

#### The following requirements apply alternatively:

- |               |   |
|---------------|---|
| Alternative 1 | The power supply complies with the requirements for a limited power source (LPS).   |
| Alternative 2 | <p><b>All</b> of the following requirements are complied with:</p> <ul style="list-style-type: none"><li>▶ The power supply complies with the requirements for a safety extra-low voltage (SELV).</li></ul> <p>Supply with DC voltage:</p> <ul style="list-style-type: none"><li>▶ A back-up fuse suitable for DC voltage is located in the plus conductor of the power supply.<br/>The minus conductor is on ground potential. Otherwise, a back-up fuse is also located in the minus conductor.<br/>Regarding the properties of this back-up fuse:<br/><a href="#">See “General technical data” on page 31.</a></li></ul> <p>Supply with AC voltage:</p> <ul style="list-style-type: none"><li>▶ A back-up fuse is located in the outer conductor of the power supply.<br/>The neutral conductor is on ground potential at both voltage inputs.<br/>Otherwise, a back-up fuse is also located in the neutral conductor.<br/>Regarding the properties of this back-up fuse:<br/><a href="#">See “General technical data” on page 31.</a></li></ul> |

## Requirements for connecting the supply voltage

### Supply voltage HV

#### Device variants

BAS20-8TX-HV, BAS22-8TX-HV...

#### The following requirements apply without restrictions:

- ▶ The supply voltage corresponds to the voltage specified on the type plate of the device.
- ▶ The power supply complies with overvoltage category I or II or III.
- ▶ The power supply has an easily accessible disconnecting device (for example a switch or a plug). This disconnecting device is clearly identified. So in the case of an emergency, it is clear which disconnecting device belongs to which power supply cable.
- ▶ The power supply cable is suitable for the voltage, the current and the physical load. Hirschmann recommends a wire diameter of 0.5 mm<sup>2</sup> (AWG20).
- ▶ A back-up fuse is located in the outer conductor of the power supply. The neutral conductor is on ground potential at both voltage inputs. Otherwise, a back-up fuse is also located in the neutral conductor. Regarding the properties of this back-up fuse:  
[See "General technical data" on page 31.](#)
- ▶ The cross-section of the ground conductor is the same size as or bigger than the cross-section of the power supply cables.

#### ■ **Supply voltage**

The supply voltage is only connected with the ground connection via protective elements.

#### ■ **CE marking**

The labeled devices comply with the regulations contained in the following European directive(s):

2011/65/EU and 2015/863/EU (RoHS)

Directive of the European Parliament and of the Council on the restriction of the use of certain hazardous substances in electrical and electronic equipment.

2014/30/EU (EMC)

Directive of the European Parliament and of the Council on the harmonisation of the laws of the Member States relating to electromagnetic compatibility.

In accordance with the above-named EU directive(s), the EU conformity declaration will be available to the relevant authorities at the following address:

Hirschmann Automation and Control GmbH  
Stuttgarter Str. 45-51  
72654 Neckartenzlingen  
Germany

You find the EU conformity declaration as PDF file for downloading on the Internet at: <https://www.doc.hirschmann.com/certificates.html>

The product can be used in the industrial sector.

- ▶ Interference immunity: EN 61000-6-2
- ▶ Emitted interference: EN 55032
- ▶ Safety: EN IEC 61010-2-201

You find more information on technical standards here:

[“Technical data” on page 31](#)

**Note:** The assembly guidelines provided in these instructions must be strictly adhered to in order to observe the EMC threshold values.

## ■ **FCC note**

### **Supplier's Declaration of Conformity 47 CFR § 2.1077 Compliance Information**

Building Automation Switch  
BAS

### **U.S. Contact Information**

Belden – St. Louis  
1 N. Brentwood Blvd. 15th Floor  
St. Louis, Missouri 63105, United States  
Phone: 314.854.8000

This device complies with part 15 of the FCC Rules. Operation is subject to the following two conditions: (1) This device may not cause harmful interference, and (2) this device must accept any interference received, including interference that may cause undesired operation.

**Note:** This equipment has been tested and found to comply with the limits for a Class A digital device, pursuant to part 15 of the FCC Rules. These limits are designed to provide reasonable protection against harmful interference when the equipment is operated in a commercial environment. This equipment generates, uses, and can radiate radio frequency energy and, if not installed and used in accordance with the instruction manual, may cause harmful interference to radio communications. Operation of this equipment in a residential area is likely to cause harmful interference in which case the user will be required to correct the interference at his own expense.

## ■ **Recycling note**

After usage, this device must be disposed of properly as electronic waste, in accordance with the current disposal regulations of your county, state, and country.

# About this Manual

The “Installation” user manual contains a device description, safety instructions, a description of the display, and the other information that you need to install the device.

Documentation mentioned in the “User Manual Installation” that is not supplied with your device as a printout can be found as PDF files for downloading on the Internet at: <https://www.doc.hirschmann.com>

# Key

The symbols used in this manual have the following meanings:

|   |            |
|---|------------|
| ▶ | Listing    |
| □ | Work step  |
| ■ | Subheading |

# 1 Description

## 1.1 General device description

The device is designed for the special requirements of building automation. The device is designed for installation in electrical distribution boards and small casings for rapid mounting on a 35 mm (1.38 in) mounting rail in accordance with EN 60715. The device meets the relevant industry standards, provides very high operational reliability, even under extreme conditions, and also long-term reliability and flexibility.

## 1.2 Device view

### 1.2.1 Front view

#### ■ Example of a device variant without PoE

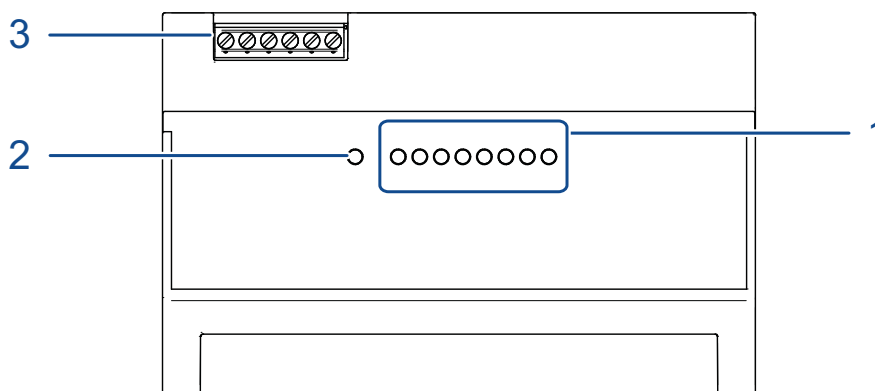

Figure 1: Example of a device variant without PoE

|   |                                       |
|---|---------------------------------------|
| 1 | LED display elements for port status  |
| 2 | LED display element for device status |
| 3 | 6-pin terminal block with screw lock  |

## ■ Example of a device variant with PoE

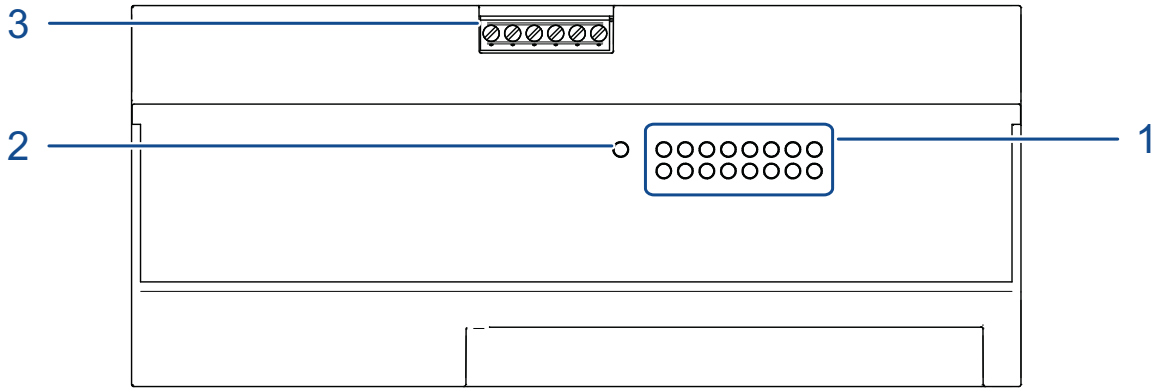

Figure 2: Example of a device variant with PoE

|   |                                       |
|---|---------------------------------------|
| 1 | LED display elements for port status  |
| 2 | LED display element for device status |
| 3 | 6-pin terminal block with screw lock  |

### 1.2.2 View from below

## ■ Example of a device variant without PoE

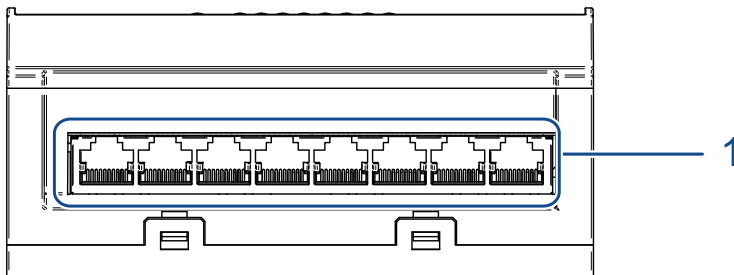

Figure 3: Example of a device variant without PoE

|   |   |
|---|---|
| 1 | 8 × RJ45 socket for 10/100/1000 Mbit/s Twisted Pair connections |
|---|---|



## ■ Example of a device variant with PoE

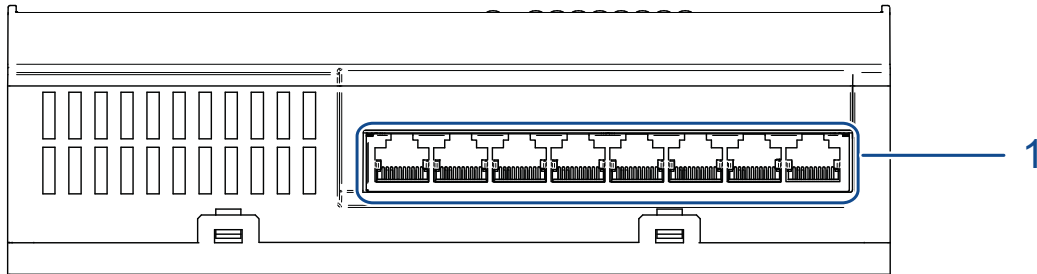

Figure 4: Example of a device variant with PoE

---

1      8 × RJ45 socket for 10/100/1000 Mbit/s Twisted Pair connections

---

## 1.3 Power supply

### 1.3.1 Supply voltage LV

The following options for power supply are available:

- ▶ 6-pin terminal block

You will find information on connecting the supply voltage here:  
[“Connecting the terminal blocks” on page 24](#)

### 1.3.2 Supply voltage HV

The following options for power supply are available:

- ▶ 6-pin terminal block

You will find information on connecting the supply voltage here:  
[“Connecting the terminal blocks” on page 24](#)

## 1.4 Ethernet ports

You can connect terminal devices and other segments at the ports of the device via twisted pair cables.

You find information on the pin assignments for making patch cables here:  
[“Pin assignments” on page 21](#)

### **1.4.1 10/100/1000 Mbit/s twisted pair port**

This port is an RJ45 socket.

The 10/100/1000 Mbit/s twisted pair port allows you to connect network components according to the IEEE 802.3 10BASE-T/100BASE-TX/1000BASE-T standard.

This port supports:

- ▶ Autonegotiation
- ▶ Autopolarity
- ▶ Autocrossing
- ▶ 1000 Mbit/s full duplex
- ▶ 100 Mbit/s half-duplex mode, 100 Mbit/s full duplex mode
- ▶ 10 Mbit/s half-duplex mode, 10 Mbit/s full duplex mode

### **1.4.2 10/100 Mbit/s twisted pair port**

This port is an RJ45 socket.

The 10/100 Mbit/s twisted pair port allows you to connect network components according to the IEEE 802.3 10BASE-T/100BASE-TX standard.

This port supports:

- ▶ Autonegotiation
- ▶ Autopolarity
- ▶ Autocrossing
- ▶ 100 Mbit/s half-duplex mode, 100 Mbit/s full duplex mode
- ▶ 10 Mbit/s half-duplex mode, 10 Mbit/s full duplex mode

### **1.4.3 Support of PoE**

The device variants with PoE support Power over Ethernet (PoE) in accordance with IEEE 802.3af.

The PoE ports allow the connection and remote supply of, for example, IP telephones (Voice over IP), webcams, sensors, printer servers and WLAN access points. With PoE, power is supplied to these terminal devices through the twisted pair cable.

The Power over Ethernet function is activated both globally and on the PoE-capable ports on delivery. You will recognize the PoE-capable devices from the printed PoE logo.

The devices are supplied with PoE voltage via the internal voltage supply. The PoE voltage to the twisted-pair cables is supplied via the wire pairstransmitting the signal (phantom voltage).

The PoE voltage is uncoupled from the power supply. The individual ports are not electrically insulated from each other.

# NOTICE

## POTENTIAL EQUIPMENT DAMAGE

Ensure that the device does not exceed the specified maximum PoE power output.

**Failure to follow these instructions can result in equipment damage.**

For the maximum power available to PoE end devices in total, see the technical data: [See “Power consumption/power output” on page 35.](#)

#### **1.4.4 10/100/1000 Mbit/s PoE port**

This port is an RJ45 socket.

The 10/100/1000 Mbit/s twisted pair port allows you to connect network components according to the IEEE 802.3 10BASE-T/100BASE-TX/1000BASE-T standard.

This port supports:

- ▶ Autonegotiation
- ▶ Autopolarity
- ▶ Autocrossing
- ▶ 1000 Mbit/s full duplex
- ▶ 100 Mbit/s half-duplex mode, 100 Mbit/s full duplex mode
- ▶ 10 Mbit/s half-duplex mode, 10 Mbit/s full duplex mode
- ▶ Power over Ethernet (PoE)

#### **1.4.5 10/100 Mbit/s PoE port**

This port is an RJ45 socket.

The 10/100 Mbit/s twisted pair port allows you to connect network components according to the IEEE 802.3 10BASE-T/100BASE-TX standard.

This port supports:

- ▶ Autonegotiation
- ▶ Autopolarity
- ▶ Autocrossing
- ▶ 100 Mbit/s half-duplex mode, 100 Mbit/s full duplex mode
- ▶ 10 Mbit/s half-duplex mode, 10 Mbit/s full duplex mode
- ▶ Power over Ethernet (PoE)

## 1.5 Pin assignments

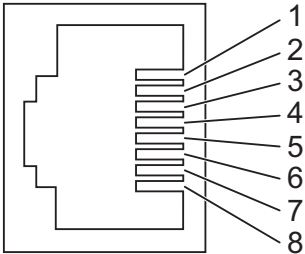
| RJ45  | Pin               | 10/100 Mbit/s | 1000 Mbit/s |
|---|-------------------|---------------|-------------|
|  | <b>MDI mode</b>   |               |             |
|   | 1                 | TX+           | BI_DA+      |
|   | 2                 | TX-           | BI_DA-      |
|   | 3                 | RX+           | BI_DB+      |
|   | 4                 | —             | BI_DC+      |
|   | 5                 | —             | BI_DC-      |
|   | 6                 | RX-           | BI_DB-      |
|   | 7                 | —             | BI_DD+      |
|   | 8                 | —             | BI_DD-      |
|   | <b>MDI-X mode</b> |               |             |
|   | 1                 | RX+           | BI_DB+      |
|   | 2                 | RX-           | BI_DB-      |
|   | 3                 | TX+           | BI_DA+      |
|   | 4                 | —             | BI_DD+      |
|   | 5                 | —             | BI_DD-      |
|   | 6                 | TX-           | BI_DA-      |
| 7   | —                 | BI_DC+        |             |
| 8   | —                 | BI_DC-        |             |

## 1.6 Display elements

After the supply voltage is switched on, the device performs a self-test. During this process, various LEDs light up.

### 1.6.1 Device state

This LED provides information on the status of the power supply.

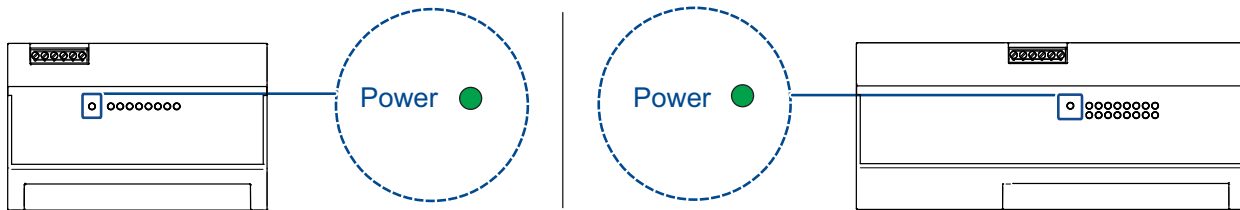

Figure 5: LED display elements for device status

| Color | Activity  | Meaning  |
|-------|-----------|--|
| green | lights up | Supply voltage is on<br>Device is ready for operation          |
| —     | none      | Supply voltage is too low<br>Device is not ready for operation |

### 1.6.2 Port status

These LEDs provide port-related information.

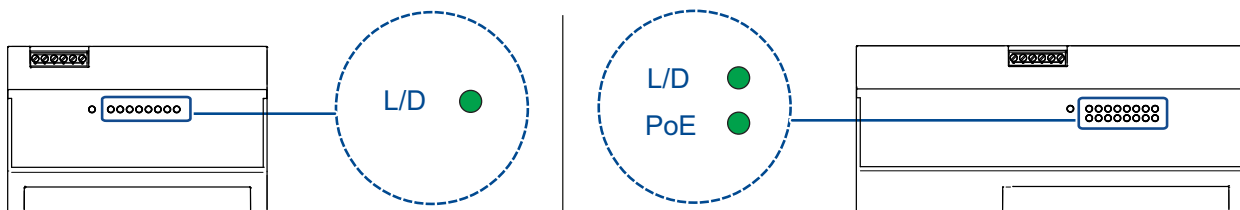

Figure 6: LED display elements for port status

| L/D<br>(link status/data) | Color | Activity                | Meaning  |
|---------------------------|-------|-------------------------|--|
|                           | green | lights up               | Device detects a valid link  |
|                           | —     | flashing                | Device is transmitting and/or receiving data   |
|                           | —     | none                    | Device detects an invalid or missing link  |
| PoE                       | Color | Activity                | Meaning  |
|                           | green | lights up               | Powered device is supplied with power  |
|                           | —     | flashes 1 time a period | no power supply of the Powered Device as the power output required by the Powered Device cannot be provided on this port |
|                           | —     | none                    | No powered device connected  |

## 2 Installation

On delivery, the device is ready for operation.

Perform the following steps to install the device:

- ▶ [Checking the package contents](#)
- ▶ [Installing and grounding the device](#)
- ▶ [Connecting the terminal blocks](#)
- ▶ [Connecting data cables](#)
- ▶ [Attach touch protection](#)
- ▶ [Operating the device](#)

### 2.1 Checking the package contents

- Check whether the package includes all items named in the section [“Scope of delivery” on page 36](#).
- Check the individual parts for transport damage.

### 2.2 Installing and grounding the device

You have the following options for mounting your device:

- ▶ [Installing the device onto the DIN rail](#)

#### 2.2.1 Installing the device onto the DIN rail

Prerequisite:

The device is for mounting on a 35 mm DIN rail in accordance with DIN EN 60715.

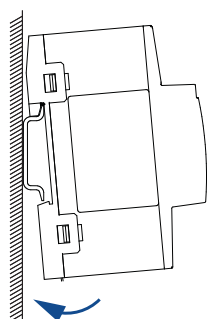

Figure 7: Mounting on the DIN rail

Perform the following work steps:

- Slide the upper snap-in guide of the device into the DIN rail.
- Push the device downwards and onto the DIN rail.
- Snap-in the device.

### **2.2.2 Grounding the device**

Prerequisites:

- Use a wire diameter for the ground conductor that is no smaller than the diameter of the supply voltage connection, however of at least 0.5 mm<sup>2</sup> (AWG20).

The device is grounded via a 6-pin terminal block.

## **2.3 Connecting the terminal blocks**



### **WARNING**

#### **ELECTRIC SHOCK**

Exclusively connect a supply voltage that corresponds to the type plate of your device.

Never insert sharp objects (small screwdrivers, wires, etc.) into the connection terminals for the supply voltage, and do not touch the terminals.

**Failure to follow this instruction can result in death, serious injury, or equipment damage.**

The supply voltage is only connected with the ground connection via protective elements.



## 2.3.1 Supply voltage LV

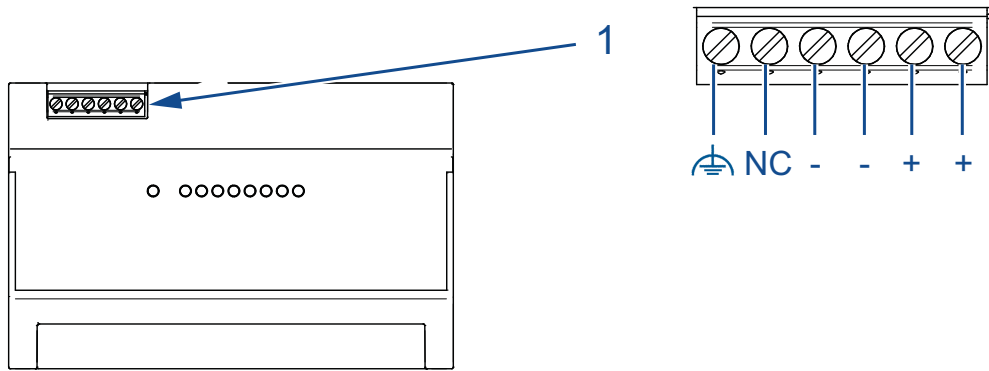

Figure 8: (1) Connection for DC voltage and AC voltage on the device

| Type of the voltages that can be connected | Specification of the supply voltage   |
|--|---|
| DC voltage                                 | Rated voltage range DC:<br>12 V DC ... 48 V DC<br>Voltage range DC incl. maximum tolerances:<br>9.6 V DC ... 60 V DC                      |
| AC voltage                                 | Rated voltage range AC:<br>24 V AC, 50 Hz ... 60 Hz<br>Voltage range AC incl. maximum tolerances:<br>18 V AC ... 30 V AC, 47 Hz ... 63 Hz |

Table 1: Type and specification of the supply voltage

Perform the following work steps:

- Verify the required conditions for connecting the voltage supply.  
See [“Requirements for connecting electrical wires” on page 9.](#)
- Connect the wires according to the pin assignment on the device with the clamps.
- Fasten the wires in the terminal block by tightening the terminal screws.

## 2.3.2 Supply voltage HV

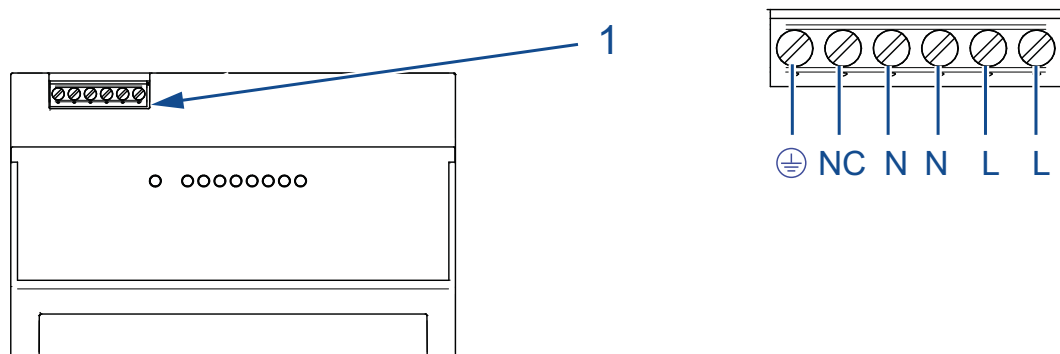

Figure 9: (1) AC voltage connection on the device

| Type of the voltages that can be connected | Specification of the supply voltage  |
|--|--|
| AC voltage                                 | Rated voltage range AC:<br>100 V AC ... 240 V AC, 50 Hz ... 60 Hz<br>Voltage range AC incl. maximum tolerances:<br>85 V AC ... 264 V AC, 47 Hz ... 63 Hz |

Table 2: Type and specification of the supply voltage

Perform the following work steps:

- Verify the required conditions for connecting the voltage supply.  
[See “Requirements for connecting electrical wires” on page 9.](#)
- Connect the wires according to the pin assignment on the device with the clamps.
- Fasten the wires in the terminal block by tightening the terminal screws.

## 2.4 Connecting data cables

Note the following general recommendations for data cable connections in environments with high electrical interference levels:

- Keep the length of the data cables as short as possible.
- Use optical data cables for the data transmission between the buildings.
- Ensure that the minimum distance of 10 mm (0.39 in) between datalines/ telecommunication lines and power lines is maintained.
- When using copper cables, provide a sufficient separation between the power supply cables and the data cables. Ideally, install the cables in separate cable channels.

- Verify that power supply cables and data cables do not run parallel over longer distances. To reduce inductive coupling, verify that the power supply cables and data cables cross at a 90° angle.
- Connect the data cables according to your requirements.  
[See “Ethernet ports” on page 17.](#)

## **2.5 Attach touch protection**

- Attach a suitable touch protection.

## **2.6 Operating the device**

By connecting the supply voltage via the terminal block, you start the operation of the device.

### **3 Monitoring the ambient air temperature**

Operate the device below the specified maximum ambient air temperature exclusively.

See [“General technical data” on page 31](#).

The ambient air temperature is the temperature of the air at a distance of 5 cm (2 in) from the device. It depends on the installation conditions of the device, for example the distance from other devices or other objects, and the output of neighboring devices.

## 4 Maintenance and service

When designing this device, Hirschmann largely avoided using high-wear parts. The parts subject to wear and tear are dimensioned to last longer than the lifetime of the product when it is operated normally. Operate this device according to the specifications.

Depending on the degree of pollution in the operating environment, check at regular intervals that the ventilation slots in the device are not obstructed.



### **CAUTION**

#### **RISK OF TRANSIENTS OR ELECTROSTATIC DISCHARGES**

Do not open the housing.

**Failure to follow these instructions can result in injury or equipment damage.**

**Note:** You find information on settling complaints on the Internet at <http://www.beldensolutions.com/en/Service/Repairs/index.phtml>.

## 5 Disassembly

### 5.1 Removing the device

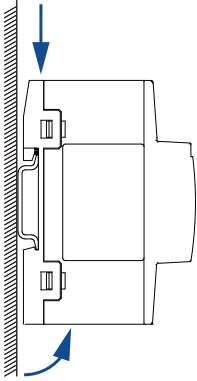

Figure 10: Removal from the DIN rail

Perform the following work steps:

- Disable the supply voltage.
- Remove the touch protection.
- Disconnect the power supply cables and signal lines.
- Disconnect the data cables.
- Disconnect the grounding.
- Press the device downwards and tilt the lower side towards you, then pull the device upwards away from the DIN rail.

## 6 Technical data

### ■ General technical data

|                         |  |  |  |
|-------------------------|--|--|--|
| Dimensions<br>W × H × D | Building Automation Switch             | See "Dimension drawings" on page 33.                         |  |
| Module width            | BAS20-8TX                              | 8 modules  |  |
|                         | BAS20-8TX-HV                           | 8 modules  |  |
|                         | BAS22-8TX-HV-55                        | 12 modules   |  |
|                         | BAS22-8TX-HV-110                       | 12 modules   |  |
| Weight                  | BAS20-8TX                              | 250 g (8.82 oz)  |  |
|                         | BAS20-8TX-HV                           | 250 g (8.82 oz)  |  |
|                         | BAS22-8TX-HV-55                        | 410 g (14.46 oz)   |  |
|                         | BAS22-8TX-HV-110                       | 410 g (14.46 oz)   |  |
| Supply voltage LV       | ▶ 1 voltage input                      |  |  |
|                         | ▶ Safety extra-low voltage             |  |  |
|                         | Rated voltage range                    | 12 V DC ... 48 V DC<br>24 V AC, 50 Hz ... 60 Hz              |  |
|                         | Voltage range incl. maximum tolerances | 9.6 V DC ... 60 V DC<br>18 V AC ... 30 V AC, 47 Hz ... 63 Hz |  |
|                         | Connection type                        | 6-pin terminal block with screw lock                         |  |
|                         |  | Stripping length   | 6 mm (0.24 in)                                 |
|                         |  | Tightening torque  | 4.4 lb-in ... 5.3 lb-in<br>(0.5 Nm ... 0.6 Nm) |
|                         |  | min. conductor diameter                                      | AWG26 (0.14 mm <sup>2</sup> )                  |
|                         |  | max. conductor diameter                                      | AWG16 (1.5 mm <sup>2</sup> )                   |
|                         | Power loss buffer                      | 10 ms at 20.4 V DC   |  |
| Back-up fuse            | 2 A ... 4 A, slow blow                 |  |  |
| Peak inrush current     | 4 A                                    |  |  |
| Overvoltage category    | Category II according to EN 60664-1    |  |  |

|   |  |  |
|---|--|--|
| Supply voltage HV                                   | ▶ 1 voltage input  |  |
| Rated voltage range                                 | 100 V AC ... 240 V AC, 50 Hz ... 60 Hz   |  |
| Voltage range incl. maximum tolerances              | 85 V AC ... 264 V AC, 47 Hz ... 63 Hz  |  |
| Connection type                                     | 6-pin terminal block with screw lock   |  |
| Stripping length                                    | 6 mm (0.24 in)   |  |
| Tightening torque                                   | 4.4 lb-in ... 5.3 lb-in<br>(0.5 Nm ... 0.6 Nm)                                       |  |
| min. conductor diameter                             | AWG26 (0.14 mm <sup>2</sup> )  |  |
| max. conductor diameter                             | AWG16 (1.5 mm <sup>2</sup> )   |  |
| Power loss buffer                                   | 10 ms at 115 V AC<br>15 ms at 230 V AC   |  |
| Back-up fuse  | 16 A with 1.5 mm <sup>2</sup> (AWG16) or smaller according to the wire diameter used |  |
| Peak inrush current                                 | 30 A at 115 V AC<br>60 A at 230 V AC   |  |
| Overvoltage category up to 2000 m ASL (6562 ft ASL) | Category III according to EN 60664-1   |  |
| Overvoltage category above 2000 m ASL (6562 ft ASL) | Category II according to EN 60664-1  |  |
| Climatic conditions during operation                | Ambient air temperature <sup>a</sup>   | -5°C ... +60 °C (+23 °F ... +140 °F)<br>Derating   |
|   | Humidity   | 20 % ... 90 %<br>(non-condensing)  |
|   | Air pressure   | Without derating<br>▶ min. 795 hPa (+6562 ft; +2000 m)<br>▶ max. 1060 hPa (-400 m; -1312 ft)<br>With derating<br>-5 °C ... +50 °C (+23 °F ... +122 °F)<br>▶ min. 700 hPa (+3000 m; +9842 ft)                               |
| Climatic conditions during storage                  | Ambient air temperature <sup>a</sup>   | -40 °C ... +85 °C (-40 °F ... +185 °F) up to 3 months<br>-40 °C ... +70 °C (-40 °F ... +158 °F) up to 1 year<br>-40 °C ... +50 °C (-40 °F ... +122 °F) up to 2 years<br>0 °C ... +30 °C (+32 °F ... +86 °F) up to 10 years |
|   | Humidity   | 10 % ... 95 %<br>(non-condensing)  |
|   | Air pressure   | ▶ min. 600 hPa (+4000 m; +13123 ft)<br>▶ max. 1060 hPa (-400 m; -1312 ft)  |
|   | Pollution degree   | 2 according to EN 60664-1  |
| Protection classes                                  | Degree of protection   | IP20   |
| Flammability classification                         |  | V-0 as per UL 94   |

a. Temperature of the ambient air at a distance of 5 cm (2 in) from the device



## ■ Dimension drawings

|      |
|------|
| mm   |
| inch |

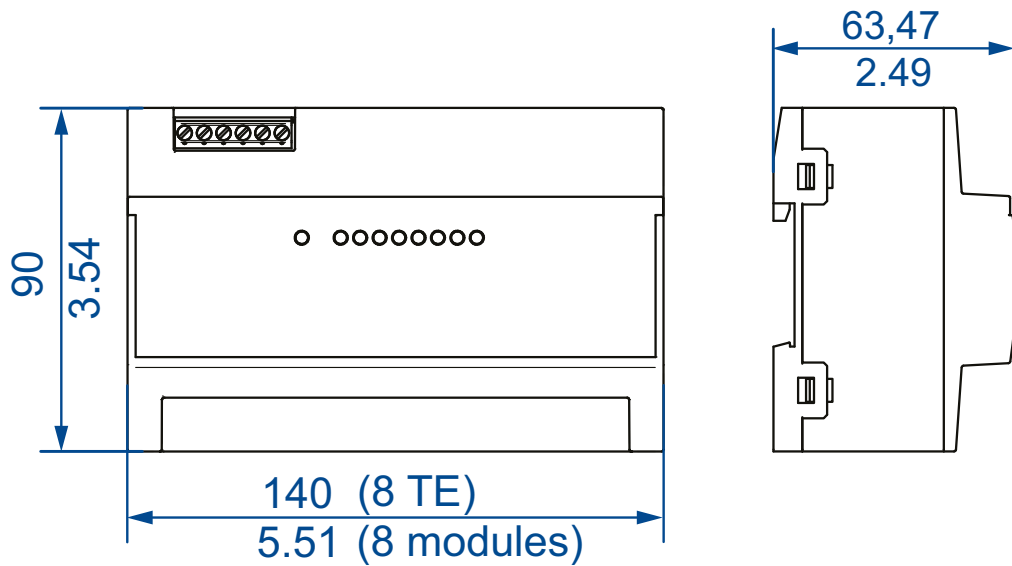

Figure 11: Device variants without PoE

|      |
|------|
| mm   |
| inch |

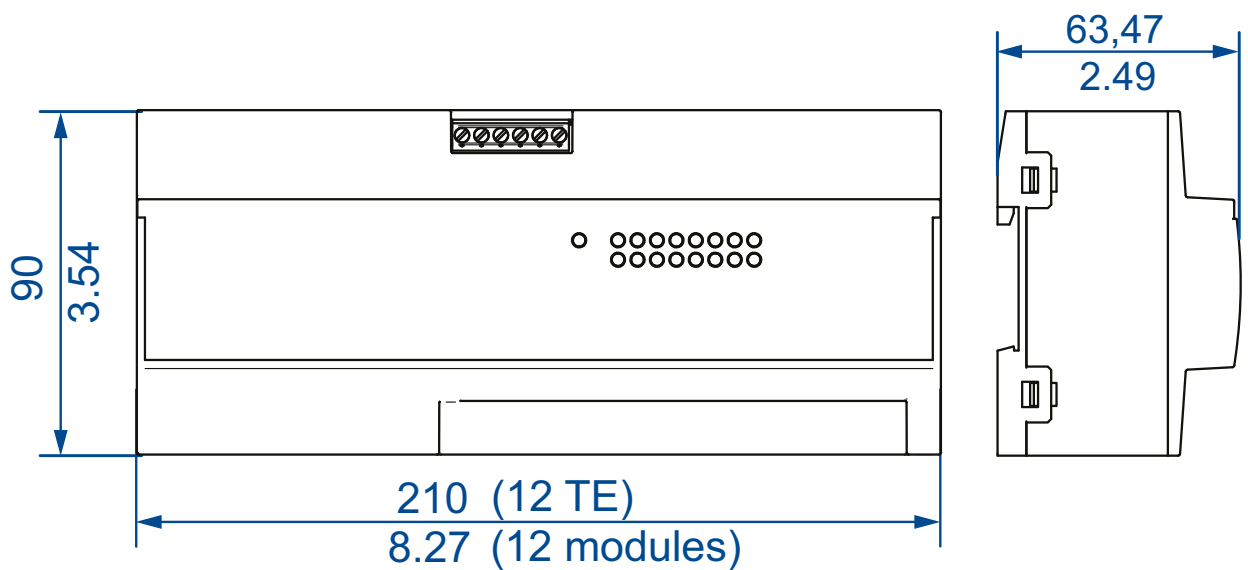

Figure 12: Device variants with PoE

## ■ EMC and immunity

| <b>EMC interference emission</b>             |                       |  |
|--|-----------------------|--|
| <b>Radiated emission</b>                     |                       |  |
| FCC 47 CFR Part 15                           |                       | Class A  |
| EN 55032                                     |                       | Class A  |
| EN 61000-3-2                                 |                       | Class A  |
| EN 61000-6-4                                 |                       | Fulfilled  |
| <b>Conducted emission</b>                    |                       |  |
| FCC 47 CFR Part 15                           |                       | Class A  |
| EN 55032                                     |                       | Class A  |
| EN 61000-3-2                                 |                       | Class A  |
| EN 61000-6-4                                 |                       | Fulfilled  |
| <b>EMC interference immunity</b>             |                       |  |
| <b>Electrostatic discharge</b>               |                       |  |
| EN 61000-4-2                                 | Contact discharge     | ±4 kV  |
| IEEE C37.90.3                                |                       |  |
| EN 61000-4-2                                 | Air discharge         | ±8 kV  |
| IEEE C37.90.3                                |                       |  |
| <b>Electromagnetic field</b>                 |                       |  |
| EN 61000-4-3                                 | 80 MHz ... 1000 MHz   | max. 10 V/m  |
|  | 1000 MHz ... 6000 MHz | max. 3 V/m   |
| <b>Fast transients (burst)</b>               |                       |  |
| EN 61000-4-4                                 | DC supply connection  | 2 kV   |
| EN 61000-4-4                                 | Data line             | 2 kV (U/UTP)<br>4 kV (SF/UTP)  |
| <b>Voltage surges - DC supply connection</b> |                       |  |
| EN 61000-4-5                                 | line/ground           | 1 kV<br>Supply voltage LV<br>2 kV<br>Supply voltage HV                 |
| EN 61000-4-5                                 | line/line             | 0.5 kV<br>Supply voltage LV<br>1 kV<br>Supply voltage HV               |
| <b>Voltage surges - data line</b>            |                       |  |
| EN 61000-4-5                                 | line/ground           | 1 kV (U/UTP, SF/UTP)   |
| <b>Conducted disturbances</b>                |                       |  |
| EN 61000-4-6                                 | 150 kHz ... 80 MHz    | 10 V   |
| <b>Immunity</b>                              |                       |  |
| IEC 60068-2-6, test Fc                       | Vibration             | 5 Hz ... 8.4 Hz with<br>3.5 mm amplitude<br>8.4 Hz ... 150 Hz with 1 g |
| IEC 60068-2-27, test Ea                      | Shock                 | 15 g at 11 ms  |

## ■ Network range

### 10/100/1000 Mbit/s twisted pair port

Length of a twisted pair segment max. 100 m (328 ft) (for Cat5e cable)

Table 3: Network range: 10/100/1000 Mbit/s twisted pair port

## ■ Power consumption/power output

| Device name                                  | Max. power consumption | Power output                |
|--|------------------------|-----------------------------|
| BAS20-8TX                                    | 1.4 W                  | 4.8 Btu (IT)/h              |
| BAS20-8TX-HV                                 | 1.4 W                  | 4.8 Btu (IT)/h              |
| BAS22-8TX-HV-55<br>without PoE load          | 2.5 W                  | 8.6 Btu (IT)/h              |
| BAS22-8TX-HV-55<br>with PoE load inc. 55 W   | 11 W + 55 W PoE        | 37.6 Btu (IT)/h + 55 W PoE  |
| BAS22-8TX-HV-110<br>without PoE load         | 2.5 W                  | 8.6 Btu (IT)/h              |
| BAS22-8TX-HV-110<br>with PoE load inc. 110 W | 16 W + 110 W PoE       | 54.6 Btu (IT)/h + 110 W PoE |

Table 4: Power consumption/power output

## ■ Derating

Note the derating values for PoE device variants. The derating values depend on the ambient air temperature of the power supply unit combined with the PoE load and the input voltage.

| Device name      | Ambient temperature                 | Permitted PoE load |
|------------------|-------------------------------------|--------------------|
| BAS22-8TX-HV-55  | up to 45 °C (113 °F)                | 55 W               |
|                  | 45 °C ... 50 °C (113 °F ... 122 °F) | 45 W               |
|                  | 50 °C ... 55 °C (122 °F ... 131 °F) | 37 W               |
|                  | 55 °C ... 60 °C (131 °F ... 140 °F) | 29 W               |
| BAS22-8TX-HV-110 | up to 40 °C (104 °F)                | 110 W              |
|                  | 40 °C ... 45 °C (104 °F ... 113 °F) | 95 W               |
|                  | 45 °C ... 50 °C (113 °F ... 122 °F) | 80 W               |
|                  | 50 °C ... 55 °C (122 °F ... 131 °F) | 65 W               |
|                  | 55 °C ... 60 °C (131 °F ... 140 °F) | 50 W               |

Table 5: Permitted PoE load in relation to ambient air temperature

| Device name     | Input voltage       | Derating of PoE load |
|-----------------|---------------------|----------------------|
| BAS22-8TX-HV-55 | from 100 V AC       | 0 W                  |
|                 | 100 V AC .. 90 V AC | 5 W                  |
|                 | 90 V AC ... 85 V AC | 8 W                  |

Table 6: Additional derating of PoE load in relation to input voltage

| Device name      | Input voltage         | Derating of PoE load |
|------------------|-----------------------|----------------------|
| BAS22-8TX-HV-110 | from 120 V AC         | 0 W                  |
|                  | 120 V AC ... 110 V AC | 10 W                 |
|                  | 110 V AC ... 100 V AC | 17 W                 |
|                  | 100 V AC .. 90 V AC   | 24 W                 |
|                  | 90 V AC ... 85 V AC   | 27 W                 |

Table 6: Additional derating of PoE load in relation to input voltage

## ■ Scope of delivery

| Amount | Article                              |
|--------|--------------------------------------|
| 1 ×    | Device                               |
| 1 ×    | Safety and general information sheet |

## ■ Order number

| Device           | Order number |
|------------------|--------------|
| BAS20-8TX        | 942 307-001  |
| BAS20-8TX-HV     | 942 307-002  |
| BAS22-8TX-HV-55  | 942 307-003  |
| BAS22-8TX-HV-110 | 942 307-004  |

## ■ Underlying technical standards

| Name               |   |
|--------------------|---|
| CSA C22.2 No. 142  | Canadian National Standard(s) – Process Control Equipment – Industrial Products   |
| EN 55032           | Electromagnetic compatibility of multimedia equipment – Emission Requirements   |
| EN 61000-6-2       | Electromagnetic compatibility (EMC) – Part 6-2: Generic standards – Immunity for industrial environments  |
| EN 61000-6-4       | Electromagnetic compatibility (EMC) – Part 6-4: Generic standards – Emitted interference in industrial environments   |
| EN 61000-3-2       | Electromagnetic compatibility (EMC) – part 3-2: Threshold values – threshold values for harmonic currents (device input current $\leq 16$ A per conductor)  |
| EN 61000-3-3       | Electromagnetic compatibility (EMC) – part 3-3: Threshold values – limitation of voltage changes, voltage fluctuations and flickering in public low power supply networks for devices with a rated current $\leq 16$ A per conductor that are not subject to any special connection condition |
| EN 61131-2         | Programmable controllers – Part 2: Equipment requirements and tests   |
| FCC 47 CFR Part 15 | Code of Federal Regulations   |
| UL 61010-1         | Safety requirements for electrical equipment for measurement, control, and laboratory use - Part 1: General requirements  |
| UL 61010-2-201     | Safety requirements for electrical equipment for measurement, control, and laboratory use - Part 2-201: Particular requirements for control equipment   |

*Table 7: List of the technical standards*

The device has an approval based on a specific standard exclusively if the approval indicator appears on the device casing.

The device generally fulfills the technical standards named in their current versions.

# A Further support

## Technical questions

For technical questions, please contact any Hirschmann dealer in your area or Hirschmann directly.

You find the addresses of our partners on the Internet at <http://www.hirschmann.com>.

A list of local telephone numbers and email addresses for technical support directly from Hirschmann is available at <https://hirschmann-support.belden.com>.

This site also includes a free of charge knowledge base and a software download section.

## Customer Innovation Center

The Customer Innovation Center is ahead of its competitors on three counts with its complete range of innovative services:

- ▶ Consulting incorporates comprehensive technical advice, from system evaluation through network planning to project planning.
- ▶ Training offers you an introduction to the basics, product briefing and user training with certification.  
You find the training courses on technology and products currently available at <https://www.belden.com/solutions/customer-innovation-center>.
- ▶ Support ranges from the first installation through the standby service to maintenance concepts.

With the Customer Innovation Center, you decide against making any compromises in any case. Our client-customized package leaves you free to choose the service components you want to use.

Internet:

<https://www.belden.com/solutions/customer-innovation-center>





**HIRSCHMANN**

---

A **BELDEN** BRAND